

DEPARTMENT OF THE ARMY TECHNICAL MANUAL

---

OPERATOR, ORGANIZATIONAL, DIRECT  
SUPPORT, GENERAL SUPPORT, AND DEPOT  
MAINTENANCE MANUAL INCLUDING REPAIR  
PARTS AND SPECIAL TOOL LISTS

MEASURING SET, ENVELOPE DELAY

DISTORTION TS-2669/GCM



HEADQUARTERS, DEPARTMENT OF THE ARMY

APRIL 1969

**WARNING**

**HIGH VOLTAGE**

**is used in this equipment**

**DEATH ON CONTACT**

**MAY RESULT IF SAFETY PRECAUTIONS**

**ARE NOT OBSERVED**

Be careful when working on the ac line connections or the chassis assembly of the equipment. Voltages as high as 230 volts ac may be present. Also, voltages as high as 250 volts may be present. Serious injury or DEATH may result from contact with exposed terminals and connections.

**DON'T TAKE CHANCES!**

**OPERATOR, ORGANIZATIONAL, DIRECT SUPPORT, GENERAL SUPPORT,  
 AND DEPOT MAINTENANCE MANUAL INCLUDING REPAIR PARTS AND  
 SPECIAL TOOL LISTS**

**MEASURING SET, ENVELOPE DELAY DFSTORTION TS-2669/GCM**

		Paragraph	Page
CHAPTER 1.	INTRODUCTION		
Section I.	General		
	Scope .....	1-1	1-1
	Indexes of publications.....	1-2	1-1
	Forms and records.....	1-3	1-1
	II. Description and data		
	Purpose and use .....	1-4	1-1
	New term for cycles per second .....	1-5	1-1
	Technical characteristics.....	1-6	1-2
	Components of TS-2669/GCM.....	1-7	1-2
	Description.....	1-8	1-2
CHAPTER 2.	INSTALLATION		
	Unpacking.....	2-1	2-1
	Checking unpacked equipment .....	2-2	2-1
	Installation of equipment.....	2-3	2-1
CHAPTER 3.	OPERATING INSTRUCTIONS		
	Controls, indicators, and jacks.....	3-1	3-1
	Modes of operation .....	3-2	3-3
	General operating procedures.....	3-3	3-4
	End-to-end operating mode.....	3-4	3-9
	End-to-end with return reference mode .....	3-5	3-10
	Loop mode.....	3-6	3-10
	Operation under unusual conditions .....	3-7	3-10
CHAPTER 4.	ORGANIZATIONAL MAINTENANCE		
Section I.	Preventive maintenance		
	Scope of maintenance .....	4-1	4-1
	Operator's daily preventive maintenance checks and services chart .....	4-2	4-1
	Organizational monthly preventive maintenance checks and services chart.....	4-3	4-2
	Organizational quarterly preventive maintenance checks and services chart ....	4-4	4-2
	II. Troubleshooting, repair, and adjustment		
	General.....	4-5	4-4
	Organizational troubleshooting.....	4-6	4-4
	Repair procedures.....	4-7	4-5
CHAPTER 5.	FUNCTIONING OF EQUIPMENT		
	Transmission distortion .....	5-1	5-1
	Concept of envelope delay.....	5-2	5-1
	Delay measurement.....	5-3	5-1
	Block diagram analysis .....	5-4	5-1
	Description of logic .....	5-5	5-3
	Integrated circuits.....	5-6	5-7
	Circuit descriptions.....	5-7	5-9
CHAPTER 6.	GENERAL SUPPORT MAINTENANCE		
Section I.	General Support Troubleshooting		
	General.....	6-1	6-1
	Localization procedures .....	6-2	6-1
	Isolation procedures.....	6-3	6-1
	II. Repair and testing		
	Removal and replacement procedures.....	6-4	6-2
	Repair procedures.....	6-5	6-2
	Adjustments after repair.....	6-6	6-2

		Paragraph	Page
	Calibration .....	6-7	6-3
	Final test procedures.....	6-8	6-4
CHAPTER	7. DEPOT OVERHAUL STANDARDS		
	Applicability of depot overhaul standards .....	7-1	7-1
	Applicable references.....	7-2	7-1
	Test facilities required.....	7-3	7-1
	Test procedures .....	7-4	7-1
CHAPTER	8. SHIPMENT, LIMITED STORAGE, AND DEMOLITION TO PREVENT ENEMY USE		
	Section I. Shipment and limited storage		
	Disassembly of equipment .....	8-1	8-1
	Repackaging for shipment or limited storage.....	8-2	8-1
	II. Demolition of materiel to prevent enemy use		
	Authority for demolition .....	8-3	8-1
	Methods of destruction.....	8-4	8-1
CHAPTER	9. ILLUSTRATIONS		
	General.....	9-1	9-1
	List of illustrations .....	9-2	9-1
APPENDIX	A. REFERENCES .....		A-1
	B. BASIC ISSUE ITEMS .....		B-1
	C. MAINTENANCE ALLOCATION.....		C-1
	D. ORGANIZATIONAL, DS, GS, AND DEPOT REPAIR PARTS .....		D-1

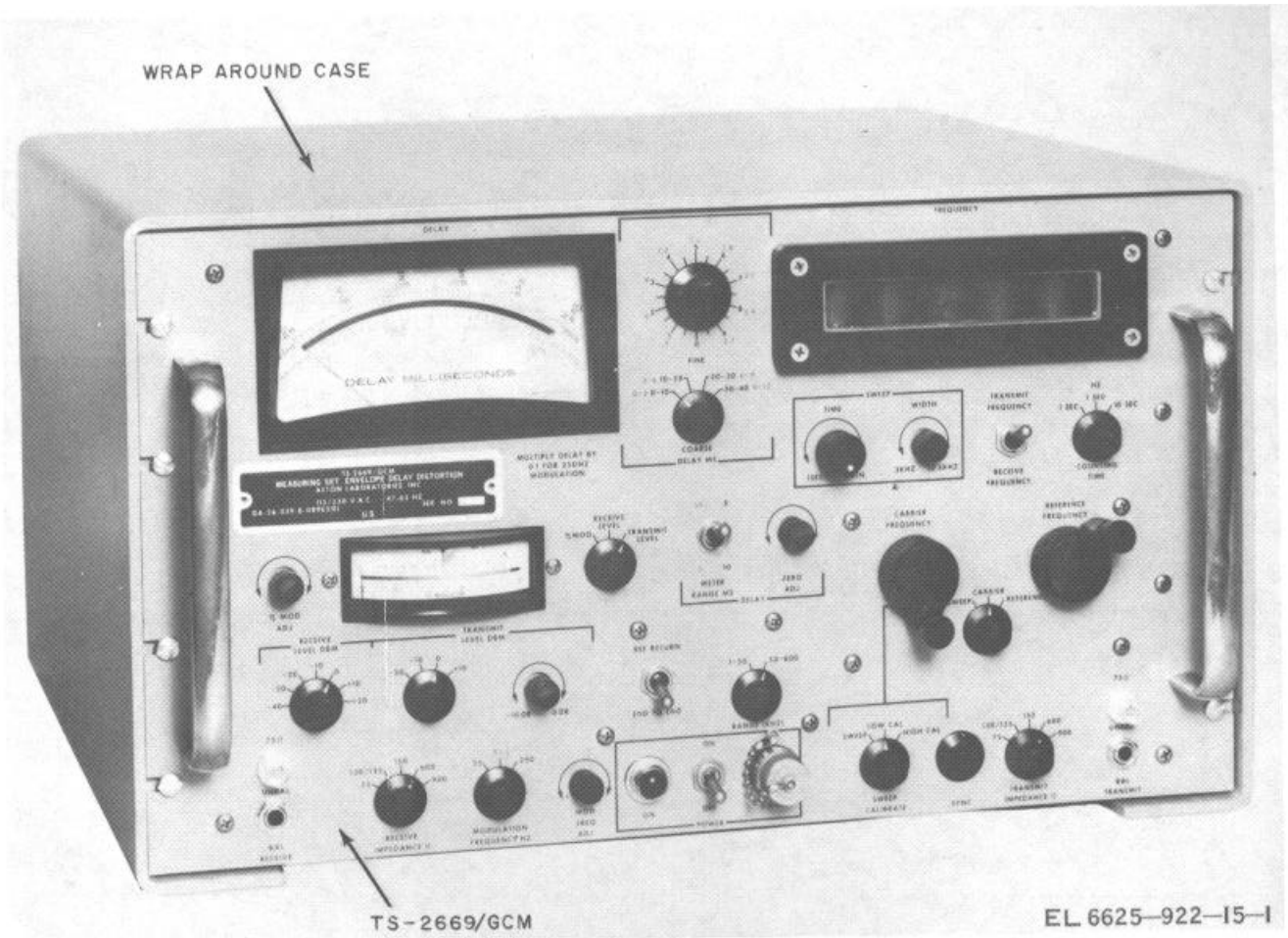

Figure 1-1. Measuring Set, Envelope Delay Distortion TS-2669/GCM.

**CHAPTER 1  
INTRODUCTION**

**Section I. GENERAL**

**1-1. Scope**

a. This manual describes Measuring Set, Envelope Delay Distortion TS-2669/GCM (fig. 1-1), its installation, operation, functioning, repair, and adjustment. It includes instructions for troubleshooting, testing, aligning, and repairing the equipment.

b. A basic issue items list is in appendix B. A maintenance allocation chart is in appendix C. Repair parts are listed in appendix D.

c. Appendixes B, C, and D are current as of 29 January 1969.

**1-2. Indexes of Publications**

a. *DA Pam 310-4.* Refer to DA Pam 310-4 to determine whether there are new editions, changes, or additional publications pertaining to the TS-2669/GCM.

b. *DA Pam 310-7.* Refer to DA Pam 310-7 to determine whether there are modification work orders (MWO's) pertaining to the TS-2669/GCM.

**1-3. Forms and Records**

a. *Reports of Maintenance and Unsatisfactory Equipment.* Use equipment forms and records in accordance with instructions in TM 38-750.

b. *Report of Packaging and Handling Deficiencies.* Fill out and forward DD Form 6 (Report of Packaging and Handling Deficiencies) as prescribed in AR 700-58 (Army), NAVSUP Publication 378 (Navy), AFR 71-4 (Air Force), and MCO P 4610-5 (Marine Corps).

c. *Discrepancy in Shipment Report (DISREP) (SF361).* Fill out and forward Discrepancy in Shipment Report (DISREP) (SF361) as prescribed in AR 55-38 (Army), NAVSUP Pub 459 (Navy), AFM 75-34 (Air Force), and MCO P4610.19 (Marine Corps).

d. *Reporting of Equipment Manual Improvements.* Report of errors, omissions, and recommendations for improving this equipment manual by the individual user is encouraged. Reports should be submitted on DA Form 2028 (Recommended Changes to DA Publications) and forwarded direct to the Commanding General, U.S. Army Electronics Command, ATTN: AMSEL-ME-NMP-AD, Fort Monmouth, N.J. 07703.

**Section II. DESCRIPTION AND DATA**

**1-4. Purpose and Use**

The TS-2669/GCM is used to test and measure envelope delay characteristics of voice frequency and data communication networks. It is capable of providing accurate delay and attenuation measurements in the frequency range of 100 Hertz (Hz) to 552 kilohertz (kHz). The TS-2669/ GCM was designed specifically for use with standard telephone lines, group equipment, and

supergroup equipment. It can also be used with active and passive networks, filters, and equalizers.

**1-5. New Term for Cycles Per Second**

The National Bureau of Standards has officially adopted the term HERTZ for cycles per second. The following chart provides the common equivalents.

Unit/Quantity	Old term	Old abbrev	New term	New abbrev
Frequency 10 <sup>-3</sup> cycles per second	Cycles per second Millicycles per second	cps mc	Hertz Millihertz	Hz mHz

Unit/quantity	Old term	Old abbrev	New term	New abbrev
10 <sup>3</sup> cycles per second	Kilocycles per second	Kc	Kilohertz	kHz
10 <sup>6</sup> cycles per second	Megacycles per second	Mc	Megahertz	MHz
10 <sup>9</sup> cycles per second	Gigacycles per second	Gc	Gigahertz	GHz

**1-6. Technical Characteristics**

Carrier and reference frequencies:

Range..... 100 Hz to 552 kHz.  
 Distortion ..... Less than -40 db.  
 Drift (10 minutes)..... 10 Hz to 50 kHz; ±5 Hz or ±0.05 percent whichever is greater.  
 50 kHz to 552 kHz; ±50 Hz or ±0.05 percent whichever is greater.

Modulation:

Frequencies..... 25 Hz, 83 1/3 Hz, 250 Hz.  
 Drift ..... Less than 2 x 10<sup>-8</sup> in 5 minutes; less than 1 x 10<sup>-6</sup> per day.  
 Adjustment..... ±0.005 percent.

Receiver input:

Level..... -45 dbm to +20 dbm.  
 Impedance..... 900, 600, 150, 130/135 ohms ±10 percent, balance greater than 40 db; 75ohms ±10 percent, unbalanced.

Transmitter output:

Level..... -20 dbm to +10 dbm, continuously adjustable.  
 Impedance..... 900, 600, 150, 130/135 ohms ± 10 percent, balance greater than 40 db; 75ohms ± 10 percent, unbalanced.

Delay indication:

25 Hz      83-1/3 Hz      250 Hz  
*mod freq*

Range..... 0-40 ms    0-12 ms    0-4 ms  
 Accuracy..... ±25 µs    ±10 µs    ±2 µs

Frequency counter:

Readout..... 5 digits, in-line.  
 Accuracy..... 50 x 10<sup>-6</sup>, ±1 digit.  
 Range..... .0 to 1 MHz.

Level meter:

Accuracy..... ±0.3 db.  
 Level range..... 10 db on meter, -40 to +20 db with attenuator.  
 Frequency range..... 0 to 600 kHz.

Sweep mode:

Speed..... 1 sweep/sec. to 0.5 sweep/minute.  
 Bandwidth..... 300 Hz to 12.5 kHz (0.1 to 50 kHz); 3 kHz to 125 kHz (50 to 552 kHz).

Operating modes..... End-to-end; End-to-end with return reference; and loop back.

Analog outputs ..... Analog delay with marker frequency insertion capability; analog frequency (logarithmic); and analog amplitude.

Operating temperature range. Is from +32° F to +120° F.  
 Primary power..... 115 or 230 vac +10 percent, 47 to 63 Hz, single phase.

**1-7. Components of TS-2669/GCM**

The components and running spares of the TS-2669/GCM are listed in the basic tissue items list (appx B).

**1-8. Description**

a. The TS-2669/GCM (fig. 1-1) consists of a chassis (17-1/8 inches wide and 15 inches deep) with a front panel (19 inches wide and 10 3/4 inches high). It weighs approximately 45 pounds. The unit is suitable for mounting in a standard 19-inch equipment rack. Two handles are mounted on the front panel to protect the front panel controls and also to aid in removing the chassis assembly from an enclosure. The unit is supplied in a wrap-around case.

b. Input and output signal wires are brought to terminal boards at the rear of the chassis. Power connection is provided by a 6-foot power cord from the rear of the unit. This is normally wired for 115-volt alternating current (ac).

c. Operational controls, power switch, and primary power fuse are located on the front panel. Test points for maintenance and operational testing are located on printed circuit boards within the enclosed chassis.

## CHAPTER 2

### INSTALLATION

---

#### 2-1. Unpacking

The TS-2669/GCM is packed in a carton that is approximately 24 by 22 inches and weighs 55 pounds (fig. 2-1). Unpack the equipment as follows:

- a. Cut paper tape and top of box and open.
- b. Open box and remove four Hardigg corner cushions that support inner box.
- c. Lift inner box from outer box.
- d. Cut tape on inner box cover and open.
- e. Remove plywood brace by sliding it straight up.
- f. Lift TS-2669/GCM out of inner box.

#### 2-2. Checking Unpacked Equipment

a. Inspect the equipment for damage incurred during shipment. If the equipment has been damaged, report the damage on DD Form 6 (para 1-3b).

b. See that the equipment is complete as listed on the packing slip. If a packing slip is not available, check the equipment against the basic issue items list (app B).

**Note. Shortage of a minor assembly or part that does not affect proper functioning of the equipment should not prevent use of the equipment.**

c. If the equipment has been used or reconditioned, see whether it has been changed by a modification work order (MWO). If the equipment has been modified, the MWO number will appear on the front panel near the nomenclature plate. Check to see whether the MWO number (if any) and appropriate notations concerning the modification have been entered in the equipment manual.

**Note. Current MWO's applicable to the equipment are listed in DA Pam 310-7.**

#### 2-3. Installation of Equipment

- a. Remove the chassis assembly from the case.
- b. Remove the top cover by unscrewing the holding screws.
- c. Check the internal power supply connections (fig. 2-2), and make sure the connections are set for the proper primary power, either 115- or 230volt vac operation.
- d. Make sure that all printed circuit modules are seated firmly in their respective connectors, so that correct electrical contact is made.
- e. Replace top cover, and secure with the screws provided.
- f. Operate front panel POWER switch to OFF.
- g. Check to see that a fuse of the proper rating (1 ampere) is installed in the fuseholder.

**Warning: Make sure the power cord is disconnected at the *primary power outlet*, and that the POWER switch on the TS-2669/GCM is in the OFF position before touching or changing the internal power supply connection.**

**Caution: The proper internal power supply connection (fig. 2-2) must be made, depending on the voltage of the primary power.**

h. Remove the bottom cover of the TS-2669/ GCM and check to see that the proper internal power supply connections are made for either 115- or 230-volt ac operation on terminal board TB3 (fig. 2-2 and 9-36).

**Note. A power cord is supplied at the rear of the TS-2669/GCM.**

i. If desired, install the TS-2669/GCM in a 19-inch equipment rack; otherwise, replace the unit in its carrying case.



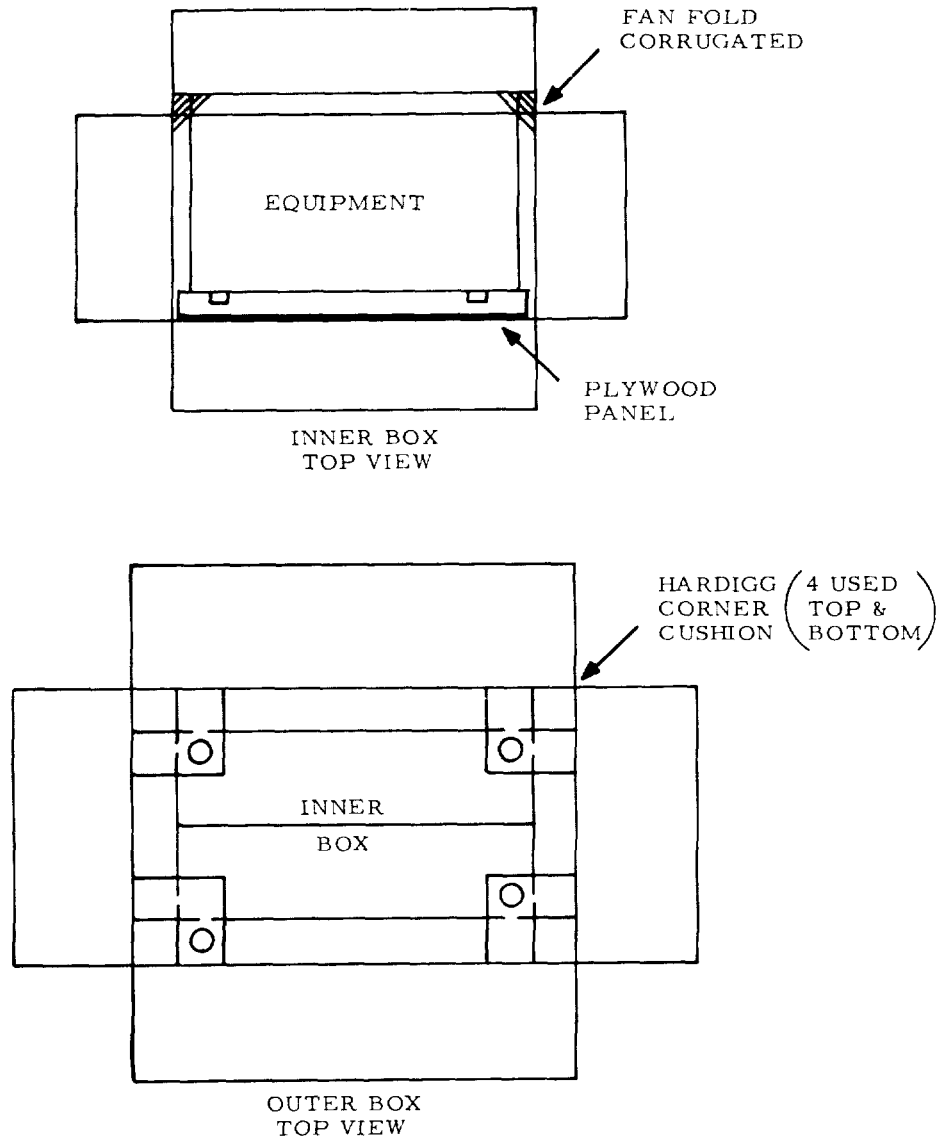

EL 6625-922-15-2

Figure 2-1. Packaging diagram

a. Connection for 115 VAC operation.

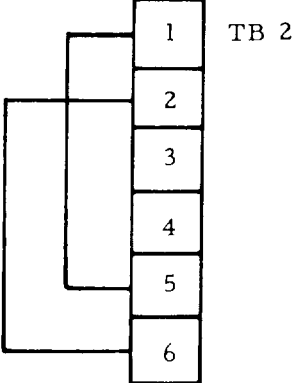

b. Connection for 230 VAC operation.

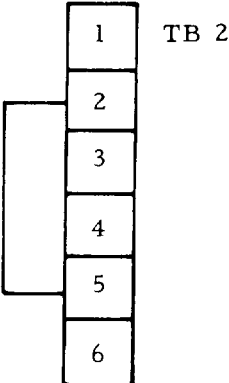

EL 6625-922-15-3

Figure 2-2. Internal power supply connections.

## CHAPTER 3

### OPERATING INSTRUCTIONS

---

#### 3-1. Controls, Indicators, and Jacks (fig. 3-1)

Control, Indicator, or jack	Function
POWER (2-position toggle) switch POWER ON indicator 1 AMP fuse RECEIVE LEVEL DBM (7-position rotary) switch	Controls primary power to TS-2669/GCM. Lights to indicate ac power is on. Protects ac input line. Attenuates input signal fed to input amplifier. Indicated number corresponds to level in dbm. Minimum attenuation is at setting of -40.
TRANSMIT LEVEL DBM (4-position rotary) switch	Controls output signal level. Indicated number corresponds to power level in dbm. Maximum output level is at setting of +10.
TRANSMIT LEVEL DBM control	Provides fine adjust for output signal level. Between 0 and 10 db can be added to level set by 4-position TRANSMIT LEVEL DBM switch.
BAL RECEIVE jack	Accepts telephone-type plug for application of balanced input signal, terminated in impedance between 130 and 900 ohms.
75 $\Omega$ UNBAL RECEIVE jack	Accepts BNC connector for application of unbalanced input signal, terminated in impedance of 75 ohms.
RECEIVER IMPEDANCE $\Omega$ (5-position rotary) switch	Selects terminating impedance for input signal. With 75 (ohms) setting, 75 $\Omega$ UNBAL RECEIVE jack must be used. With other 4 settings, 130 to 900 (ohms), BAL RECEIVE jack must be used.
MODULATION FREQUENCY HZ (3-position rotary) switch	Selects modulating frequency in Hz. Note that 83 1/3 number is in red; this means that when switch is in this position, red numbers on instrument are to be used, instead of black numbers. Black numbers are used with modulating frequencies of 25 or 250 Hz.
MOD FREQ ADJ control	Adjustable control for varying modulating frequency in end-to-end mode of operation. Frequency can be changed up to $\pm 50$ parts per million (PM).
% MOD ADJ control	Adjust control for varying percentage of modulation between 0 and 50 percent. This should always be set for a nominal 50 percent modulation.
dbm/% MODULATION meter	Measures percentage of modulation or signal level in dbm, as selected by % MOD/RECEIVE LEVEL/TRANSMIT LEVEL switch. To determine correct signal level, meter indication must be added algebraically to RECEIVE LEVEL DBM or TRANSMIT LEVEL DBM switch setting number. If meter reads -6, and RECEIVE LEVEL DBM or TRANSMIT LEVEL DBM switch is set to -10, correct level is -16 dbm. If either switch was set to +10, then correct level would be +4 dbm. TRANSMIT LEVEL DBM and RECEIVE LEVEL DBM switches should be set so that dbm/% MODULATION meter reading is always between 0 and -10 dbm.
% MOD-RECEIVE LEVEL-TRANSMIT LEVEL (3-position rotary) switch	Selects which parameter dbm/% MODULATION meter will measure.

**Control, indicator, or jack**  
 DELAY METER RANGE MS (2-position toggle) switch

**Function**  
 Selects either a coarse or a fine delay reading.

<b>Sw pos</b>	<b>Function</b>
3-10	DELAY meter indicates coarse delay. For a modulating frequency of 25 Hz, DELAY meter indicates within a range of 10 milliseconds; 83-1/3 Hz, a range of 3 ms; 250 Hz a range of 1 ms.
15-15	DELAY meter indicates fine delay. For modulating frequency of 25 Hz, there is a range of 0.5 MS (500 us); 83-1/3 Hz, 0.15 MS (150 us); 250 Hz, 0.05 ms (50 us).

COARSE DELAY MS (4-position rotary) switch

Selects the particular coarse range for DELAY meter reading.

FINE DELAY MS (20-position rotary) switch

Selects the particular fine range for DELAY meter reading.

DELAY meter

Indicates envelope delay of an input signal, within a time range in milliseconds, as determined by settings of the 3 previously mentioned switches, and the selected modulating frequency. Red numbers are used with a modulating frequency of 83-1/3 Hz. When DELAY METER RANGE MS switch is in 3-10 position, correct delay is determined by adding algebraically the number setting of COARSE DELAY MS switch and DELAY meter indication. When DELAY METER RANGE MS switch is in .15-.5 position correct delay is determined by adding algebraically the number setting of COARSE DELAY MS switch, the number setting of FINE DELAY MS switch, and the DELAY meter indication.

DELAY ZERO ADJ control

Adjusts signal delay within instrument, so that relative delay of a reference signal can be read as zero, or other convenient number.

REF RETURN-END TO END (2-position toggle) switch

Selects mode of operation.

RANGE (KHZ) (2-position rotary) switch

Selects frequency range for carrier and reference frequency.

CARRIER FREQUENCY control

Adjust output signal carrier frequency.

REFERENCE FREQUENCY control

Adjust reference carrier frequency.

SWEEP-CARRIER-REFERENCE (3-position rotary) switch

<b>Sw pos</b>	<b>Function</b>
REFERENCE	Frequency of transmitted signal is determined by REFERENCE FREQUENCY control.
CARRIER	Frequency of transmitted signal is determined by CARRIER FREQUENCY control.
SWEEP	Frequency of transmitted signal is determined by CARRIER FREQUENCY control, plus SWEEP controls. In this position, SWEEP CALIBRATE switch is operative.

Control, Indicator, or jack	Sw pos	Function
SWEEP CALIBRATE (3-position rotary) switch	SWEEP	Frequency of output signal is swept, with a minimum frequency set by CARRIER FREQUENCY control, sweep bandwidth set by SWEEP WIDTH control, and sweep speed set by SWEEP TIME control.
	LOW CAL	Output frequency is approximately lowest frequency in sweep, with all other controls remaining fixed.
	HIGH CAL	Output frequency is approximately highest frequency in sweep, with all other controls remaining fixed.
SWEEP TIME control		Adjusts time it takes for output frequency to sweep between lowest and highest frequencies, and also to sweep down again from highest to lowest.
SWEEP WIDTH control		Adjust bandwidth of sweep frequency. CARRIER FREQUENCY controls set lowest frequency, and SWEEP WIDTH control effectively sets highest frequency.
TRANSMIT FREQUENCY-RECEIVE FREQUENCY (2-position toggle) switch		Selects output transmitted or input received signal frequency to be measured and indicated on FREQUENCY display.
COUNTING TIME (3-position rotary) switch		Selects time interval for counting pulses for frequency measurement. Counts frequency in Hz in 1 SEC position.
FREQUENCY display		Corresponds to frequency by indicating the number of pulses within COUNTING TIME. The number is displayed for about 1 second. When the COUNTING TIME switch is in the 1 SEC position, the FREQUENCY display indicates the frequency directly in Hz. When in the .1 SEC position, the least significant digit represents 10 Hz; when in the 10 SEC position, it represents 0.1 Hz.
BAL TRANSMIT jack		Accepts telephone-type plug for sending balanced output signal, with output impedance between 130 and 900 ohms.
75 Ω UNBAL TRANSMIT jack		Accepts BNC connector for sending an unbalanced output signal, with an output impedance of 75 ohms.
TRANSMIT IMPEDANCE (5-position rotary) switch		Selects output impedance of the transmitted signal. With 75 (ohm) setting, 75 Ω UNBAL TRANSMIT jack must be used. With other 4 settings, 130 to 900 (ohms), BAL TRANSMIT jack must be used.
SYNC pushbutton		Provides a means of synchronizing the effective phase of the local receiver modulating frequency with the transmitter modulating frequency in end-to-end measurements, so that readings can be made near zero (0) envelope delay.

**Note.** Figure 3-2 shows the signal connections on the rear panel connectors.

### 3-2. Modes of Operation

a. *End-to-End.* An end-to-end measurement is made over a single transmission line (fig. 3-3), because no other lines are available for use as a return reference. A modulated carrier produced by the transmitting TS-2669/GCM is sent down the line. At the receiving end of the line, a reference signal produced by a receiving TS-2669/GCM is synchronized with the

modulation frequency of the received carrier signal. This is usually done with a transmitted carrier frequency in the range of anticipated minimum transmission delay of the line under test. The carrier frequency of the transmitting TS-2669/GCM is then varied over the pass band of the transmission line while noting the variation in line output level and delay time at the receiving TS-2669/GCM.

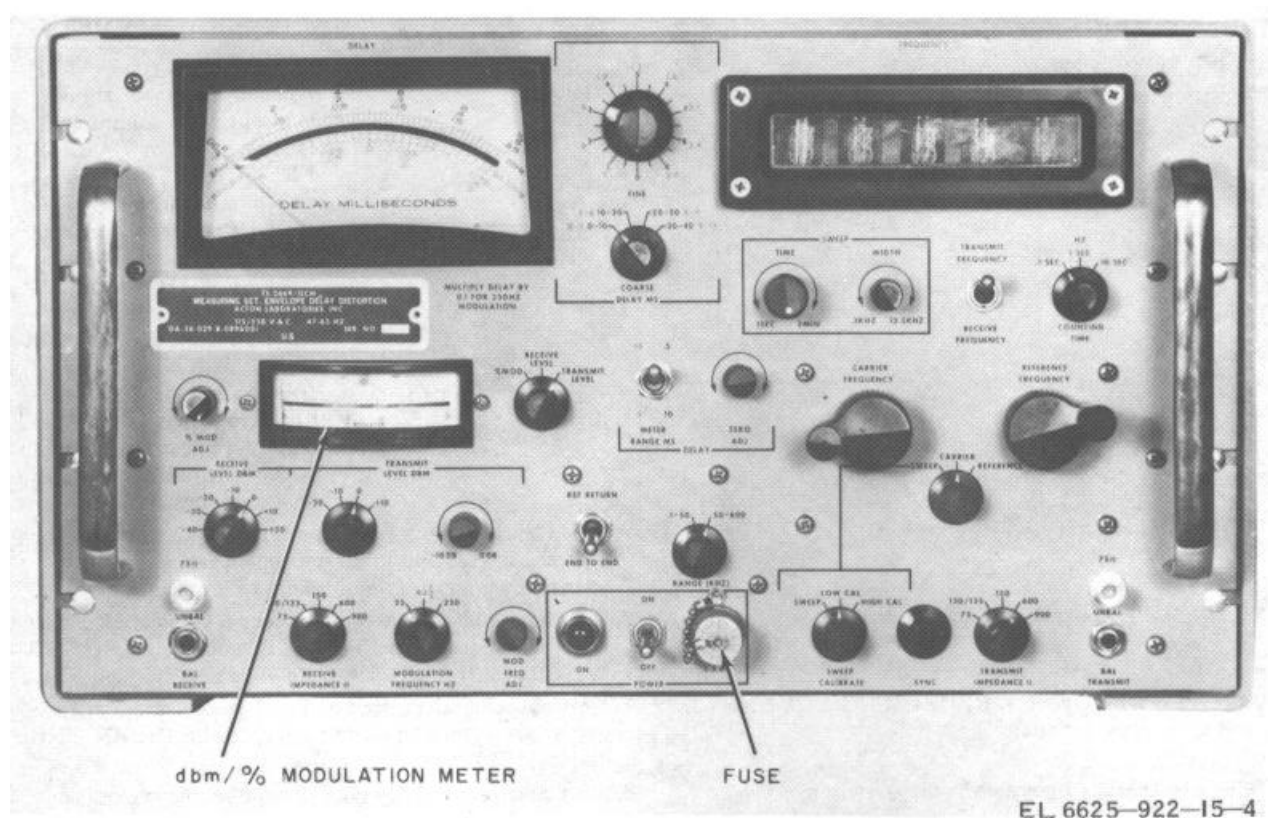

Figure 3-1. Operator's controls and indicators.

b. *End-to-End with Return Reference.* When two transmission lines are available, one of the lines can be used to return the time-delay information of the line under test back to the transmitting point (fig. 3-4). The modulated carrier produced by the transmitting TS-2669/GCM is sent down the test line. At the end, the signal is demodulated by a receiving TS-2669/GCM and the modulation component is remodulated onto a fixed frequency reference carrier signal produced by the receiving TS-2669/GCM. This reference signal is sent back to the receiver section of the transmitting TS-2669/GCM. The signal received at the transmitting TS-2669/GCM contains phase shifts corresponding to the delay of the measured line plus the fixed delay introduced by the auxiliary channel; therefore, relative delay measurements can be made on the measured line section. With this system, the required delay measurements can be made from the transmitting TS-2669/GCM. However, the amplitude characteristic of the line under measurement must be made at the receiving TS-2669/GCM.

c. *Loop Mode.* In the loop method (fig. 3-5), the line to be tested is connected at the far end to a second line returning the signal to the TS-2669/GCM. Transmission and reception are conducted at the same location, and delay and amplitude measurements can be made easily. In the loop mode, delay of the forward and return paths cannot be separated; therefore, it is assumed that the forward and return path characteristics are equal.

### 3-3. General Operating Procedures

a. The TS-2669/GCM must be connected to a 115- or 230- volt ac power source by the power cable at the rear of the unit. Before doing this, check to make sure the unit is internally strapped for the proper line voltage (fig. 2-2).

**Caution: The TS-2669/GCM must be grounded by the ground terminal on the UP-121/M connector on the power cable or a shock hazard may result.**

b. Operate the POWER switch to ON. Check to see that the POWER ON indicator is lighted. Allow a 1-minute warmup period.

c. Operate the REF RETURN-END TO END switch to END TO END.

d. Operate the % MOD-RECEIVE LEVEL-TRANSMIT LEVEL switch to % MOD. Operate the MODULATION FREQUENCY HZ switch to the desired modulating frequency (25, 83-1/3, or 250 Hz). Note that the modulating frequency to be used must be one-quarter of the lowest carrier frequency to be used or less, for example:

Mod freq	Lowest carrier freq to be used
25 Hz	100 Hz
83 1/3 Hz	334 Hz
250 Hz	1,000 Hz

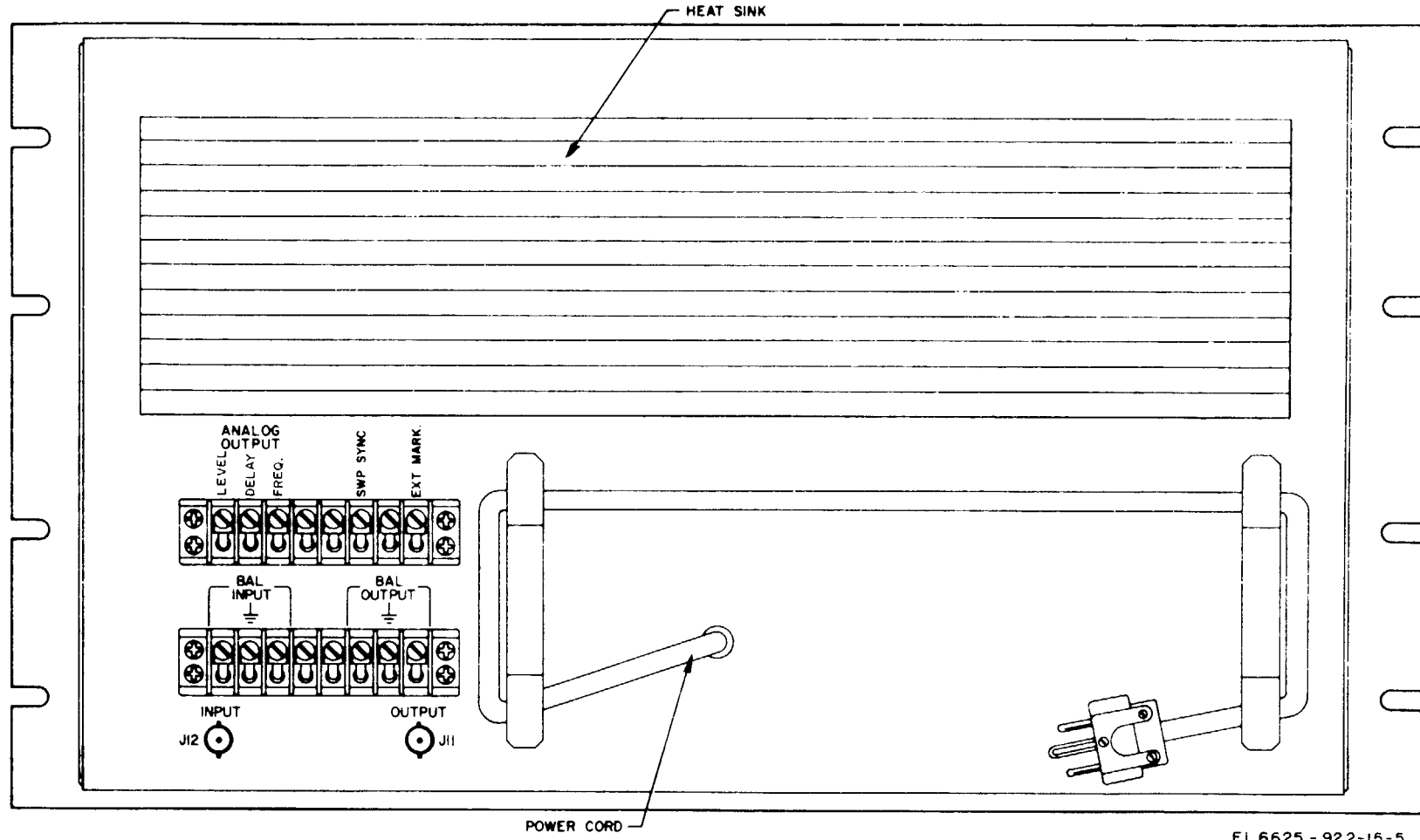

EL 6625 - 922-15-5.

Figure 3-2. Rear panel, location of connectors.

(1) For operation in the voice-frequency band (300 Hz to 3,400 Hz), use the 25-Hz modulating frequency.

(2) Operate the % MOD ADJ control to obtain a reading of 45 to 50 percent on the dbm/% MODULATION meter. Whenever the modulating frequency is changed, always adjust the % MOD ADJ control to maintain the 45- to 50 percent modulation level.

e. Operate the MOD FREQ ADJ control fully counterclockwise (ccw) and then 5 turns clockwise (cw)

f. Operate the TRANSMIT FREQUENCY-RECEIVE FREQUENCY switch to TRANSMIT FREQUENCY.

g. Operate the SWEEP-CARRIER-REFERENCE switch to CARRIER.

h. Operate the TRANSMIT LEVEL DBM control fully cw.

i. Operate the COUNTING TIME switch to 1 SEC.

j. Operate the % MOD-RECEIVE LEVEL-TRANSMIT LEVEL switch to TRANSMIT LEVEL.

k. Operate the TRANSMIT IMPEDANCE  $\Omega$  switch to the position required to match the impedance (75 ohm, 130/135, 150, 600, or 900) of the transmission line to be measured. The 75-ohm position provides an

output signal only at the 75  $\Omega$  UNBAL TRANSMIT jack and is usable only in the 50- to 552-kHz frequency range. The 130/135-, 150-, 600-, and 900-ohm positions provide an output only at the BAL TRANSMIT jack and are usable only in the 0.1 to 110-kHz frequency range.

**Caution: Do not connect the UNBAL TRANSMIT or BAL TRANSMIT jacks directly to a line having a dc potential. Use external coupling capacitors for isolation.**

l. The output signal at either TRANSMIT jack cannot be monitored for amplitude by the dbm/% MODULATION meter, which reads actual power in dbm into the transmission line load, relative to one milliwatt. The impedance switching arrangement automatically corrects the signal line voltage so that only power is read on the dbm/% MODULATION meter. The frequency of the transmit signal may be monitored by the FREQUENCY display in Hz. The transmit signal level is read by adding the db reading on the TRANSMIT LEVEL DBM switch to the indication on the

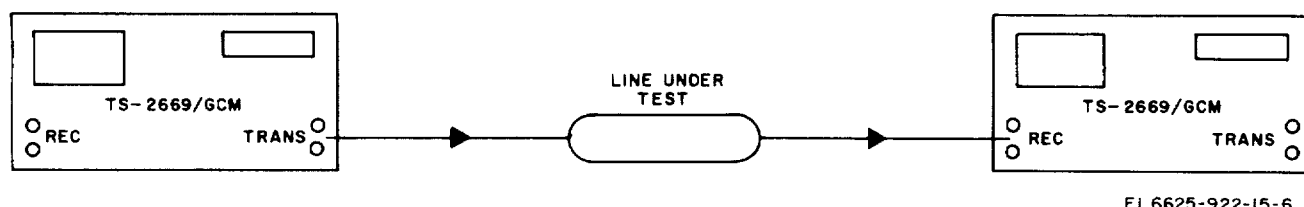

Figure 3-3. Connections for end-to-end mode.

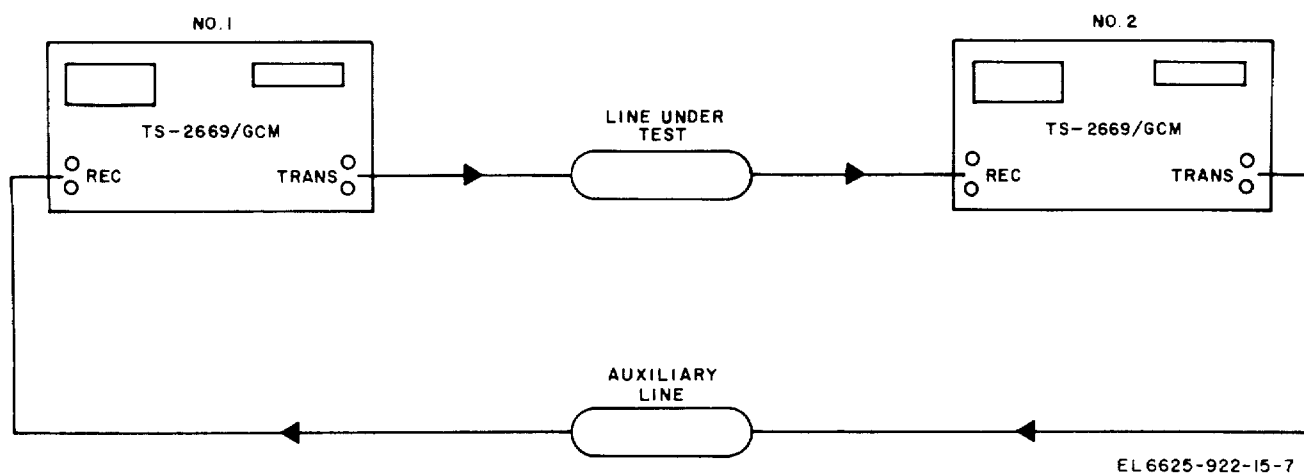

Figure 3-4. Connections for end-to-end with return reference.



dbm/1% MODULATION meter, for example:

TRANSMIT LEVEL DBM switch	dbm/% MODULATION meter	Output level
-10	-3 DB	-13 DBM
0	0 DB	0 DBM
+10	-5 DB	+ 5 DBM

m. Operate the RANGE (KHZ) switch to the desired frequency range. To operate between 100 Hz and 50 kHz, use the .1-50 position. If operating in the 50- to 552-kHz range, use the 50-600 position.

n. The CARRIER FREQUENCY control is used to vary the transmit signal within the desired range. This control can vary the signal out of the ranges, but operation should be maintained within the designated ranges. The reference frequency can also be used by operating the SWEEP - CARRIER - REFERENCE switch to REFERENCE and using the REFERENCE FREQUENCY control as described for the CARRIER FREQUENCY control. The reference frequency will also be transmitted at the TRANSMIT jacks. It is used as a fixed reference frequency in the band of operation which can always be returned to in order to check for drift in measurements without having to crank the CARRIER FREQUENCY control all the way back. The CARRIER FREQUENCY control is normally used to make all measurements and the REFERENCE FREQUENCY control is left at a fixed frequency.

o. Operate the TS-2669/GCM in the sweep mode for the signal frequency as follows:

- (1) Operate SWEEP-CARRIER-REFERENCE switch to SWEEP.
- (2) Operate RANGE (KHZ) switch to desired frequency range of operation.

(3) Operate SWEEP CALIBRATE switch to LOW CAL.

(4) Operate the CARRIER FREQUENCY control to the desired low end frequency, monitored on the FREQUENCY display, of the frequency band to be swept.

(5) Operate the SWEEP CALIBRATE switch to HIGH CAL.

(6) Operate the SWEEP WIDTH control to the desired high end frequency, monitored on the FREQUENCY display, of the frequency band to be swept.

(7) Operate the SWEEP CALIBRATE switch to SWEEP. The output signal will automatically sweep between the frequency limits set up at LOW CAL and HIGH CAL positions. The rate of the frequency sweep is adjustable by the SWEEP TIME control.

p. Connect the input signal to either RECEIVE jack of the TS-2669/GCM. This is the signal which is obtained from the opposite end of the transmission path to which the transmit signal is connected. The 75 Ω UNBAL RECEIVE jack is used only for 75-ohm impedances in the frequency range from 50 kHz to 552 kHz. The BAL RECEIVE jack is used for 130/135-, 150-, 600-, and 900-ohm impedances in the frequency range from 0.1 kHz to 110 kHz.

**Caution: Do not connect the BAL RECEIVE jack directly to a line having a dc potential. Use external coupling capacitors for these connections.**

q. Operate the RECEIVE IMPEDANCE Ω switch to the proper position to match the transmission line being used.

r. Operate the % MOD-RECEIVE LEVEL-TRANSMIT LEVEL switch to RECEIVE LEVEL. Monitor the level at the RECEIVE jacks on the dbm/% MODULATION meter.

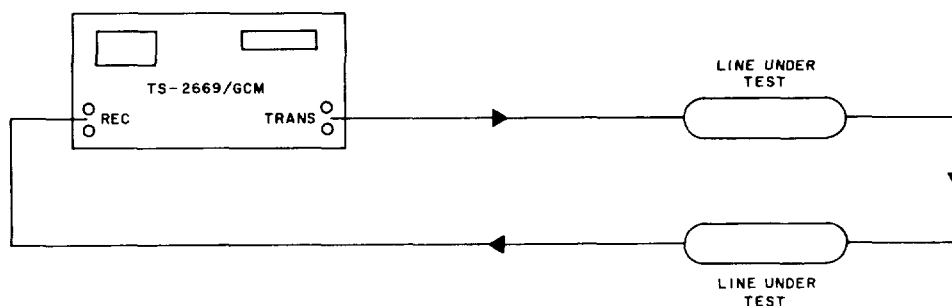

EL 6625-922-15-8

Figure 3-5. Connection for loop mode.

s. Operate the RECEIVE LEVEL DBM control cw to the position at which the dbm/% MODULATION meter indicates between 0 DBM and -10 DBM. The receive signal may now be measured by adding the RECEIVE LEVEL DBM switch db setting to the indication on the dbm/% MODULATION meter, for example:

RECEIVE LEVEL DBM switch	dbm/% MODULATION meter	Receive level
-20 db	-3 db	-23 dbm
0 db	0 db	0 dbm
+20 db	-5 db	+15 dbm
-10 db	-5 db	-15 dbm.

t. Read the DELAY meter as follows:

(1) The face of the DELAY meter has six scales, three of which (black) correspond to 25 Hz and 250 Hz modulation frequency (divide markings by 10 for 250 Hz), and three of which (red) correspond to 83-1/3 Hz. The black scales are 0 to 0.5 millisecond, 0 to 10 milliseconds, and -0.25 to +0.25 millisecond (used for reference only). The red scales are 0 to 0.15 millisecond, 0 to 3 milliseconds, and -0.075 to +0.075 millisecond (used for reference only).

(2) The FINE DELAY MS switch has 20 positions with delay increments of 0.5 millisecond

(black) from 0 to 9.5 milliseconds. The black markings are used for 25 Hz and 250 Hz modulating frequencies (for 250 Hz divide black markings by 10). The red markings in .15-millisecond increments, from 0 to 3 milliseconds, are used for 83-1/3 Hz.

(3) The COARSE DELAY MS switch has four positions. The black markings in increments of 10 milliseconds, from 0 to 40 milliseconds, are used for 25 Hz and 250 Hz modulating frequencies (for 250 Hz divide markings by 10). The red markings in increments of 3 milliseconds, from 0 to 12 milliseconds, are used for the 83-1/3 Hz.

(4) When the DELAY METER RANGE MS switch is in the .15-.5 position, the delay reading is obtained by using the 0 to .5 (black) or 0 to .15 (red) scale on the DELAY meter, the FINE DELAY MS switch, and the COARSE DELAY MS switch. The readings on the DELAY meter, the FINE DELAY MS switch setting, and the COARSE DELAY MS switch setting are added together to give the total delay.

(5) If the DELAY METER RANGE MS switch is in the 3-10 position, the delay reading is obtained by using the 0-10 (black) or 0 to 3 (red) scale on the DELAY meter, and only the COARSE DELAY MS switch. The readings on the DELAY meter and the COARSE DELAY MS switch setting are added together to give the total delay. Examples of delay readings are as follows:

Mod freq	Scale color	DELAY METER RANGE MS	COARSE DELAY MS	FINE DELAY MS	DELAY meter	Correct delay
25	Black	3 - 10 ms	10 - 20 ms	--	4.5 ms	14.5 ms
25	Black	.15 - .5	10 - 20	3.5	0.28	13.78
83-1/3	Red	.15 - .5	6 - 9	1.5	0.23	7.73
250	Black	3 - 10	20 - 30	--	3.5	2.35

(6) When a signal of unknown delay is connected between the TRANSMIT jack and RECEIVE jack, the following general procedure is employed in reading the delay. The desired signal frequency is set on the transmitter by the CARRIER FREQUENCY control. The RECEIVE LEVEL DBM switch is operated to obtain a receive level on the dbm/% MODULATION meter between 0 DB and -10 DB. Assuming that 25 Hz modulation is used, the approximate delay is read with the DELAY METER RANGE MS switch in the 3-10 ms position by operating the COARSE DELAY MS switch until an on-scale DELAY meter reading is obtained. This approximate value of delay is read on the black 0 to 10 ms scale of the DELAY meter. The total delay is the setting of the COARSE DELAY MS switch plus the DELAY meter reading. In general, this 3-8 coarse delay

reading is used to provide a general profile of delay versus frequency. Operate the DELAY METER RANGE MS switch to the .15.5 position. Operate the FINE DELAY MS switch until an on-scale reading is obtained on the DELAY meter. The total delay may now be precisely read by adding the DELAY meter reading (black 0 to .5 ms scale) to the FINE DELAY MS switch setting plus the COARSE DELAY MS switch setting. If 250 Hz modulation is used, all black DELAY meter, COARSE DELAY MS switch, FINE DELAY MS switch, and DELAY METER RANGE MS switch markings are divided by 10. If 83-1/3 Hz modulation is used, the red markings are used. The TS-2669/GCM provides unambiguous delay readings up to 40 milliseconds for 25 Hz modulation, 12 milliseconds for 83-1/3 Hz

modulation, and 4 milliseconds for 250 Hz modulation.

### 3-4. End-to-End Operating Mode

a. To perform a transmission line delay measurement using the end-to-end mode, use a TS-2669/GCM at the input to the line and a separate TS-2669/GCM at the output of the line (fig. 3-3). Allow a 30-minute warmup period for both units. A modulated carrier produced by the transmitting TS-2669/GCM is sent down the line. At the receiving end of the line, a reference signal generated by the receiving TS-2669/GCM is adjusted to synchronize with the modulating frequency of the received signal. This is usually done with a transmitted carrier signal in the frequency range of anticipated minimum delay of the line under test. The carrier frequency of the transmitting TS-2669/GCM is then varied over the pass band of the transmission system while noting the variation in line output level and delay at the receiving TS-2669/GCM.

b. Using the measurement setup of figure 3-3, operate the controls and switches on the *transmitting* TS-2669/GCM as follows:

- (1) POWER switch to ON.
- (2) REF RETURN-END TO END switch to END TO END.
- (3) % MOD - RECEIVE LEVEL-TRANSMIT LEVEL switch to % MOD.
- (4) MODULATION FREQUENCY HZ switch to 250.
- (5) Adjust % MOD ADJ control to obtain 45- to 50-percent reading on dbm/% MODULATION meter.
- (6) % MOD - RECEIVE LEVEL-TRANSMIT LEVEL switch to TRANSMIT LEVEL.
- (7) TRANSMIT FREQUENCY-RECEIVE FREQUENCY switch to TRANSMIT FREQUENCY.
- (8) SWEEP - CARRIER - REFERENCE switch to REFERENCE.
- (9) TRANSMIT LEVEL DBM switch to proper output signal range.
- (10) TRANSMIT LEVEL DBM control to exact output level.
- (11) COUNTING TIME switch to 1 SEC.
- (12) TRANSMIT IMPEDANCE  $\Omega$  switch to proper impedance.
- (13) MOD FREQ ADJ control fully ccw and then 5 turns cw.
- (14) REFERENCE FREQUENCY control to middle of measurement band (at least 1 kHz).

c. Operate the controls and switches on the receiving TS-2669/GCM as follows:

- (1) RECEIVE IMPEDANCE  $\Omega$  switch to proper impedance.
- (2) % MOD-RECEIVE LEVEL-TRANSMIT LEVEL switch to RECEIVE LEVEL.
- (3) RECEIVE LEVEL DBM switch to obtain a reading on the dbm/% MODULATION meter between 0 DB and -10 DB.
- (4) MODULATION FREQUENCY HZ switch to 250.
- (5) DELAY AMETER RANGE MS switch to .15-.5.
- (6) COARSE DELAY MS and FINE DELAY MIS switches to obtain an onscale reading on the DELAY meter.
- (7) The DELAY meter indication will oscillate backs and forth slowly. Adjust the MOD FREQ ADJ control slowly until the DELAY meter indication is stable. Now both the transmitting and receiving TS-2669/GCM's are synchronized.
- (8) Momentarily depress the SYNC pushbutton. The DELAY meter indication will now deflect to the extreme left of scale.
- (9) Operate the COARSE DELAY MS and FINE DELAY MS switches to their 0 positions and adjust the DELAY ZERO ADJ control to obtain a zero reading on the DELAY meter.

d. Measurements of delay may now be obtained by operating the MODULATION FREQUENCY HZ switch to the desired modulation frequency on both the transmitting and receiving TS-2669/GCM's. Operate the SWEEP-CARRIER-REFERENCE switch on the transmitting TS-2669/GCM to CARRIER. The line carrier frequency may now be adjusted by the CARRIER FREQUENCY control on the transmitting TS-2669/GCM.

e. A random check of the stability of the modulation frequency oscillators in both transmitting and receiving TS-2669/GCM's can be made by operating the SWEEP-CARRIER-REFERENCE control on the transmitting unit to REFERENCE and noting the delay reading at a fixed frequency. Since the REFERENCE FREQUENCY control is not used during a measurement, it always remains set to the same frequency; therefore, at any time during a measurement the operator can switch to the reference frequency to see that the delay reading at this frequency has not changed. If change indicates a drift in one of the master oscillators it can be corrected by repeating the synchronization procedure.

f. The lowest possible modulation frequency should be used during the measurements as the drift rate is directly proportional to the modulation frequency.

g. An absolute measurement of line delay cannot be made using end-to-end operation. Only the relative

delay of the line as a function of frequency can be determined.

### 3-5. End-to-End with Return Reference Mode

a. To perform a transmission line measurement using the return reference mode, it is necessary to have a TS-2669/GCM on the input to the line (fig. 3-4). It is also necessary to have a second line available to return the delay signal to the transmitting TS-2669/GCM.

b. The transmitting TS-2669/GCM, located at the input end of the transmission line to be measured, produces a modulated carrier signal in the pass band of the line. The signal is transmitted down the line to a TS-2669/GCM at the far end. The receiving TS-2669/GCM demodulates the test signal and uses this modulation signal to remodulate its own transmitting carrier signal as a reference carrier. This reference carrier is sent back to the transmitting TS-2669/GCM by way of the auxiliary transmission line. The operator using the transmitting TS-2669/GCM can now make delay measurements on his own unit.

c. Connect the TRANSMIT jack of the transmitting TS-2669/GCM to the input of the transmission line under test. Connect the RECEIVE jack of the transmitting TS-2669/GCM to the output of the auxiliary line (fig. 3-4). All controls and switches on the transmitting TS-2669/GCM are to be operated as described in paragraph 3-3.

d. Connect the output of the transmission line under test to the RECEIVE jack of the receiving TS-2669/GCM. Connect the input of auxiliary line to the TRANSMIT jack of the receiving TS-2669/GCM (fig. 3-4). Operate the switches and controls on the receiving TS-2669/GCM as follows:

(1) MODULATION FREQUENCY HZ switch to same modulating frequency used on the transmitting TS-2669/GCM.

(2) END TO END-REF RETURN switch to REF RETURN.

(3) SWEEP - CARRIER - REFERENCE switch to CARRIER.

(4) Operate CARRIER FREQUENCY control to provide an output carrier in the middle of the desired band.

(5) All other controls are to be operated as instructed in paragraph 3-3.

e. Delay measurements can now be made on the transmitting TS-2669/GCM. The operator at the transmitting end will control the carrier frequency

applied to the line under test and the TS-2669/GCM will read the relative delay of the line.

f. Amplitude response measurements are made on the receiving TS-2669/GCM by having the operator at this end of the line to monitor the dbm/% MODULATION meter as the operator at the transmitting end varies the carrier frequency.

### 3-6. Loop Mode

a. To perform a transmission line measurement using the loop method, it is only necessary to use one TS-2669/GCM at the input end of the line under test (fig. 3-5). At the far end of the line, the output is patched to the input of a second line used to return the test signal back to the input terminal. The delay and amplitude measurements are thus made over two transmission lines. If the two lines are of the same type, it is usually assumed that the forward and return path delays and amplitude characteristics are equal.

b. Connect the TRANSMIT jack of the TS-2669/GCM to the input of line No. 1 and the RECEIVE jack to the output of line No. 2.

c. Operate all switches and controls on the TS-2669/GCM as described in paragraph 3-3.

d. Delay and amplitude measurements can now be made by the operator of the TS-2669/GCM.

### 3-7. Operation under Unusual Conditions

Although the TS-2669/GCM has been designed to operate over a wide range of temperature and humidity, operation may be difficult in extreme cold, heat, humidity, moisture, and similar conditions. Observe the following procedures when operating under adverse conditions.

a. *Cold Climates.* Keep the equipment as warm and dry as possible. If the equipment has been exposed to the cold and then brought into a warm room, moisture will gather on the equipment. When the equipment reaches room temperature, dry it thoroughly.

b. *Hot Climates.* When the equipment is installed in tents, huts, or underground dugouts, provide the best ventilation. When the surrounding temperature drops, moisture will form on the equipment. Always dry the equipment thoroughly before operating it.

c. *Dry Climates.* Keep the equipment as free from (rust as possible).

CHAPTER 4

ORGANIZATIONAL MAINTENANCE

Section I. PREVENTIVE MAINTENANCE

4-1. Scope of Maintenance

a. *General.* Operator and organizational maintenance is the systematic care, servicing, and inspection of equipment to prevent the occurrence of trouble, to reduce downtime, and to maintain the equipment in serviceable condition. Preventive maintenance procedures are performed daily (para 4-2), monthly (para 4-3), and quarterly (para 4-4). Troubleshooting procedures are provided in paragraph 4-6. Defects that cannot be corrected by organizational maintenance personnel must be reported to higher category maintenance personnel. Records and reports of repairs and preventive maintenance must be made in accordance with procedures given in TM 38-750.

b. *Preventive Maintenance Checks and Services Periods.* Preventive maintenance checks and services are required daily (para 4-2), monthly (para 4-3), and quarterly (para 4-4). These checks must be performed during the specified periods. In addition, the daily checks and services must be performed under the following conditions:

- (1) When the equipment is initially installed.
- (2) When the equipment is reinstalled after removal for any reason.
- (3) At least once each week if the equipment is maintained awhile shut down.

c. *Cleaning.*

**Warning: Prolonged breathing of cleaning compound is dangerous; make sure that adequate ventilation is provided. Cleaning compound is flammable; do not use near a flame. Avoid contact with the skin; wash off any that spills on your hands.**

(1) Use a dry, clean, lint-free cloth or brush to remove dust and dirt. If necessary, moisten the cloth or brush with cleaning compound (Federal stock No. 6850-597-9742). After cleaning, wipe dry with a clean cloth.

**Warning: Compressed air is dangerous and can cause serious bodily harm. It can also cause mechanical damage to the equipment. Do not use compressed air to dry parts where cleaning compound has been used.**

(2) Dry, compressed air, not to exceed 60 pounds per square inch, may be used to remove dirt and dust from inaccessible places.

d. *Touchup Painting.* Remove rust and corrosion from metal surfaces by lightly sanding them with sandpaper. Brush two thin coats of paint on bare metal to protect it from further corrosion. Refer to the applicable cleaning and refinishing practices specified in TB SIG 364.

4-2. Operator's Daily Preventive Maintenance Checks and Services Chart

Sequence No.	Item to be inspected	Procedure	References
1	Exterior surfaces.....	Clean outside of cases, front panels, and meter faces.	Para 4-1c.
2	Cable connections.....	Check all cable connections and finger-tighten if necessary.	None.
3	Signal and power cables and cords.	Tighten loose connections of plugs and connectors. Check to see that insulation is not cut; remove kinks and strain.	None.
4	Indicator lamp .....	See that the POWER ON indicator lamp is lighted when the POWER switch is operated to ON.	Fig. 3-1.

**4-3. Organizational Monthly Preventive Maintenance Checks and Services Chart Sequence**

No.	Item to be inspected	Procedure	References
1	Mounting	Tighten loose nuts or bolts. Replace missing hardware as required.	None.
2	Knobs and switches	Rotate and operate all switches through all positions, observing that the mechanical action of each is smooth and free of external or internal binding. Replace or adjust as necessary.	None.
3	Power and signal cables	Repair insulation cuts and abrasions with electrical insulation tape.	None.
4	Plugs and jacks	Inspect all plugs and jacks for cracks, loose connections, or other deterioration. Adjust or replace as required.	None.

**4-4. Organizational Quarterly Preventive Maintenance Checks and Services Chart Sequence**

No.	Item to be inspected	Procedure	References
1	Completeness	Take an inventory of the equipment. Requisition missing and defective parts.	App B.
2	Publications	Check to see that all publications are complete, serviceable, and current.	DA Pam 310-4.
3	Modification work orders	Check to see whether any MWO's are required. Check equipment to see if applicable MWO's have been applied and MWO number is stamped as required. Perform modification or request modification as applicable.	See applicable MWO; see DA Pam 310-7 for MWO listings.
4	Cleanliness	See that the equipment is clean.	Para 4-1c.
5	Preservation	Check all surfaces for evidence of fungus. Remove rust and corrosion, and spot-paint bare spots.	Para 4-1d.
6	Fuses	See that the fuse is of the correct value (1 ampere). Check spare fuses for proper value and quantity.	Fig. 3-1.
7	Connections	Check to be sure that all connector pins, plugs, and receptacles are clean, intact, and not loose fitting.	Fig. 9-36.
8	Interior	See that all interior surfaces and mechanical assemblages are free of dust, dirt, oil, grease, moisture, corrosion, and rust. Clean if required.	Para 4-1c.
9	Internal wiring	Inspect all internal wiring, cables, and connections for broken, cracked, or defective insulation, or poor connections. Remake poor connections; repair defective insulation with electrical insulation tape, if possible. Clean the cables and connections, if required.	None.
10	Plug-in printed circuit cards	See that all printed circuit cards are installed securely.	Fig. 9-34.
11	Equipment operation	Perform a check of all operational features of the TS-2669/GCAM as follows: a. POWER switch to ON. b. REF RETURN-END TO END switch to END TO END. c. COUNTING TIME switch to 1 SEC.	None.

Sequence No.	Item to be inspects	Procedure	References
		<p>d. RECEIVE IMPEDANCE <math>\Omega</math> switch to 600.</p> <p>e. TRANSMIT IMPEDANCE <math>\Omega</math> switch to 600.</p> <p>f. RECEIVE LEVEL DBM switch to 0.</p> <p>g. TRANSMIT LEVEL DBM switch to 0.</p> <p>h. TRANSMIT LEVEL DBM control fully cw.</p> <p>i. TRANSMIT FREQUENCY switch to TRANSMIT FREQUENCY.</p> <p>j. SWEEP-CARRIER-REFERENCE switch to CARRIER.</p> <p>k. % MOD-RECEIVE LEVEL-TRANSMIT LEVEL switch to % MOD.</p> <p>l. MODULATION FREQUENCY HZ switch to 25.</p> <p>m. Operate % MOD ADJ control to obtain reading of 50 percent on dbm/% MODULATION meter.</p> <p>n. % MOD-RECEIVE LEVEL-TRANSMIT LEVEL switch to TRANSMIT LEVEL.</p> <p>o. dbm/%, MODULATION meter should read 0 dbm <math>\pm</math>0.5 dbm.</p> <p>p. RANGE (KHZ) switch to 50-600.</p> <p>q. Operate CARRIER FREQUENCY control to obtain reading of 50000 on FREQUENCY display (5,000 Hz).</p> <p>r. RANGE (KHZ) switch to .1-50.</p> <p>s. FREQUENCY display will read 05000 (5 KHz).</p> <p>t. SWEEP-CARRIER-REFERENCE switch to SWEEP.</p> <p>u. SWEEP CALIBRATE switch to LOW CAL.</p> <p>v. SWEEP TIME fully cw.</p> <p>w. Operate CARRIER FREQUENCY control to obtain 10000 on FREQUENCY display.</p> <p>x. SWEEP CALIBRATE to HIGH CAL.</p> <p>y. Operate the SWEEP WIDTH control to obtain reading of 20000 on FREQUENCY display.</p> <p>z. SWEEP CALIBRATE to SWEEP.</p> <p>aa. FREQUENCY display reading will slowly vary up and down between 10000 and 20000.</p> <p>ab. SWEEP-CARRIER-REFERENCE switch to CARRIER.</p> <p>ac. Connect BAL TRANSMIT jack to BAL RECEIVE jack using short cable with telephone plugs (TIP/RING).</p> <p>ad. dbm/% MODULATION meter should read 0 dbm <math>\pm</math>0.5 dbm.</p> <p>ae. Note reading of FREQUENCY display. Operate TRANSMIT FREQUENCY-RECEIVE FREQUENCY switch to RECEIVE FREQUENCY. FREQUENCY display reading should be the same as noted.</p>	

Sequence No.	Item to be inspected	Procedure	References
		<p><i>af.</i> DELAY METER RANGE MS switch to .15 - .5.</p> <p><i>ag.</i> FINE DELAY MS switch to 1 (black).</p> <p><i>ah.</i> COARSE DELAY MS switch to 0.</p> <p><i>ai.</i> Operate DELAY ZERO ADJ control to obtain DELAY meter reading of 0 on black 0 - .5 MS scale.</p> <p><i>aj.</i> DELAY METER RANGE MS switch to 3 - 10.</p> <p><i>ak.</i> DELAY meter should read 1 MS on black 0 - 10 MS scale.</p>	

**Section II. TROUBLESHOOTING, REPAIR, AND ADJUSTMENT**

**4-5. General**

Replacement and repair of the major unit and subassemblies of this equipment are authorized for the various categories of maintenance personnel as indicated in section II of the maintenance allocation chart (app C). The tools and test equipment required are listed in section III of the maintenance allocation chart. The troubleshooting information (para 4-6) is

based on symptoms which would be obtained while performing the operational checks in the preventive maintenance checks and services (paras 4-2, 4-3 and 4-4). When an abnormal indication is obtained, locate the symptom in the troubleshooting chart and perform the corrective measure indicated. If the corrective measure does not correct the trouble, refer the equipment to higher category maintenance personnel.

**4-6. Organizational Troubleshooting**

Item No.	Symptom	Possible trouble	Corrective measure
1	POWER ON indicator fails to light.	<p><i>a.</i> Failure of primary power source.</p> <p><i>b.</i> Blown fuse.</p> <p><i>c.</i> Defective indicator lamp.</p> <p><i>d.</i> Loose ac connection.</p>	<p><i>a.</i> Restore primary power source to operable condition, or obtain new primary source.</p> <p><i>b.</i> Replace fuse (fig. 3-1).</p> <p><i>c.</i> Replace indicator lamp (fig. 3-1).</p> <p><i>d.</i> Secure all ac connections.</p>
2	dbm/% MODULATION meter shows no indication (para 4-4 sequence 11m).	<p><i>a.</i> Meter amplifier not operating.</p> <p><i>b.</i> Low-pass filter not operating.</p> <p><i>c.</i> Countdown logic not operating.</p> <p><i>d.</i> 2 MHz oscillator not operating.</p> <p><i>e.</i> Front panel control defective.</p>	<p><i>a.</i> Replace assembly A12.</p> <p><i>b.</i> Replace assembly A13.</p> <p><i>c.</i> Replace assembly A10.</p> <p><i>d.</i> Replace assembly A4.</p> <p><i>e.</i> Refer to higher level of maintenance</p>
3	dbm/% MODULATION meter shows no indication (para 4-4 sequence 11o).	<p><i>a.</i> Sweep drive circuitry defective.</p> <p><i>b.</i> Modulator or mixer circuit defective.</p> <p><i>c.</i> Vfo circuit defective.</p> <p><i>d.</i> Front panel control defective.</p>	<p><i>a.</i> Replace assembly A16.</p> <p><i>b.</i> Replace assembly A14 or A15.</p> <p><i>c.</i> Refer to higher category of maintenance.</p> <p><i>d.</i> Refer to higher category of maintenance.</p>
4	FREQUENCY display does not read at all or reads erratically (para 4-4, sequence 11g).	<p><i>a.</i> Time base or reset generating circuits inoperative.</p> <p><i>b.</i> Vfo circuits defective.</p> <p><i>c.</i> Display circuit defective.</p>	<p><i>a.</i> Replace assembly A10.</p> <p><i>b.</i> Refer to higher category of maintenance</p> <p><i>c.</i> Refer to higher category of maintenance.</p>
5	FREQUENCY display does not read 10000 (para 4-4, sequence 11s).	<p><i>a.</i> Modulator/mixer circuit defective.</p> <p><i>b.</i> Sweep drive circuitry defective.</p>	<p><i>a.</i> Replace assembly A14.</p> <p><i>b.</i> Replace assembly A16.</p>
6	FREQUENCY display does not indicate frequency sweep (para 4-4, sequence 11aa).	<p><i>a.</i> Sweep drive circuitry defective.</p> <p><i>b.</i> Vfo circuitry defective.</p>	<p><i>a.</i> Replace assembly A16.</p> <p><i>b.</i> Refer to higher category of maintenance.</p>



Item No.	Symptom	Possible trouble	Corrective measure
7	dbm/% MODULATION meter does not indicate correct level (para 4-4, sequence 11ad).	<ul style="list-style-type: none"> <li>a. Input amplifier circuit defective.</li> <li>b. Front panel controls or wiring defective.</li> </ul>	<ul style="list-style-type: none"> <li>a. Replace assembly A6.</li> <li>b. Refer to higher category of maintenance.</li> </ul>
8	Receive frequency is <i>not</i> same as transmit frequency (para 4-4, sequence 11ae).	<ul style="list-style-type: none"> <li>a. Input amplifier circuit defective.</li> <li>b. Front panel controls defective.</li> </ul>	<ul style="list-style-type: none"> <li>a. Replace assembly A6.</li> <li>b. Refer to higher category maintenance.</li> </ul>
9	DELAY ZERO ADJ control does not give proper indication on DELAY meter (para 44, sequence 11a).	<ul style="list-style-type: none"> <li>a. Demodulator circuitry defective.</li> <li>b. Low-pass filter circuitry defective.</li> <li>c. Delay output circuitry defective.</li> <li>d. Delay logic not functioning.</li> <li>e. Front panel controls defective.</li> </ul>	<ul style="list-style-type: none"> <li>a. Replace assembly A6.</li> <li>b. Replace assembly A7.</li> <li>c. Replace assembly A8.</li> <li>d. Replace assembly A9.</li> <li>e. Refer to higher category of maintenance.</li> </ul>
10	DELAY meter does not give proper indication (para 4-4, sequence 11ak).	<ul style="list-style-type: none"> <li>a. Delay output circuit defective.</li> <li>b. Delay logic not functioning.</li> <li>c. Front panel controls defective.</li> </ul>	<ul style="list-style-type: none"> <li>a. Replace assembly A8.</li> <li>b. Replace assembly A9.</li> <li>c. Refer to higher category of maintenance.</li> </ul>

#### 4-7. Repair Procedures

To remove a plug-in printed circuit assembly, remove the top cover of the TS-2669/GCM by removing the screws. Remove the assembly with the card puller

supplied in the TS-2669/GCM. When replacing the assembly, be certain that the sides of the card are properly positioned in the card guides.

## CHAPTER 5

## FUNCTIONING OF EQUIPMENT

**5-1. Transmission Distortion**

a. *Types of Distortion.* Any communications medium (wire, radio, microwave, coaxial cable, etc) will degrade a signal passed through it because of at least three significant distortions.

(1) *Amplitude variation with frequency.* Typical circuits invariably have a high-frequency cutoff, and may have a low-frequency limitation.

(2) *Phase distortion.* If the transmission medium has a phase shift characteristic that is not linear (that is, if phase shift is not directly proportional to signal frequency), an effect known as delay distortion occurs.

(3) *Nonlinear amplitude response.* The system may have a response which is not linear with level, leading to harmonic and intermodulation distortion. However, this topic is not covered in the manual.

b. *Distortion Measurement.* The delay distortion of a transmission system is more difficult to measure than amplitude response. If delay distortion is present, certain frequencies in a signal band will be delayed more than others. The effect of this differential delay on a system depends on the information characteristics. For instance, moderate amounts of delay distortion have comparatively small effects upon voice transmission, since the ear is not particularly sensitive to phase variations. On the other hand, differential delay on a channel used to transmit complex information, such as radar, video, or television, can result in a large degradation of the received signal. Delay distortion on a high-speed data link can result in a prohibitive error rate, or a completely unusable channel.

**5-2. Concept of Envelope Delay**

a. The simplest form of time delay is the absolute transmission delay of a signal traveling from one point in a circuit or system to another. When the signal is a single pulse or a burst of pulses, the absolute time delay can be determined. A dual trace oscilloscope with a common synchronization trigger could be used to make

this measurement. The oscilloscope measurement can be read directly in terms of time, or in the case of a sine wave, time can be computed by a knowledge of phase shift and frequency (fig. 5-1). The time delay is proportional to the phase shift divided by the frequency.

b. In actual practice, for perfect data transmission it is only necessary that all frequencies in the information band be delayed by the same amount of time. No arbitrary amount of time delay has to be realized. The constant time delay associated with this ideal transmission system will cause only a time delay in the reception of the information, but no distortion.

c. The requirement for a constant delay for all frequencies in a band can be interpreted as requiring a constant differential phase shift versus frequency.

d. The phase characteristics outside the frequency band may have shape without affecting the information transmission.

**5-3. Delay Measurement**

Measurement of transmission delay is most conveniently accomplished by the scheme shown in figure 5-2. A carrier frequency oscillator with an output frequency  $f_c$  in the desired frequency range is amplitude-modulated with a relatively low frequency,  $f_o$ . This modulated signal is passed through the network under measurement (e.g. transmission line), and the output is demodulated to recover the modulating signal  $f_o$ . The recovered modulating signal,  $f_o$ , is then compared in phase with the original modulating frequency,  $f_o$ . The phase meter is calibrated to read in milliseconds the amount of time delay incurred by the modulating waveform as it passed through the network under test. This delay of the modulating frequency,  $t_d$ , corresponds to the delay incurred by the carrier frequency  $f_c$ , which is of prime interest.

**5-4. Block Diagram Analysis**

(fig. 5-3)

a. *Carrier Frequency Generation.* The carrier frequency generator in the TS-2669/GCM uses a

heterodyne method for providing the output signal. A variable frequency signal (1) is generated in the variable frequency oscillator assembly (A2) which is buffered in A16 to provide 2-2.6 MHz and 200 kHz-260 kHz range signals (3 and 4). The 2 MHz oscillator (A4) provides a stable 2 MHz signal (2) which is divided by 10 in A10 to provide a 200 kHz signal (5). Signal No. 2 is modulated in A14 and then heterodyned with signal No. 3 to give an output signal in the 50 kHz to 552 kHz range (6). Signal No. 5 is modulated in A15 and then heterodyned

with signal No. 4 to provide an output signal in the 0.1 kHz to 50 kHz range (7). Signal range (6) or (7) is then selected by switch S3 and output amplifier A12 amplifies the modulated signal and sends it to the TRANSMIT output.

b. *Modulation Frequency Generation.* The modulating frequencies of 25 Hz, 83 1/3 Hz, and 250 Hz are generated by digital logic division from

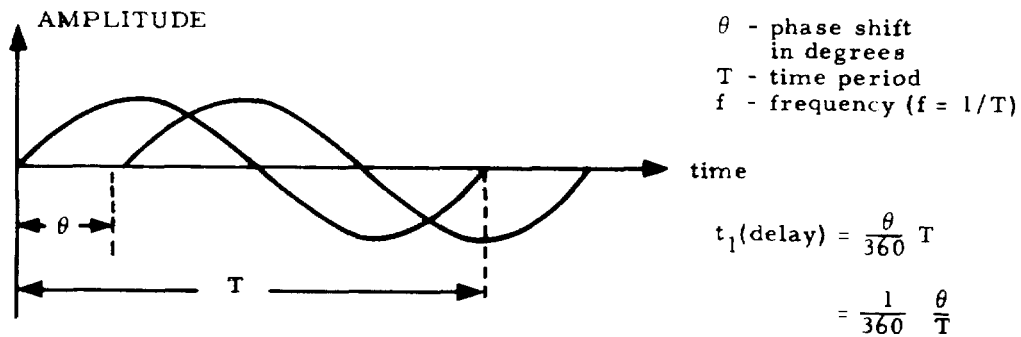

EL 6625-922-15-9

Figure 5-1. Time Delay.

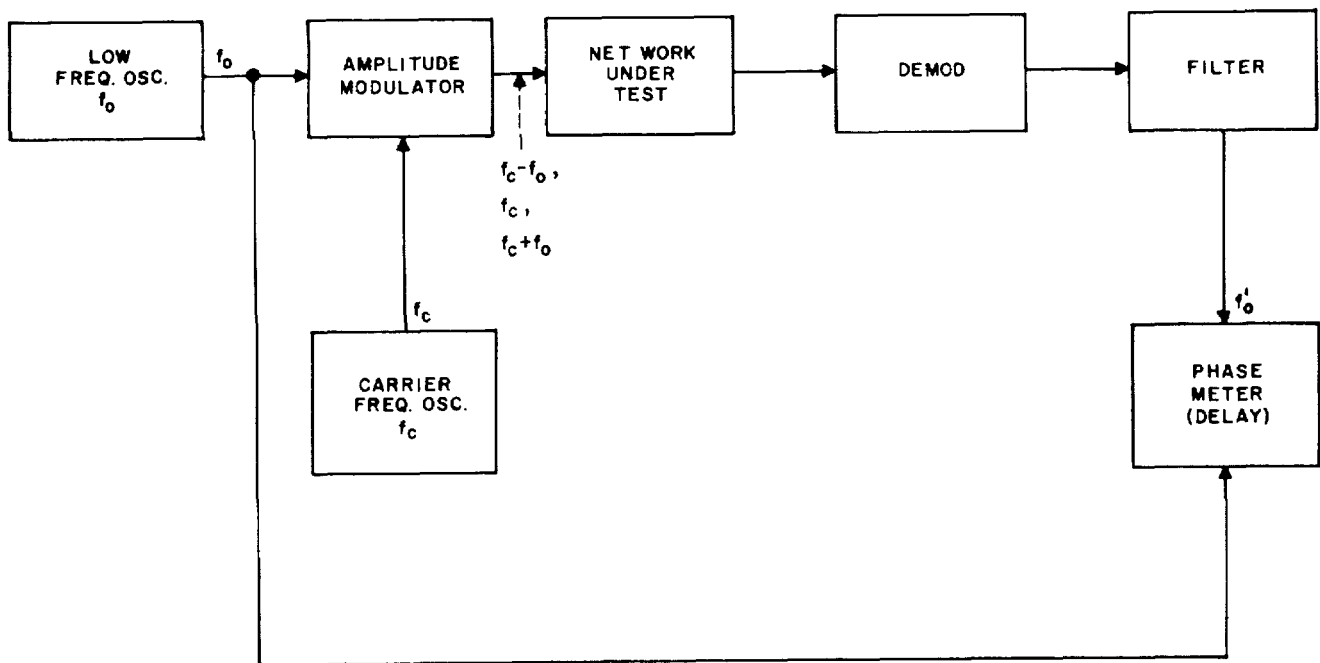

EL 6625-922-15-10

Figure 5-2. Basic delay measuring system.

the stable 2 MHz oscillator (A4) output (2). Signal No. 2 is divided in the countdown logic assembly (A10) and passed (8) to delay logic assembly (A9) where it is further divided to produce a square wave at the proper frequency (9). This square wave (9) is passed through an active low pass filter assembly (A13) where it is filtered to a sine wave (10). Signal No. 10 is then passed to the modulating signal inputs of assemblies A14 and A15.

*c. Delay Reference Signal Generation.* The delay reference signal used to make the phase comparison in delay output assembly (A8) is generated from the stable 2-MHz signal (2) from A4. This signal is divided in A10 and A9 to provide a chain of pulses (11) to the coarse and fine delay switches (12). The signals at No. 12 are further gated in A8. This sequence is explained in detail in paragraph 5-5.

*d. Receiving Circuits.* The signal at the receive input is amplified and demodulated in A6 and the demodulated signal (13) is passed through A7 where all the carrier components are filtered out to leave only the modulating signal (14) which has been delayed by the amount of carrier frequency delay in the transmission line.

*e. Frequency Sweeping.* The variable frequency oscillation (A2) can be electronically swept over its frequency range by a triangular waveform (15) generated in the sweep drive assembly (A16). This electronic sweeping capability substitutes for the manual front panel carrier frequency control.

*f. Analog Outputs.* Each meter and the digital display provide dc output signals proportional to their readings. These output signals are brought out to the rear panel terminal strip. The analog frequency signal is generated in A3 from input signal No. 16. The analog delay signal is generated in A3 from signal No. 17. The analog level signal is generated in A12 from signal No. 18.

## 5-5. Description of Logic

(fig. 5-4)

*a. Logic for Delay Measurement.* The time period of the modulation signal is divided into 80 equal time segments by logic circuitry within the TS-2669/GCM. These 80 time segments are selected by the COARSE DELAY MS switch (four-position) and the FINE DELAY MS switch (20-position). The full scale of the DELAY meter can then be used to indicate 1/80th of a time period. This method is used to determine the phase (or time) relationship of two signals of the same frequency, which correspond to a measurement of envelope delay.

(1) A 2-MHz signal derived from a precise crystal-controlled oscillator is divided by 10 (M2/A10), then divided by 5 to provide a 40-kHz signal (M3/A10). This signal is divided by 3 (M4/A10, M5/A10) and also divided by 10 (M6/A10), producing three signals, selectable by the MODULATION FREQUENCY HZ switch (SIB) to provide the modulating frequencies of 250, 83-1/3, and 25 Hz; then the signal at SIB is divided by 2 (M1/A9), divided by 5 (M2, 3, 4/A9), divided by 4 (M5, 6/A9), and then divided by 4 (M7, 8/A9). The last three dividers provide a total division of 80, for deriving the time segments. A double level AND gating system, consisting of gates CR1, CR2, CR3 (T1) through CR25, CR26 (T13) on assembly A9, is used to decode and select 1 out of 80. The decoding matrix progress is from 80 to 13 to 3 to 1. The input signal to the divide-by-80 (M1/A10 pin 6) is used as a final Strobe signal to eliminate any ambiguity in decoding. The time pulse thus generated at AND gate CR3, CR4, CR5 and CR6 on assembly A8 is used to set flip-flop M1/A8. The demodulated input signal from ST/A8 is then used to reset flip-flop M1/A8. The one output (Q) of the flip-flop is low-pass filtered to recover the average direct-current (dc) level, which corresponds to the duty cycle, or time between set and reset signals. The DELAY meter indication is proportional to the dc voltage.

(2) A constant offset equivalent to approximately 25 percent of a time period is used in both the digital and the analog circuitry. When the coarse range is being used, the flip-flop output pulse should be between 25 and 50 percent of the time. When in the fine range, the output should be between 25 and 26.5 percent, to prevent wild voltage changes near zero on the DELAY meter. Without an offset, an output pulse with a 2 percent variation around 0 percent would produce duty cycle extremes of 1 and 99 percent instead of 24 to 26 percent with the present system. The DELAY meter cannot accept the abrupt voltage changes.

*b. Logic For Frequency Measurement* (fig. 5-4 and 5-5)

(1) Timing for frequency measurement is derived from the same 2-MHz oscillator used for delay measurement. The 4-kHz signal (M6/A10 pin 12) is divided by 40 to derive a 100-Hz signal (M10/A10), then divided by three groups of 10 (fig. 5-5) (M11/A10, M12/A10, M13/A10) to provide 10, 1, and 0.1-Hz signals for the sampling time interval to count input pulses. COUNTING TIME switch (S7) selects one of

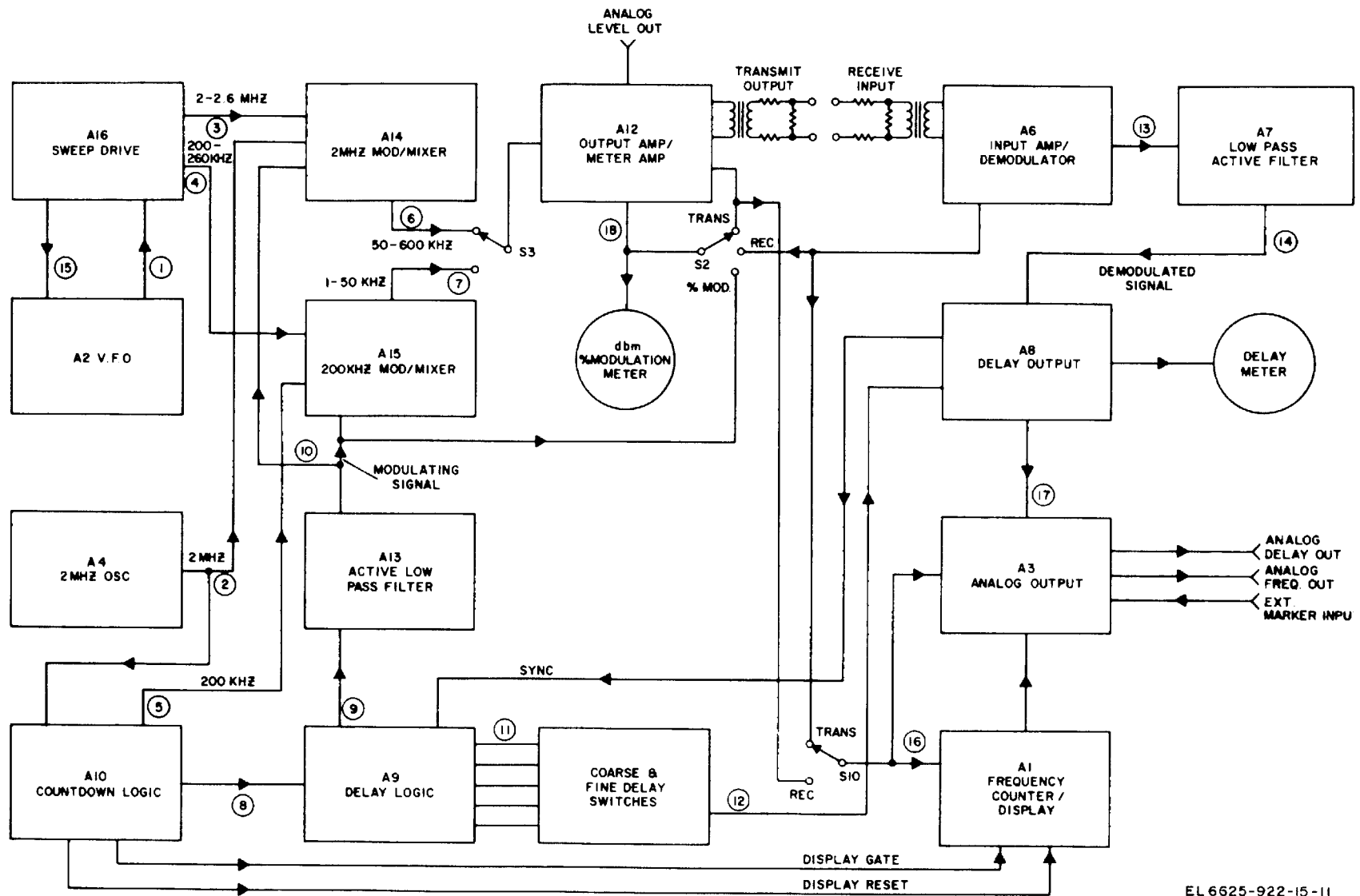

EL 6625-922-15-11

Figure 5-3. Simplified block diagram.

these signals by enabling one AND gate and inhibiting the other two AND gates (M1/A10). The signal goes through an OR gate (M7A/A10), and is used to reset the gate signal. Two flip flops are tied together to operate as an ac set-reset flip-flop; that is, the flip-flop responds only to logic level transitions, not dc levels. The gate signal is taken from such an ac flip-flop (M14/A10, M15/A10), being set by the 100-Hz signal, which is synchronous with the other timing signals. When the gate signal is reset, the display control flip-flop (M16/A10, M17/A10) is set, thereby holding the lighted numbers in the readout display. The display control flip-flop is reset by 1 Hz, giving a display time of 1 second (or 0.9 second in the .1 SEC position of the COUNTING TIME switch). The reset control is activated for 1 period of the 100-Hz signal (10 milliseconds (ms)).

(2) The input sine-wave signal is squared by the input circuit (Schmitt trigger ST1/A1), and then sent to the input of an AND gate (M11A/A1). A gate signal on the other input of the AND gate (M1A/A1) allows input pulses to pass for a time, as selected by the COUNTING TIME switch. The signal then goes through five decade registers (M2, 3, 4, 5, 6/A1). Each decade counter then drives a decoder/driver (M7, 8, 9, 10, 11/A1), which drives a lighted numerical indicator (DS1, 2, 3, 4, 5/A1). At the end of the counting interval, the number is displayed for about 1 second, the register is reset, and the process repeated.

c. *Synchronization Logic* (fig. 5-4). SYNC pushbutton S12 provides a means of zeroing the delay reading for a reference carrier signal, when operating in the end-to-end mode. When two oscillators are at exactly the same frequency, they can still have an arbitrary phase relationship. When the SYNC pushbutton is depressed, most of the flip-flops in the timing logic are reset to zero by M20/A10 and M21/A10. While the pushbutton is still depressed, the next edge of the incoming modulating signal allows the counting logic to free run. In this way, the two oscillators can be synchronized. The pushbutton logic is designed so that as long as the pushbutton is not depressed, all counting logic can run normally. The Strobe flip-flop (M1/A9) is preset to a one, since the decoding logic lags the timing logic by one-half a clock period to prevent false triggering. Presetting of the Strobe flip-flop compensates for the half period offset.

**5-6. Integrated Circuits**

a. *General.* Several types of integrated circuits are used in the TS-2669/GSA1. This paragraph contains a brief description showing their general characteristics and method of operation.

No.	Types	Model No.
1	Dual 4-input gate	MC830P
2	Power gate	MC844P
3	Quad 2-input gate	MC846P
4	Clocked flip-flop	MC845P
5	Dual flip-flop	SN7473N
6	Decade counter	SN7490N
7	Decoder/driver	SN7441N

b. *Logic Circuits.* The first types listed in a above are logic circuits, and the following positive logic definitions apply:

Logical 1 = high voltage (+2.4v to +5.0v)

Logical 0 = low voltage (0.0v to 0.5v)

**Note.** Any unused input is equivalent to a logical 1.

c. *Gates* (A, fig. 5-6 and A, fig. 5-7) The gates (first three types listed in a above) are all NAND gates and operate as follows:

Inputs	Output
Any input = 0	1
All inputs = 1	0

d. *Flip-Flops.* The two outputs of the flip-flops (types 4 through 6) should usually be opposite logically (one output should be a logical 1 and the other should be a logical 0). For the TS-2669/GCM, the flip-flops are used mostly as frequency dividers. The timing for the divide-by-2 mode is shown in B, figure 5-7. Note that the flip-flop can change state on the 1 to 0 transition of the clock input. The flip-flops also have a dc input for resetting (or setting) that overrides the clock input. These inputs are used for establishing the desired initial conditions.

e. *Clocked flip-flop (MC845P)* (C, fig. 5-6). This flip-flop operates according to the following chart:

		$t_n$		$t_{n+1}$
S <sub>1</sub> (pin 2)	S <sub>2</sub> (pin 3)	C <sub>1</sub> (pin 9)	C <sub>2</sub> (pin 8)	Q (pin 4)
0	x	0	x	Q <sub>n</sub>
0	x	x	0	Q <sub>n</sub>
x	0	0	x	Q <sub>n</sub>
x	0	x	0	Q <sub>n</sub>
0	x	1	1	0
x	0	1	1	0
1	1	0	x	1
1	1	x	0	1
1	1	1	1	U

Notes:

1. x-state of the input does not affect the state of the circuit.
2. U-Indeterminate state.
3. A logical 0 applied to the C<sub>D</sub> input clears the flip-flop to 0.
4. A Logical 0 applied to the S<sub>D</sub> input sets the flip-flop to 1.

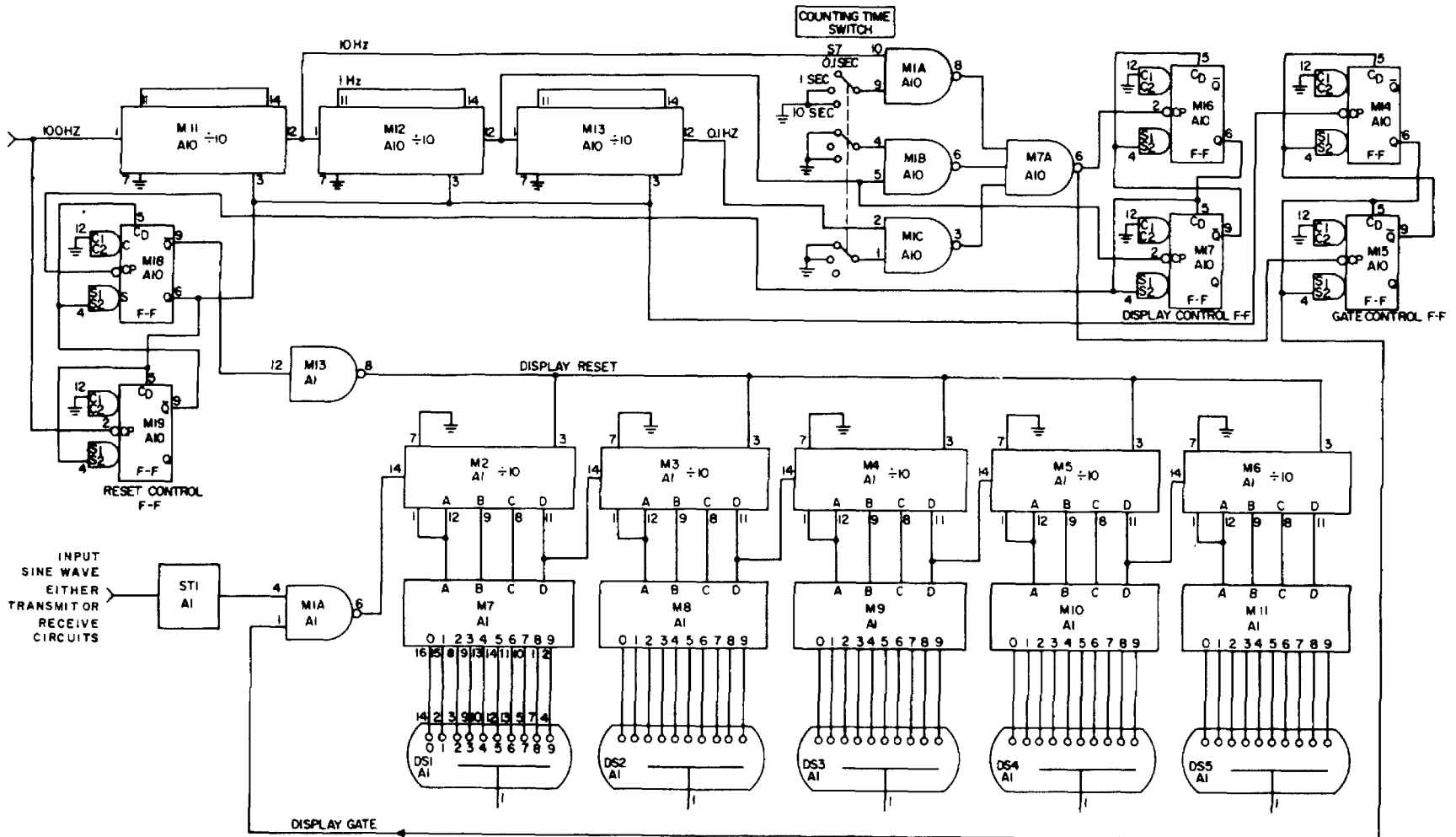

EL 6625-922-15-13

Figure 5-5. Frequency counter display logic.

f. *Dual flip-flop (SN7473N)* (D, fig. 5-6). This integrated circuit contains two flip-flops, and is used in the divide-by-4 mode (C, fig. 5-7).

g. *Decade Counter (SN7490N)* (E, fig. 5-6). This integrated circuit contains four flip-flops, and is used for divide-by-5, divide-by-2, or divide by-10 (Mode D, fig. 5-7). The counter can be reset to 0's by applying a logical 1 to an R<sub>0</sub> input.

h. *Decoder/Driver (SN7441N)* (F, fig. 5-6). This integrated circuit takes the outputs from an SN7490N decade counter, decodes the input for 1 out of 10, and then drives an indicator lamp. The selected output will be a low voltage (near ground). The circuit operates according to the following chart:

Input				Output selected
D	C	B	A	
0	0	0	0	0
0	0	0	1	1
0	0	1	0	2
0	0	1	1	3
0	1	0	0	4
0	1	0	1	5
0	1	1	0	6
0	1	1	1	7
1	0	0	0	8

j. *Linear Amplifier (uA702C)* (G, fig. 5-6). This integrated circuit is an operational amplifier, with high gain, dc, differential operation. Pin 2 is the inverting input (a positive input causes a negative output). Pin 3 is the noninverting input.

k. *Physical Configuration* (fig. 5-8). All logic circuits are in the dual in-line package. The linear circuit is in a modified TO-5 package. Viewed from the top, pin numbers run counterclockwise.

### 5-7. Circuit Descriptions

a. *2-MHz Oscillator A4* (fig. 9-3). Crystal Y1 controls the frequency of the oscillator stage composed of transistors Q1, Q2, and Q3. Q2 is a common-base amplifier, and Q1 and Q3 are used as a compound emitter follower. The crystal determines the frequency by being in the direct feedback loop. Varactor diode CR1 is a voltage-variable capacitor in series with the crystal, and can be used to vary the frequency slightly by the application of a dc back-bias to the diode through pin H. The 2-MHz signal is amplified by stages Q6 and Q7, rectified and voltage doubled by CR3, and CR4, and C14, and this dc level is amplified by Q8. The output of Q8 controls the bias of Q4 and QS, which are used as diodes with a variable impedance, to provide an

automatic gain control (agc) of the signal level. The signal is fed to tuned-amplifier stages Q9, Q10, and to Q11, Q12, Q13, Q14 which comprise a compound emitter follower. Transistor Q15 is a squaring circuit, which converts the sine wave to a square wave, with voltage levels between ground and + 5 volts.

b. *Variable-Frequency Oscillator A2* (fig. 9-5). The variable-frequency oscillator (vfo) is a modified Colpitts, with an inductor, split capacitors, and tuning by means of a variable capacitor across the tuned tank. Inductors L1 and L2 in series form the inductor, capacitors C2 and C3 are the split capacitors, and the variable capacity is switched in by front panel controls. Transistor Q1 is a common-base amplifier for the oscillator section. Feedback is from emitter to base. The output signal from the collector is a rectangular wave, and is fed to emitter follower Q2. A negative voltage applied to varactor diodes CR1 and CR2 is used to vary the capacitance of the circuit.

c. *Sweep Drive A16* (fig. 9-7). This circuit is a free-running oscillator, generating a negative triangle wave, with a constant base line voltage of about -0.5 volt, and independently variable amplitude and frequency. Positive current source Q15 and negative current source Q16 are alternately turned on and off to charge and discharge capacitor C8. The charge-discharge rate is determined by the SWEEP TIME control. The voltage across the capacitor is fed to compound emitter follower Q1, Q2, then applied to Schmitt trigger Q5, Q7. The generated triangle wave has a dc voltage that is between the two threshold voltages of the Schmitt trigger. Stages Q9, Q11, and Q12 are switches for controlling the current sources. When positive source Q15 is conducting, its emitter is tied through a resistor to +12 volts; Q16 is not conducting because its emitter is connected to ground. When the upper threshold voltage of the Schmitt trigger is reached, the switching circuits change and Q15 is cut off (emitter connected to ground) and Q16 is turned on (emitter connected to -12 volts). The capacitor voltage now heads down toward the lower threshold voltage, and the process is repeated. Transistors Q3, Q6, Q8, and Q10 comprise a dc operational amplifier. Resistor R1, in conjunction with variable resistor R4, provides a dc level shift, so that the baseline voltage applied to the amplifier (at the junction of R1 and R6) can be 0 volt. Transistors Q3 and Q6 are a differential amplifier, transistor Q8 is an amplifier with a gain of 3, capacitor C2 is used to reduce gain at high frequencies to insure stability, and transistor Q10 is an emitter follower. A variable feedback resistor is between pins C and J, varied by the SWEEP WIDTH control, which varies the amplitude of the output triangular wave.



Resistors R25 and R27 shift the dc level of the output signal so that the baseline at pin E is about -3 volts, instead of 0 volt at pin C. Resistors R32, R33, and R52 are used in a network to generate test voltages to the input of the operational amplifier for statically determining the end frequencies when in the sweep mode. The resistors are switched in and out by the SWEEP CALIBRATE switch. Transistor Q14 is a switching circuit the input at pin R of which is the output of the variable frequency oscillator, 8 to 10.4 MHz. Integrated circuit M2 operates as a divide-by-4 and M1 is a divide-by-10, giving square-wave outputs between ground and approximately +5 volts. A positive pulse is

produced at the sweep sync output at the start of each sweep.

d. 2-MHz Modulator Mixer A14 (fig. 9-9). This circuit has three inputs: 2 MHz square wave, sine-wave modulating signal (25, 83-1/3, or 250 Hz), and a vfo 2- to 2.6--MHz square wave. The output is a modulated sine wave, between 0 and 600 kHz. Transistors Q1 and Q5 are emitter-follower buffers for the 2-MHz and modulating signals, respectively. The two frequencies are mixed in Q3, then fed to two 2-MHz tuned amplifier stages, Q7, Q8 and Q9, Q10. Transistors Q11 and Q12 comprise a compound emitter follower. The vfo input is sent to amplifier Q18 and emitter

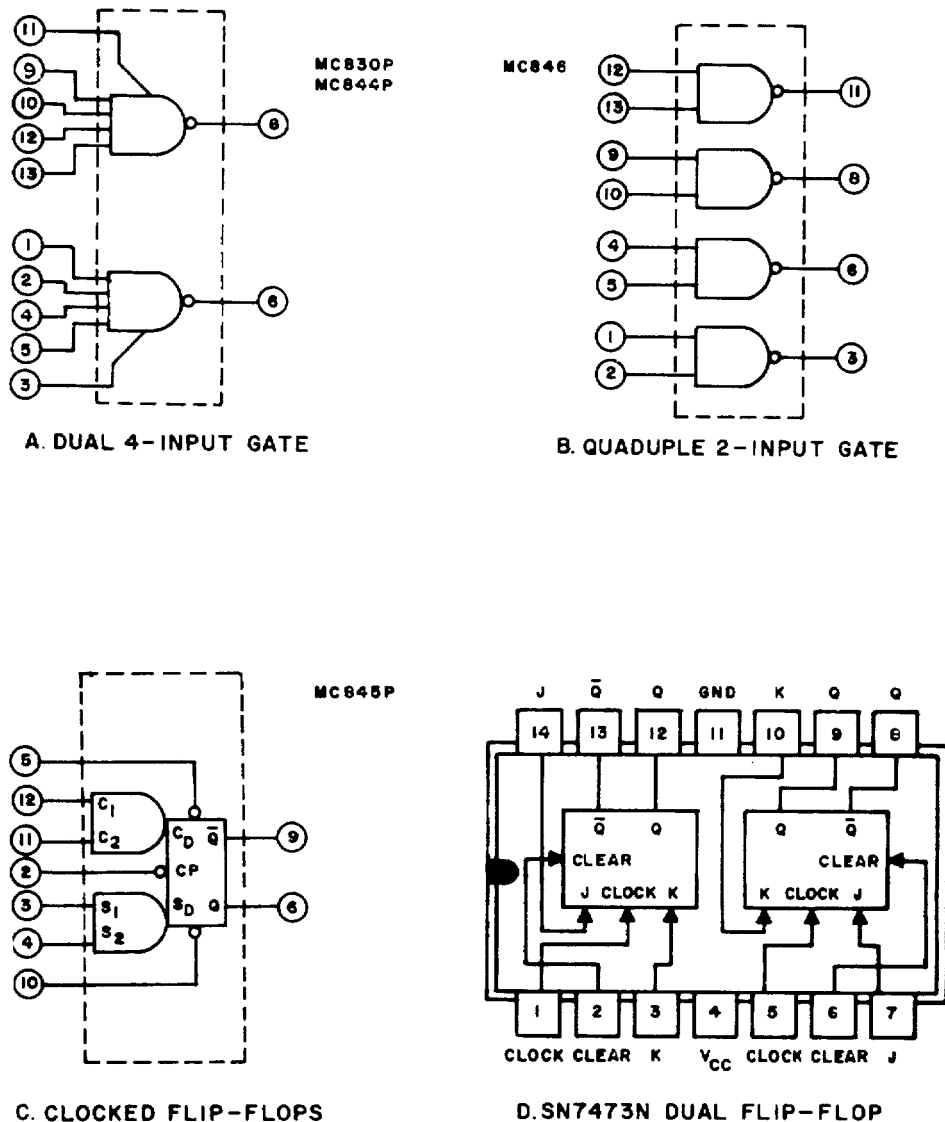

Figure 5-6(1). Pin connections of integrated circuits (part 1 of 2).

follower Q17. The vfo signal and the modulated 2-MHZ signal are mixed in stage Q13, 14; the output is sent to compound emitter-follower Q15, Q16, and then to a low-pass inductance-capacitance (lc) network to select only the difference frequency, 0- to 600-kHz modulated sine wave.

e. *200-kHz Modulator Mixer.* A15 (fig. 9-11). The operation of this circuit is similar to that of the 2-MHz modulator mixer. The inputs are a 200 kHz square wave, a sine-wave modulating signal at pin A, and a vfo 200- to 260-khz square wave. The output is a modulated sine wave, between 0 and 60 khz.

f. *Low-Pass Active Filters 1A7 and A13* (fig. 9-13). Transistors Q4 and Q7 represent a single active filter section. The products of R13 and C4, and R16 and C7 determine the cutoff frequency of the low-pass filter.

Transistors Q4 and Q7 together give a voltage gain of slightly less than unity, with feedback from the emitter to the base of Q4. Four active filter sections in cascade provide the desired frequency response; near unity gain from dc to near 25Hz, then rapid attenuation of higher frequency components. An external variable resistor (front panel DELAY ZERO ADJ control) is used across R16 in the fourth stage to give a variable phase shift for setting initial conditions. The input at pin V is a signal with 25 Hz modulation; the output at pin Y is the 25-Hz sine wave. The operation of the 83-1/3-Hz and 250-Hz active filters are similar. Resistors R61, R63, and R65 are selected values used only on A13 to give a fixed phase shift in the filters. On A7, the phase shift is adjustable by the DELAY ZERO ADJ front panel control.

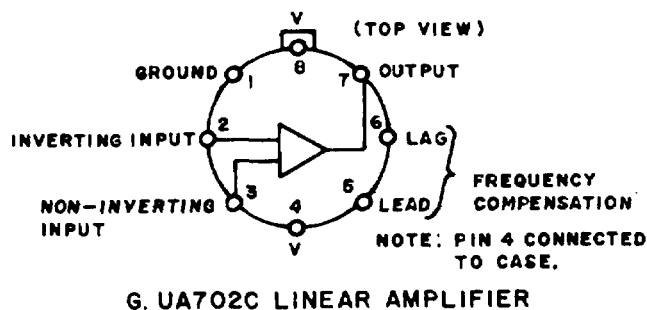
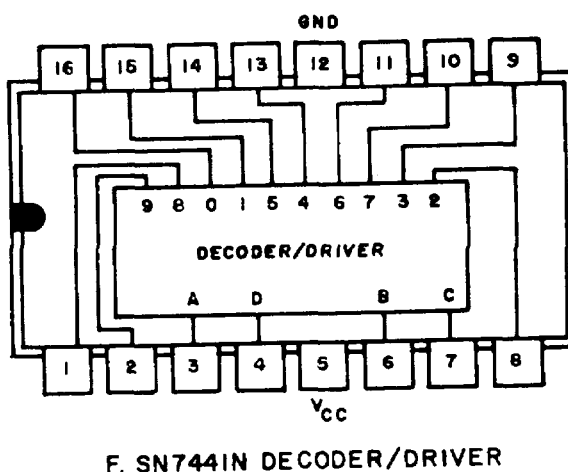
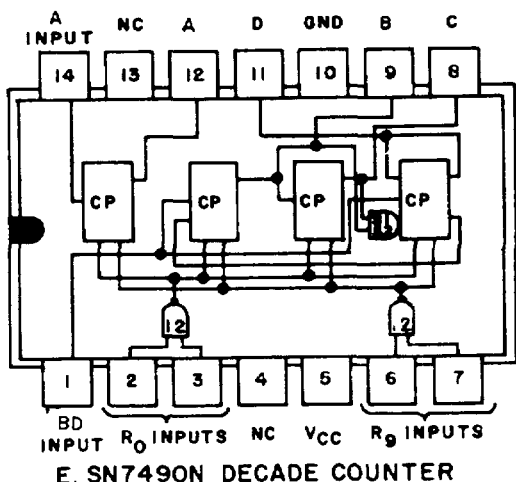

EL 6625-922-15-14 (2)

Figure 5-6(2). Pin connections of integrated circuits (part 2 of 2).

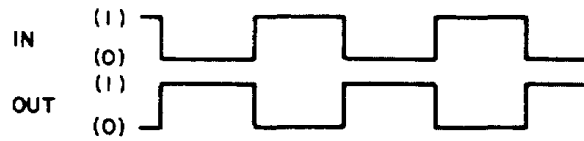

A. DIAGRAM FOR GATE

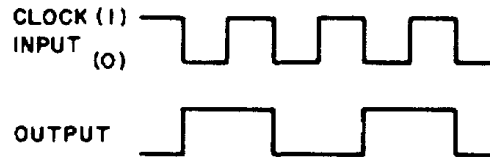
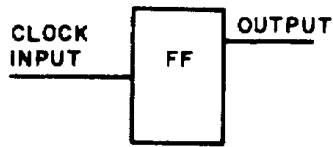

B. FLIP-FLOP IN DIVIDE-BY-2 MODE

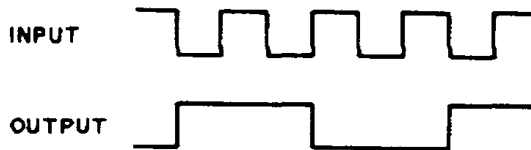
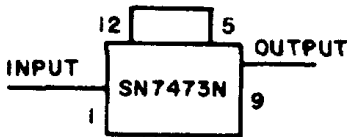

C. DUAL FLIP-FLOP, SN7473N, IN DIVIDE-BY-4 MODE

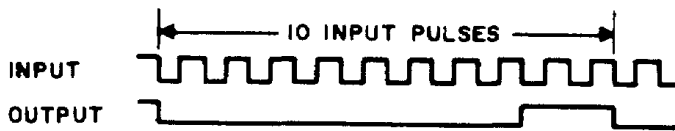
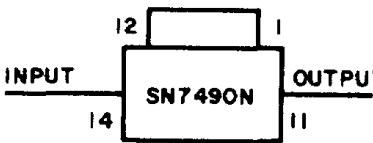

D. DECADE COUNTER, SN7490N, IN DIVIDE-BY-10 MODE

EL 6625-922-15-15

Figure 5-7. Timing of integrated circuits.

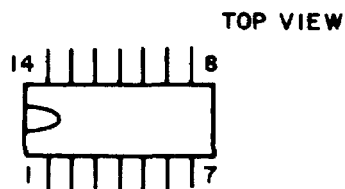

A. DUAL IN-LINE

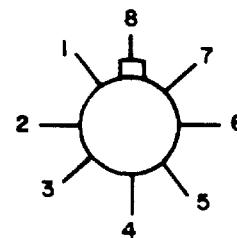

B. TO-5

EL 6625-922-15-16

Figure 5-8. Integrated circuit packages, pin numbers.

by the DELAY ZERO ADJ front panel control.

*g. Input Amplifier and Demodulator A6* (fig. 9-16). The input to this circuit is a modulated sine wave. The output is a full-wave rectified sine wave with the envelope of the peaks following the low-frequency modulating sine wave. Amplifiers A1 and A2 are integrated circuit dc amplifiers. Resistor R1 is the input resistor, and resistor R3 is the feedback resistor for A1. The stage has an overall gain of 31.6 ( $R3/R1$ ). Most of the other passive components connected to the integrated circuit are used for frequency compensation. Amplifier A2 has resistor R7 and variable resistor R9 in the feedback loop. Transistor Q2 is a current source for the differential amplifier, full-wave demodulator Q1 and Q3. The output signal from A2 is applied to bridge diode CR2 through CR5 to start turning Q1 on during the positive half cycle and to start turning Q3 off during the negative half cycle, causing the full-wave demodulation. Transistor Q4 is an emitter follower. Transistor Q5 is an emitter follower for the complete signal from the output of A2 before being applied to the meter circuitry.

*h. Output Amplifier and Meter Amplifier A12* (fig. 9-18). This module contains a 30-db amplifier, a 7.8-db amplifier, and a meter driving amplifier. It also provides a dc analog output proportional to the meter indication. The input modulated signal is applied to emitter-follower Q1, then routed through a variable resistor (front panel TRANSMIT LEVEL DBM control) for attenuation. The signal is sent to the integrated circuit amplifier A1, which with output driver stage Q4, Q5, feedback resistors R26 and R9, and input resistor R6, gives an overall gain of approximately 32. Stages Q6 through Q12 represent an amplifier which, with its input resistor R33 and feedback resistors R36 and R37, give an overall gain of 2.4 (7.8 db). There are two differential stages Q6, Q8 and Q9, Q10. Stage Q11, Q12 is a push-pull emitter-follower output stage. A signal level input at pin K or a percentage modulation input at pin L is selected by the % MOD - RECEIVE LEVEL-TRANSMIT LEVEL switch. Integrated circuit amplifier A2 drives diode-capacitor network CR6, CR7, and C12, C13 in a feedback configuration. A dc voltage proportional to the input is developed across C12 and C13 for driving the meter. Network R31, R32, and C16 provide dc feedback for bias stability, but little ac feedback so that the ac signal can be amplified. The signal applied to emitter-follower Q3 is rectified and filtered by CR1 and C3, then fed to emitter-follower Q2 to provide the analog meter dc voltage.

*i. Analog Frequency Output A3* (fig. 9-20). This circuit provides an analog delay output which is a dc level that varies directly with the delay reading in the instrument. When an external marker input is applied, a series of pips is superimposed on this dc level whenever the frequency input approaches and passes the frequency of the external marker input. The frequency input is a square wave, and the analog frequency output is a dc level proportional to the logarithm of the input frequency. Both outputs become more positive as the analogous parameter increases. Transistors Q1 and Q3 are a Darlington amplifier, the output of which feeds push-pull switch Q4, Q5 to produce a square wave at TP1. The external marker input applied through emitter-follower Q6 is used as the supply voltage in mixer Q7, Q8. These two transistors are operated in the inverted mode, and alternately switched on and off by the input signal. The mixed signal appears at TP2, and is then sent through emitter-follower Q12 to a two-section, low-pass filter, R38, C16 and R39, C18. This ac signal is added to the filtered delay pulse input signal (filtered by R45 and C20) at the input of emitter-follower Q15. The frequency input is also applied to emitter-follower Q2, and then to the diode-capacitor-resistor network. The capacitor values differ by factors of 10, to stagger the log characteristics of the diodes and to produce a four decade dynamic frequency range. The log voltage thus generated is fed to feedback amplifier Q9 through Q13.

*j. Delay Output A8* (fig. 9-22). This circuit drives the DELAY meter, which gives a direct indication of the phase difference (or difference in time) between a reference timing signal and the demodulated input signal. Four precise timing signals (pulse 1, pulse 2, pulse 3, and strobe) are combined in AND gate Q4 to produce a negative pulse at TP1 whenever all four inputs are at logical ONE (positive voltage). The output of integrated circuit flip-flop M1 (TP2) goes positive when the pin 10 input goes negative (ground). Test point TP2 goes to ground when the pin 2 input, which corresponds to the demodulated input signal, makes a negative-going transition. The output of the flip-flop, therefore, remains positive only during the time between the occurrence of a reference timing pulse and the leading edge of the modulation input signal. The two signals are at the same frequency; therefore, the flip-flop output gives a direct indication of the relative timing or phase difference by its duty cycle. Transistors Q5, Q7, and Q8 are used as a switch to generate the two levels of ground and +12 volts at TP3.

Transistor Q14 is a voltage source, the emitter of which is set at approximately +3 volts. Pin H is connected to either pin Z or Y, as selected by the DELAY METER RANGE MS switch. The input rectangular wave is filtered by series resistors R51 and R52, or R54 and R55, and capacitor C16 so that a constant proportion of the dc component can be read by the DELAY meter, thus converting duty cycle to a time reading. One end of the meter is referenced to +3 volts, so that a 25-percent duty cycle would be interpreted as zero delay. The sine-wave input modulating signal is applied at pin A. Transistors Q1, Q2, and Q3 make up a feedback amplifier with a gain of approximately 5. The sine wave is then fed to diode bridge CR11 through CR14, which acts as a zero-crossing detector. The square waves at C8 are sent to integrated circuit amplifier A1 which with feedback provides a gain of about 47. Transistor Q10 is a current source for Schmitt trigger Q9, Q11 which receives the signal from emitter-follower Q6. The threshold of the Schmitt trigger is set by voltage source Q12, the base voltage of which is set by the tap position of resistor R58, R59 or R68. The three thresholds are used for the three modulating frequencies, and are automatically switched in by the MODULATION FREQUENCY HZ switch. The output of the Schmitt trigger is sent to switch Q13, then to switch-inverter Q16 to obtain the proper polarity for activating flip-flop M1.

k. *Countdown Logic A10* (fig. 9-24). The main input to this assembly is a 2-MHz square wave at pin B. By counting down this frequency, most of the timing signals required in the TS-2669/GCM are derived. The 2-MHz input is gated with a synchronization signal from flip-flop M20 in gate M1. Circuit M2 is a divide-by-10, and M3 is a divide-by-5. This 40-kHz signal is used directly, or is further divided by 3 in M4, M5, or is divided by 10 in M6, to generate the proper ratio of frequencies for the modulation signal, as selected by the MODULATION FREQUENCY HZ switch. The 4-kHz signal is applied to M8 (divide-by-2), to M9 (divide-by-2), and then to M10 (divide-by-10) to produce a 100-Hz square wave. Circuit M11, M12, and M13 are each divide-by-10 circuits to produce the timing signal of 10 Hz, 1 Hz, and 0.1 Hz, for selection at the three other gates in M1. One of these three timing signals is selected by the COUNTING TIME switch. Three pairs of flip-flops perform the single ac set-ac reset function. These flip-flops, (M14, M15; M16, M17; and M18, M19) are used in a loop to control the timing of the digital counter. Flip-flops M20 and M21 are also used as a single ac set-ac reset flip-flop in conjunction with the

SYNC pushbutton to enable a synchronous start of the various counter circuits.

l. *Time-Delay Logic A9* (fig. 9-26). This module contains divider circuits plus diode AND gates for the eventual generation of the reference timing signal. A square-wave input at pin F is divided by 2 in M1, producing a strobe signal. Circuits M2, M3, and M4 are used together for a divide-by-5, M5 and M6 are used for a divide-by-4, and M7 and M8 are used for a divide-by-4. The outputs of the first counter diode-decoded to generate 1 out of 5 (time 1 through time 5); the outputs of the second and third counter are diode-decoded to generate 1 out of 4. Three outputs, one associated with each counter, are therefore selected at any time. The output at pin R is a square wave of the proper modulating frequency, 250, 83-1/3, or 25 Hz.

m. *Frequency Counter-Display A1* (fig. 9-28). This module contains five numerical indicator tubes plus the driving, counting, and decoding circuitry needed for the digital frequency counting. A sine-wave input is fed to Schmitt trigger Q3, Q4, and then to common-emitter switch Q5, which generates a square wave between ground and +5 volts. This square wave is then enabled during a time determined by the display gate signal to drive five series decade counters M2 through M6. The outputs of these counters are decoded by decoder-drivers M7 through M11 and drive indicator tubes. Diodes CR1 through CR10 are used as clamps so that the integrated circuit outputs cannot get much more positive than + 55 volts. Transistors Q1 and Q2 are used as a voltage source to derive the + 55 volts from the high voltage used by the indicator tubes. Circuit M1 also contains a gate used as a driver for resetting the counter.

n. *+12 and -12 Volt Regulators A11* (fig. 9-30). The +12 volt circuit provides an adjustable, regulated voltage that is also protected against excess output current. If the circuit tries to deliver an excess current, the output voltage will drop near ground. Differential amplifier Q16 and Q18 has one input referenced to Zener diode CR4 and the other input samples the dc output voltage through the tap on resistor R37. The amplifier error voltage at the collector of Q16 is amplified by Q14, then fed to pass transistors Q12 and Q13, which operate as a compound emitter follower. The unregulated voltage is applied to pin T and a higher voltage (approximately +40 volts) is applied to pin S. Transistors Q2 and Q4 compose a differential amplifier for current overload protection. Resistor R6 is the

current-sensing resistor. If the voltage drop across R6 exceeds a level as determined by R15 and R16, Q2 will turn off and Q4 will turn on. Transistor Q8 will also turn on, thereby taking all the current from Q7 which had been supplying the base current for pass transistor Q13. With no more base current, the pass transistors cannot supply any more output current. The operation of the

-12-volt circuit is similar to that of the + 12-volt circuit.

o. *+5-volt Regulator A5* (fig. 9-32). The operation of the + 5-volt circuit is similar to that of the + 12-volt regulator circuit. The 1-ohm, 2.5-watt resistor is the current-sensing component. Zener diodes CR3 and CR4 derive +18 volts at pin C from the higher voltage input at pin A.

## CHAPTER 6

## GENERAL SUPPORT MAINTENANCE

## Section I. GENERAL SUPPORT TROUBLESHOOTING

**Warning.**

When troubleshooting or making repairs in this equipment, be extremely careful. Voltages as high as 230 volts ac and 250 volts dc are present internally when the unit has primary power applied. Use insulated test probes when making voltage measurements. Always disconnect the power cord from the source before touching any components mounted directly to the chassis, or any part of the power supply. If only making measurements or tests on the printed circuit board assemblies, the POWER switch need only be set to the OFF position before touching parts or changing components.

**6-1. General**

a. The first step in troubleshooting the TS-2669/GCM is to localize the fault. Localization means tracing the fault to the defective circuit. For this equipment, a fault must be localized to one of the circuit modules (para 5-7).

b. The second step, isolation, means tracing the fault to the defective part. Some parts, such as burned-out resistors or arcing or shorted transformers, can often be isolated by sight, smell, or sound. The majority of faults, however, must be isolated by checking voltages and resistances.

c. Standard repair procedures (TB SIG 222) should be followed after a trouble has been isolated.

**6-2. Localization Procedures**

a. *General.* Familiarity with the overall operation of the equipment (paras 5-4 and 5-5) and the detailed operation of each individual assembly (para 5-7) is important. Determine the equipment malfunction with the most probably faulty section, or trace the malfunction back to its source. Use figure 9-35 showing typical wave-forms at key points on the modules, to help in the localizing trouble and in troubleshooting. The location of all modules is shown in figure 9-34.

b. *Power Supply.* Check to see whether the power supplies are furnishing the proper voltages under full load. The voltages should be within  $\pm 3$  percent of nominal.

c. *Chassis Components.* With the primary power

disconnected from the unit, check the resistance or continuity of any component suspected of being defective.

**6-3. Isolation Procedures****Caution:**

**This equipment contains transistors and diodes. Be extremely careful when measuring voltages to prevent short circuits. Use tape or sleeving to insulate the entire test prod, except for the extreme tip.**

a. Perform isolation checks after trouble is localized to a specific printed circuit board or subassembly by the use of the foregoing procedures. Use the schematic diagrams and the component location drawings (figs. 9-3 to 9-33) to trace signals, measure voltages, monitor waveforms, and isolate trouble to the faulty part.

b. Semiconductors are a major cause of failure than any other components. Check to see that transistors are passing signals, and that the base and emitter voltages are within approximately 1 volt of each other at all times. Check to see that the resistances of diodes are high in one direction and low in the other. Check to see that capacitors are not short-shorted or open, and that they will pass an ac signal. Replace any component suspected of being defective with a good one, to verify localization of the fault.

c. Use the extender board to facilitate localization. See that all printed circuit boards are seated firmly in their connectors for proper electrical contact. See that all dc voltages and ground are applied to the board.

d. In all tests, the possibility of intermittent troubles should not be overlooked. If present, this type of trouble often may be made to appear by tapping or jarring the equipment.

**Note.**

**Test equipment required for maintenance of the TS-2669/GCM are listed in appendix C of this manual.**

## Section II. REPAIR AND TESTING

### 6-4. Removal and Replacement Procedures

(fig. 9-36)

a. *Removal of Vfo Assembly C4713.* Remove bottom cover from TS-2669/GCM. Loosen but do not remove 12 front panel mounting screws (2). Remove front panel knobs (6). Remove four mounting screws (1). Disconnect both connectors on C2713 and carefully remove assembly from bottom of TS-2669/GCM.

b. *Removal of Frequency Counter-Display Assembly C4625.* Remove top cover from TS-2669/GCM. Disconnect three connectors from C4625. Remove six screws (3). Remove escutcheon (4) and radio-frequency interference (rfi) window (.5) from front panel. Lift C4625 assembly carefully up and out of TS-2669/GCM.

c. *Parts Removal.* Before a part is removed, note the position of the part and its leads. Wire replacement parts in essentially the same position to avoid undesired coupling or other effects. In the case of printed circuit cards, always be sure they are replaced in the proper connector in the original orientation, so that the component side of the board faces the correction direction. Follow the instructions in TB SIG 222 for the correct procedures.

### 6-5. Repair Procedures

a. All components of the printed circuit card have been conformally coated; therefore, it is necessary to peel back the coating before any repairs can be made.

b. Use pencil-type soldering iron with a 40-watt maximum capacity, because the circuitry is transistorized. If the soldering iron is used with ac, use an isolating transformer between the iron and the line. Do not use a soldering gun; damaging voltages can be induced in components.

**Note.**

**Do not replace the conformal coating on the assembly until after it has been tested and determined to be electrically correct.**

c. After a component has been replaced on a printed circuit card, recoat the affected area with an acceptable coating material.

### 6-6. Adjustments After Repair

The following adjustments are to be performed on the

printed wiring assemblies if any component is replaced during repair. These adjustments are to be made before performing the calibration procedure in paragraph 6-7.

a. *2-MHz Oscillator and Amplifier Assembly A4.* Use Oscilloscope AN/USM-182, connected by a low-capacitance probe (10pF) to TP1, adjust L2 and L3 for maximum amplitude at TP1.

b. *2-MHz Modulator-Mixer Assembly A14.* Operate RANGE (KHZ) switch to 50- 600, TRANSMIT FREQUENCY-RECEIVE FREQUENCY switch to TRANSMIT FREQUENCY, CARRIER FREQUENCY control to 100-kHz output frequency, and TRANSMIT LEVEL DBM control fully cw. Using Oscilloscope AN/USM-182 connected to TP1 on the 2-MHz modulator-mixer assembly (A14), adjust L1 and L4 for maximum amplitude at TP1. Using Voltmeter, Electronic ME-30E/U connected to terminal K of A14 (use extender board A19 to facilitate connection to terminals), select R62 to provide a level at terminal K of 0.0775 volt + 1 percent.

c. *200-kHz Modulator-Mixer Assembly A15.* Operate the RANGE (KHZ) switch to .1-50, TRANSMIT FREQUENCY-RECEIVE FREQUENCY switch to TRANSMIT FREQUENCY CARRIER FREQUENCY control to 10 kHz output frequency, and TRANSMIT LEVEL DBM control fully cw. Using Oscilloscope AN/USM-182 connected to TP1 on the 200-kHz modulator-mixer assembly (A15), adjust L1 and L4 for maximum amplitude at TP1. Using Voltmeter, Electronic ME-30E/U connected to terminal L of A15 (use card extender A19 to facilitate connection to terminal), select R62 to provide a level at terminal L of 0.0775 volt  $\pm$ 1 percent.

d. *Low-Pass Active Filter Assembly A13 Only.*

(1) Use card extender A19 to make components on low-pass active filter assembly A13 accessible. Connect probe from channel A of Oscilloscope AN/USM-182 to terminal P of A13 and probe from channel B to terminal Y of A13. Operate MODULATION FREQUENCY HZ switch to 25. Check to see that the waveform on channel A is a square wave and the waveform at channel B is a sine wave. Adjust the AN/USM-182 so that both channels are displayed simultaneously and are ac-coupled. Superimpose the sine-wave pattern on the square-wave pattern so that their



0-volt levels coincide. Select R61 to provide a positive peak of the sine wave that is in phase with the positive-going edge of the square wave.

(2) Operate the MODULATION FREQUENCY HZ switch to 83 1/3 and connect the AN/USM-182 B-channel probe to pin S of A13. Follow the procedure in (1) above for selecting R63.

(3) Operate the MODULATION FREQUENCY HZ switch to 250 and connect the AN/USM-182 B-channel probe to pin K of A13. Follow the procedure in (1) above for selecting R65.

(4) Wrap and solder the selected resistors in place.

e. *Output Amplifier-Meter Amplifier Assembly A12.* Use card extender A19 to make components accessible. Operate RANGE (KHZ) switch to 50-600. Remove assembly A14 from TS-2669/GCM. Connect probe from AN/USM182 to TP3 on A12. Select R70 on A12 to obtain a dc voltage level on TP2 to 0 to +0.1 volt dc. Wrap and solder R70 in place. Replace assembly A14 in TS-2669/GCM.

f. *Input Amplifier-Demodulator Assembly A6.* Use card extender A19 to make components accessible. With no input signal connected to either RECEIVE jack, connect probe from Oscilloscope AN/USM-182 to TP2 of A6. Select R40 to obtain +0.5 volt dc  $\pm 0.2$  volt at TP2. Wrap and solder R40.

**6-7. Calibration**

a. *Initial Conditions.* Allow at least a 20 minute warmup time before any adjustments. Operate the front panel controls as follows:

Switch	Position
RECEIVE IMPEDANCE	600
TRANSMIT IMPEDANCE	600
REF RETURN-END TO END	END TO END
TRANSMIT FREQUENCY-RECEIVE FREQUENCY	TRANSMIT FREQUENCY
MODULATION FREQUENCY HZ	25
COUNTING TIME	1 SEC
SWEEP-CARRIER-REFERENCE	CARRIER
CARRIER FREQUENCY	Set for approximately 10 kHz.
OUTPUT LEVEL DBM	0
RECEIVE LEVEL DBM	0

b. *Power Supply Voltages.* On +12- and -12-volt regulator assembly All, adjust R37 so that the voltage is +12.0 volts dc at pin Y; and adjust R34 so that the voltage is -12.0 volts dc at pin D. On the +5-volt

regulator assembly (A5), adjust R21 so that the voltage is +5.0 volts dc at pin Y.

c. *Output Amplifier Level.* Operate the TRANSMIT LEVEL DBM control fully clockwise. Connect a 600-ohm  $\pm 1$ -percent resistors across the tip and ring terminals of the BAL TRANSMIT jack. Use Voltmeter, Electronic ME30E/U, and adjust R9 on the output amplifier and meter amplifier assembly (A12) to obtain a voltage of 2.45 volts ac at TP1. Adjust R36 on A12 to obtain a voltage of 0.775 volt across the 600-ohm resistor at the BAL TRANSMIT jack. Operate % MOD-RECEIVE LEVELTRANSMIT LEVEL switch TRANSMIT LEVEL. Adjust R16 on A12 to obtain a level reading of 0 dbm on the dbm/% MODULATION meter.

d. *Percent Modulation Calibration.* Operate the % MOD-RECEIVE LEVELTRANSMIT LEVEL switch to % MOD. Monitor the output signal at the BAL TRANSMIT jack with oscilloscope AN/USM-182. Operate the % MON ADJ control to obtain a 50-percent modulated waveform on the AN/USM-182. Adjust R4 on Modulator meter adjust assembly A20 to obtain a reading of 50-percent on the dbm/% MODULATION meter.

e. *Sweep Drive Baseline.* Operate SWEEP TIME control counterclockwise (ccw) toward the 1 SEC position. Operate the SWEEP CALIBRATE switch to LOW CAL. On sweep drive assembly A16, monitor TP1 with Oscilloscope AN/USM-182. Adjust R4 so that the voltage at TP1 does not vary around ground by more than  $\pm 2$  millivolts when the SWEEP WIDTH control is operated from fully ccw to fully cw. Operate the SWEEP CALIBRATE switch to SWEEP and monitor the triangular waveform at TP1 with the AN/USM-182. Adjust R51 on A16 so that the most positive excursion of the triangular waveform is at ground, and note the level of negative excursion. Operate the SWEEP CALIBRATE switch to HIGH CAL. Adjust R52 on A16 so that the dc level at TP1 is the same as noted for the most negative excursion of the triangular waveform  $\pm 3$  millivolts.

f. *Vfo Frequency Calibration.* The adjustments for variable frequency oscillator assembly A2 are located by removing the bottom cover of the TS-2669/GCM. Connect Frequency. Meter AN/TSM-16 to connector XA16 pin T.

(1) Operate SWEEP-CARRIER-REFERENCE switch to CARRIER and CARRIER FREQUENCY control fully ccw. Adjust capacitor C7 on A2 to obtain a reading on the AN/TSM-16 of 200,000 Hz.

(2) Operate SWEEP-CARRIER-REFERENCE switch to REFERENCE and REFERENCE FREQUENCY control fully ccw. Adjust

capacitor C9 on A2 to obtain a reading on the AN/TSM-16 of 200,000 Hz.

(3) Operate SWEEP CALIBRATE switch to SWEEP, CARRIER FREQUENCY control fully ccw, SWEEP WIDTH control fully ccw, and SWEEP CALIBRATE switch to LOW CAL. Adjust C1 on A2 to obtain a reading on the AN/ TSM-16 of 200,000 Hz.

*g. Input Amplifier Gain.* Connect Signal Generator AN/URM-127 to the tip and ring terminals of the BAL RECEIVE jack. Using Voltmeter, Electronic ME-30E/U as a monitor, adjust the AN/URM-127 level, at 1 kHz, to 0.775 volt into the BAL RECEIVE jack. Operate the % MOD-RECEIVE LEVEL-TRANSMIT LEVEL switch to RECEIVE LEVEL. Adjust R9 on input amplifier-demodulator assembly A6 to obtain a reading of 0 on the dbm/% MODULATION meter.

*h. Delay Meter Scaling.*

(1) Connect a jumper cable between the BAL TRANSMIT and BAL RECEIVE jacks.

(2) Operate MODULATION FREQUENCY HZ switch to 25 and % MOD-RECEIVE LEVEL-TRANSMIT LEVEL switch to % MOD.

(3) Operate % MOD ADJ control to obtain indication of 45-50 on dbm/% MODULATION meter.

(4) Operate % MOD-RECEIVE LEVEL-TRANSMIT LEVEL switch, to RECEIVE LEVEL and RECEIVE LEVEL DBM switch to obtain dbm/ % MODULATION meter indication between -10 and 0.

(5) Operate DELAY METER RANGE MS switch to 3--10 and COARSE DELAY MS switch to 0-10.

(6) Operate DELAY ZERO ADJ control until DELAY meter reads 0 (black 0-10 scale).

(7) Operate COARSE DELAY MS switch to 30-40 and on delay output assembly A8, adjust R55

until DELAY meter reads 10 (full scale).

(8) Repeat the procedures in (5), (6), and (7) above until no further adjustment is required.

(9) Operate DELAY METER RANGE MS switch to .5-.5, COARSE DELAY MS switch to 0-10, FINE DELAY MS switch to 0.5, and adjust DELAY ZERO ADJ control until DELAY meter reads 0 (black 0-.5 scale).

(10) Operate FINE DELAY MS switch to 0, and adjust R52 on delay output assembly A8 until DELAY meter reads .5 (full scale).

(11) Repeat the procedures in (9) and (10) above until no further adjustment is required.

*i. Receive Level Variation.* Perform the procedure in g(1), (2), (3), and (4) above. Operate TRANSMIT LEVEL DBM control fully cw. Operate MODULATION FREQUENCY HZ switch to 250. Operate DELAY METER RANGE MS switch to .15-.5. Operate COARSE DELAY MS switch, FINE DELAY MS switch, and DELAY ZERO ADJ control until DELAY meter reads near center scale. Note this position. Operate the TRANSMIT LEVEL DBM control (operate the TRANSMIT LEVEL DBM switch, also if needed) until the indication is -6 on the dbm/% MODULATION meter. Note the reading on the DELAY meter. If a change of 1/2 of a division or more occurred, adjust R68 on delay output assembly A8 so a difference in receive level of 6 db will cause less than 1/2 a division change in the DELAY meter indication. A similar procedure is used for the other two modulating frequencies. For the different modulation frequencies, adjust the following resistors:

Mod freq (Hs)	Resistor
250	R68
83 1/3	R59
25	R58

**6-8. Final Test Procedures**

Step	Condition	Requirement
1	Make sure the internal power supply connections are set for the proper primary supply voltage (fig. 2-2 and 9-86).	
2	Operate SWEEP-CARRIER-REFERENCE switch to CARRIER. Operate RANGE (KHZ) switch and CARRIER FREQUENCY control to vary the frequency. Monitor frequency on FREQUENCY display.	Frequency range should be at least 100 Hz to 552 kHz.
3	Operate SWEEP-CARRIER-REFERENCE switch to REFERENCE. Operate RANGE (KHZ) switch and REFERENCE FREQUENCY control to vary frequency. Monitor frequency on the FREQUENCY display.	Same as step 2.

Step	Condition	Requirement
4	Use Frequency Meter AN/TSM-16 to measure the frequency of the square wave at pin R of delay logic assembly A9; operate MODULATION FREQUENCY HZ switch to 25.	AN/TSM-16 should read 25 Hz.
5	Operate the MODULATION FREQUENCY HZ switch to 83-1/3.	AN/TSM-6 should read 83-1/3 Hz.
6	Operate the MODULATION FREQUENCY HZ switch to 250.	AN/TSM-16 should read 250 Hz.
7	Operate the SWEEP TIME control to 1 SEC. Adjust SWEEP WIDTH control so that the most negative voltage at TP1 of sweep drive assembly A16 is approximately -9 to -10 volts. Note the time it takes for the signal at TP1 to go from the most negative to the most positive voltage.	The observed time should be about 1 second or less.
8	Operate the SWEEP TIME control to 2 MIN. Note the time it takes for the signal at TP1 of sweep drive assembly A16 to go from the most negative to the most positive voltage.	The observed time should be 2 minutes or more.
9	Operate the RANGE (KHZ) switch to .1 -50. Set a carrier frequency of approximately 5 kHz. Operate the SWEEP-CARRIER REFERENCE switch to SWEEP, SWEEP CALIBRATE switch to SWEEP, SWEEP WIDTH control to .3 KHZ, and SWEEP TIME control to a convenient setting for observation. Monitor the range of the sweep frequency on the FREQUENCY display.	Frequency range should be less than 300 Hz.
10	Operate the SWEEP WIDTH control to 12.5 KHz. Monitor the range of the sweep frequency on the FREQUENCY display.	Frequency range should be more than 12.5 kHz.
11	Operate the SWEEP-CARRIER-REFERENCE switch to CARRIER, and COUNTING TIME switch to 10 SEC. Check to see that the number in the FREQUENCY display is about 50000. Operate COUNTING TIME switch to 1 SEC.	Number in FREQUENCY display should be 1/10th $\pm$ 1 digit of previous display.
12	Operate COUNTING TIME switch to .1 SEC.	Number should be 1/10th $\pm$ 1 digit of setting in 1 SEC position.
13	Turn % MOD ADJ fully clockwise, then fully counterclockwise. Note the percent modulation reading on the dbm/% MODULATION meter and monitor either TRANSMIT jack output signal with Oscilloscope AN/USM-182.	Dbm/% MODULATION meter should read between 0 and at least 50. AN/USM-182 should show carrier signal with 50-percent modulation.
14	Connect leads of Multimeter AN/USM-223 between rear panel analog delay output terminal (fig. 3-2) and ground. Set up controls and jumper cable (para 4-4, 11ac, ae). Operate DELAY METER RANGE MS switch to .15 - .5, COARSE DELAY MS to 0, and FINE DELAY MS to 0. a. Operate DELAY ZERO ADJ control to obtain DELAY meter indication of 0 (black 0 - .5 scale). b. Operate DELAY ZERO ADJ control slowly cw until DELAY meter indication is .5 (Black 0 - .5 scale).	a. AN/USM-223 will read approximately -0.05 volt. b. AN/USM-223 will read approximately +0.05 volt.

- | Step | Condition   | Requirement   |
|------|---|---|
| 15   | Connect leads of AN/USM-223 between rear panel analog frequency output terminal (fig. 3-2) and ground. Operate TRANSMIT FREQUENCY-RECEIVER-FREQUENCY switch to TRANSMIT FREQUENCY and SWEEP CARRIER-REFERENCE switch to CARRIER. Operate CARRIER FREQUENCY control and RANGE (KHZ) switch to vary output carrier frequency from 0.100 KHz to 552 kHz as monitored on the FREQUENCY display. | Dc level on AN/USM-223 will vary from 1 to approximately 5 volts      |
| 16   | Connect leads of AN/USM-223 between rear panel analog amplitude terminal (fig. 3-2) and ground. Operate % MOD-RECEIVE LEVEL TRANSMIT LEVEL switch to TRANSMIT LEVEL, RANGE (KHZ) switch to .1 -50, and operate CARRIER FREQUENCY control to obtain an indication of 1,000 Hz on the FREQUENCY display. Operate the TRANSMIT LEVEL DBM control from fully cw to fully ccw.                   | DC level on AN/USM-223 will vary from 0.5 to approximately 2.3 volts. |

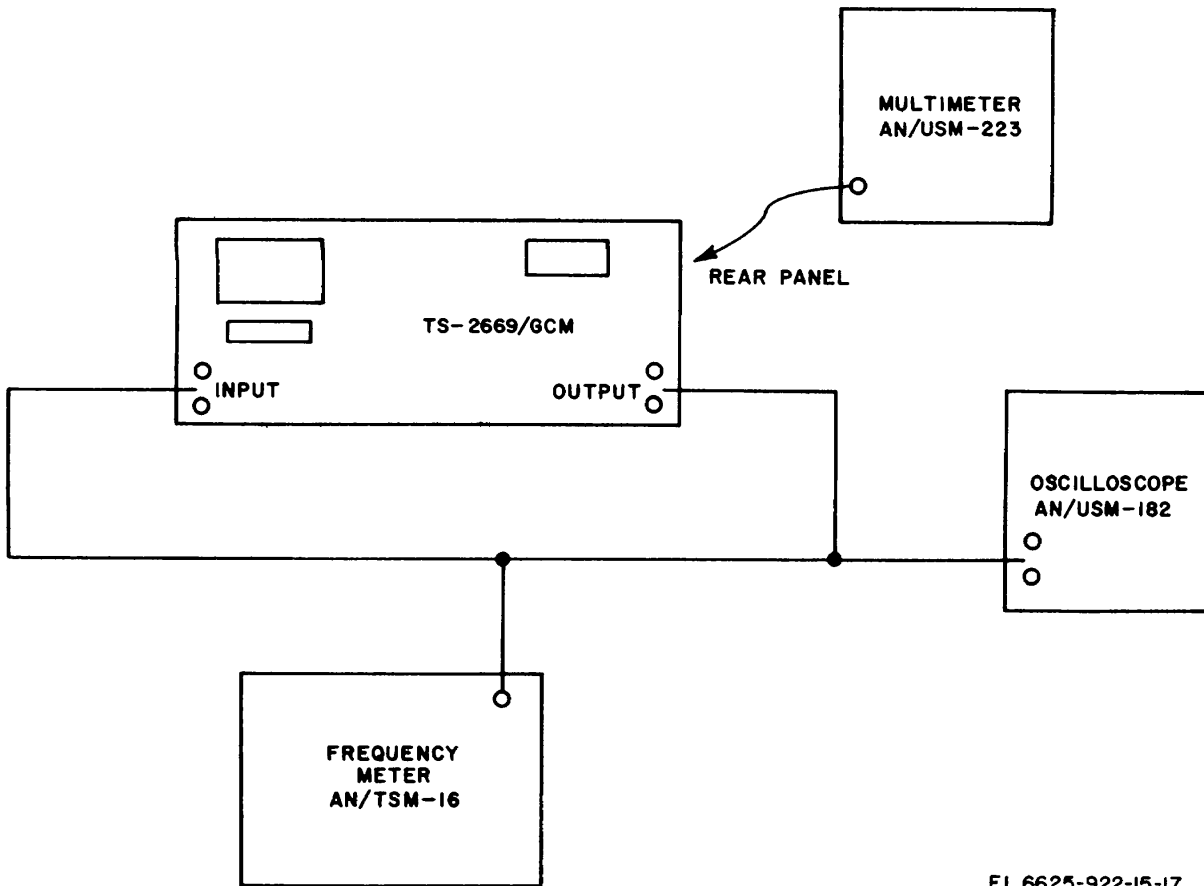

EL 6625-922-15-17

Figure 6-1. Test setup.

## CHAPTER 7 DEPOT OVERHAUL STANDARDS

---

### 7-1. Applicability of Depot Overhaul Standards

The tests outlined for this chapter are designed to measure the performance capability of an equipment to be stocked or returned to the user. Equipment that meets the minimum standards stated in the tests will have performance capability equivalent to new equipment.

### 7-2. Applicable References

*a. Repair Standards.* Applicable procedures for the depot performing this test and its general standards for repaired equipment form a part of the requirements for testing this equipment.

*b. Technical publications.* Refer to appendix A for applicable publications applying to this equipment.

*c. Modification Work Orders.* Perform all applicable modification work orders pertaining to the equipment before making the specified tests. DA Pam 310-7 lists all current MWO's.

### 7-3. Test Facilities Required

The test facilities required are identical with those required for general support testing. Refer to the requirements of paragraph 6-8 for the test equipment and materials required.

### 7-4. Test Procedures

Perform the general support test procedures (para 6-8). Acceptable standards for depot overhaul are the same as those for general support testing.

**CHAPTER 8**  
**SHIPMENT, LIMITED STORAGE, AND DEMOLITION**  
**TO PREVENT ENEMY USE**

---

**Section I. SHIPMENT AND LIMITED STORAGE**

**8-1. Disassembly of Equipment**

Perform the following procedure to disassembly the TS-2669/GCM.

- a. Turn the POWER switch to OFF.
- b. Disconnect the power and signal wires.
- c. If the unit is in a rack, unscrew the bolts, and remove it from the rack.

**8-2. Repackaging for Shipment or Limited Storage**

Repackaging the TS-2669/GCM for shipment or limited storage normally will be performed at a packaging facility or by a packaging team. If emergency packaging is required, select materials from those listed in SB 38-100. Package the TS2669/GSM in accordance with the original packaging (fig. 2-1) as far as possible with available materials.

**Section II. DEMOLITION OF MATERIEL TO PREVENT ENEMY USE**

**8-3. Authority for Demolition**

Demolition of the equipment will be accomplished only upon the order of the commander. The destruction procedures outlined in paragraph 8-4 will be used to prevent further use of the equipment.

**8-4. Methods of Destruction**

Use any of the following methods to destroy the equipment.

- a. *Smash.* Smash the controls, transistors, switches, resistors, capacitors, transformers, and the printed circuit boards.

- b. *Cut.* Cut the power cable, cut the input and output cables, and slash the connecting wiring to the front panel.

- c. *Burn.* Burn cables and instruction manuals.

- d. *Bend.* Bend panel and chassis.

**Warning: Be extremely careful with explosives and incendiary devices. Use these items only when the need is urgent.**

- e. *Explode.* Explode only if necessary.

- f. *Dispose.* Bury or scatter the destroyed parts in slit trenches or foxholes, or throw into streams.

## CHAPTER 9 ILLUSTRATIONS

### 9-1. General

This chapter lists the illustrations in the rear of the manual. The illustrations are numbered in sequence as being part of this chapter. The sequence of illustrations follows that of the text.

### 9-2. List of Illustrations

The illustrations that are part of this chapter and found in the rear of the manual are as follows:

Fig. No.	Caption	Fig. No.	Caption
9-1	Complete schematic diagram (transmit)	9-19	Output amplifier and meter amplifier (A12), C-4704, location of components
9-2	Complete schematic diagram (receive)	9-20	Analog output (A3), C-4801, schematic diagram
9-3	2-MHz oscillator (A4), C-4696, schematic diagram	9-21	Analog output (A3), C-4801, location of components
9-4	2-MHz oscillator (A4), C-4696, location of components	9-22	Delay output (A8), C-4700, schematic diagram
9-5	Variable-frequency oscillator (A2), D-4710, schematic diagram	9-23	Delay output (A8), C-4700, location of components
9-6	Variable-frequency oscillator (A2), D-4710, location of components	9-24	Countdown logic (A10), C-4702, schematic diagram
9-7	Sweep drive (A16), C-4707, schematic diagram	9-25	Countdown logic (A10), C-4702, location of components
9-8	Sweep drive (A16), C-4704, location of components	9-26	Time delay logic (A19), C-4701, schematic diagram
9-9	2-MHz modulator mixer (A14), C-4706, schematic diagram	9-27	Time delay logic (A9), C-4701, location of components
9-10	2-MHz modulator mixer (A14), C-47065, location of components	9-28	Frequency counter/display (A1), D-4637, schematic diagram
9-11	200-kHz modulator mixer (A15), C-4706, schematic diagram	9-29	Frequency counter/display (A1), D-4637, location of components
9-12	200-kHz modulator mixer (A15), C-4706, location of components	9-30	+ 12- and -12-volt regulators (A11), C-4703, schematic diagram
9-13	Low-pass active filters (A7, A13), C-4699-1, C-4699-2, schematic diagram	9-31	+ 12- and -12-volt regulators (A11), C-4703, location of components
9-14	Low-pass active filter (A7), C-4699-1, location of components	9-32	+5-volt regulator (A5), C-4697 &, schematic diagram
9-15	Low-pass active filter (A13), C-4699-2, location of components	9-33	+ 6-volt regulator (A5), C-4697, location of components
9-16	Input amplifier and demodulator (A6), C-4698, schematic diagram	9-34	Location of assemblies
9-17	Input amplifier and demodulator (A6), C-4698, location of components	9-35	Signal waveforms
9-18	Output amplifier and meter amplifier (A12), C-4704, schematic diagram	9-36	Assembly drawing
		9-37	Transmit impedance selector and attenuator (A17), B-4715, schematic diagram
		9-38	Transmit impedance selector and attenuator (A17), B-4715, location of components
		9-39	Receive impedance selector and attenuator (A18), C-4714, schematic diagram
		9-40	Receive impedance selector and attenuator (A18), C-4714, location of components
		9-41	Meter modulation adjust (A20), B-4806, schematic diagram
		9-42	Meter modulation adjust (A20), B-4806, location of components
		9-43	Extender board assembly (A19), C-4695

## APPENDIX A REFERENCES

---

Following is a list of references applicable to the TS-2669/GCM.

DA Pam 310-4	Index of Technical Manuals, Technical Bulletins, Supply Manuals (Types 7, 8, and 9), Supply Bulletins, and Lubrication Orders.
DA Pam 310-7	U. S. Army Equipment Index of Modification Work Orders.
SB 38-100	Preservation, Packaging, Packing, and Marking Materials, Supplies, and Equipment Used by the Army.
TB SIG 222	Solder and Soldering.
TM 11-6625-203-12	Operator and Organizational Maintenance: Multimeter AN/URM-105, Including Multimeter ME-77/U.
TM 11-6625-218-12	Organizational Maintenance Manual: Frequency Meter AN/TSM-16.
TM 11-6625-320-12	Operator and Organizational Maintenance Manual: Voltmeter, Meter ME-30A/U and Voltmeters, Electronic ME-30B/U, ME-30C/U, and ME-30E/U.
TM 11-6625-555-12P	Operator and Organizational Maintenance Repair Parts and Special Tool Lists and Maintenance Allocation Chart: Oscilloscope AN/USM-182.
TM 11-6625-683-15	Operator, Organizational, Direct Support, General Support, and Depot Maintenance Manual: Signal General AN/URM-127.
TM 38-750	Army Equipment Record Procedures.
TM 11-5815-343-15	Operator, Organizational, DS, GS, and Depot Maintenance Manual, Including Repair Parts and Special Tool Lists: Equalizer, Envelope Delay and Amplitude CN-1234/GCC.



**APPENDIX B  
BASIC ISSUE ITEMS**

**Section I. INTRODUCTION**

**B-1. Scope**

This appendix lists items comprising an operable equipment and those required for installation, operation, or operator's maintenance for Measuring Set, Envelope Delay Distortion TS-2669/GCM.

**B-2. Explanation of Columns**

The following is a list of explanations of columns in section II.

*a. Source, Maintenance, and Recoverability Codes (SMR) Column.*

(1) *Source code (S).* The selection status and source for the listed item is the first code indicated in this column. The source codes used and their explanations are:

Code	Explanation
P---	Applies to repair parts that are stocked in or supplied from GSA/DSA, or Army supply system, and authorized for use at indicated maintenance categories.
G---	Applies to major assemblies that are procured with PEMA funds for initial issue only to be used as exchange assemblies at DSU and GSU category. These assemblies will not be stocked above DSU and GSU category or returned to depot supply category.

(2) *Maintenance code (M).* The lowest category of maintenance authorized to install the item is indicated by the second code in the column. The maintenance category code and its explanation is:

Code	Explanation
O	Organizational Maintenance

(3) *Recoverability Code (R).* The recoverability code is the third code in the column. It indicates whether unserviceable items should be returned for recovery or salvage. Recoverability code and its explanation is as follows:

*Note.* When no code is indicated in the recoverability column, the part will be considered expendable.

Code	Explanation
R-----	Applies to repair parts and assemblies that are economically repairable at DSU and GSU activities and are normally furnished by supply on an exchange basis.

*b. Federal Stock Number Column.* This column indicates the Federal stock number for the item.

*c. Description Column.* This column includes the Federal item name and any additional description of the item which may be required. A part number or other reference number is followed by the applicable five-digit Federal Supply Code for Manufacturers. Usable on code column is not used.

*d. Unit of Measure Column.* The unit used as a basis of measure (e.g., ea, pr, ft, yd, etc.) is given in this column.

*e. Quantity Incorporated in Unit Column.* The total quantity of the item used in the equipment is given in this column.

*f. Quantity Furnished with Equipment Column.* This column lists the quantity of the item supplied for initial operation of the equipment and/or the quantities authorized to be kept on hand by the operator for maintenance of the equipment.

*g. Illustrations Column.*

(1) *Figure number (a).* The number of the illustration on which the item is shown is indicated in this column.

(2) *Item No. or reference designation (b).* The reference designation and/or item number callout used to reference the item on the illustration appears in this column.

**SECTION II BASIC ISSUE ITEMS**

(1) SMR Code	(2) Federal Stock Number	(3) Description	(4) Unit of meas	(5) Qty inc in unit	(6) Qty furn with equip	(7) Illustration	
						(a) Fig No.	(b) Item No.
G-O-R	6625-880-1578	MEASURING SET, ENVELOPE DELAY DISTORTION TS-2669/GCM: (This item is nonexpendable)				3-1	
		TECHNICAL MANUAL TM11-6625-922-15 Requisition through pinpoint account number if assigned; otherwise through nearest adjutant General Facility. (A quantity of one Technical Manual is packed with each equipment. Where a valid need exists, additional copies may be requisitioned and kept on hand.)	ea	1	1		
P-O		FUSE, CARTRIDGE: MS90078-24-1; 96906	ea	1	5	9-36	F1
P-O		LENS INDICATOR LIGHT: 222-0111-202; 72619	ea	1	1		
P-O	6240-223-9100	LAMP, NEON: NE-5; 81349	ea	1	1		DS1
		ACCESSORIES, TOOLS, AND TEST EQUIPMENT					
P-O		CARD PULLER: 1731; 78769	ea	1	1		
P-O		TOOL, COIL TUNING: 2033-1; 71279	ea	1	1		
		No Basic Issue Items are Mounted in or on the Equipment					

**APPENDIX C  
MAINTENANCE ALLOCATION**

**Section I. INTRODUCTION**

**C-1. General**

This appendix provides a summary of the maintenance operations covered in the equipment literature for Measuring Set, Envelope Delay Distortion TS-2669/GCM. It authorizes categories of maintenance for specific maintenance functions on repairable items and components and the tools and equipment required to perform each function. This appendix may be used as an aid in planning maintenance operations.

Code	Maintenance category
C	Operator/Crew
O	Organizational Maintenance
F	Direct Support Maintenance
H	General Support Maintenance
D	Depot Maintenance

*d. Tools and Equipment.* The numbers appearing in this column refer to specific tools and equipment which are identified by these numbers in section III.

*e. Remarks.* Self explanatory.

**C-2. Explanation of Format for Maintenance Allocation Chart**

*a. Group Number.* Group numbers correspond to the reference designation prefix assigned in accordance with ASA Y32.16, Electrical and Electronics Reference Designations. They indicate the relation of listed items to the next higher assembly.

*b. Component Assembly Nomenclature.* This column lists the item names of component units, assemblies, subassemblies, and modules on which maintenance is authorized.

*c. Maintenance Function.* This column indicates the maintenance category at which performance of the specific maintenance function is authorized. Authorization to perform a function at any category also includes authorization to perform that function at higher categories. The codes used represent the various maintenance categories as follows:

**C-3. Explanation of Format for Tool and Test Equipment Requirements**

The columns in the tool and test equipment requirements chart are as follows:

*a. Tools and Equipment.* The numbers in this column coincide with the numbers used in the tool and equipment column of the MAC. The numbers indicate the applicable tool for the maintenance function.

*b. Maintenance Category.* The codes in this column indicate the maintenance category normally allocated the facility.

*c. Nomenclature.* This column lists tools, test, and maintenance equipment required to perform the maintenance functions.

*d. Federal Stock Number.* This column lists the Federal stock number.

*e. Tool Number.* Not used.

**Section II.**

**MAINTENANCE ALLOCATION CHART  
MAINTENANCE FUNCTIONS**

GROUP NUMBER	COMPONENT ASSEMBLY NOMENCLATURE	MAINTENANCE FUNCTIONS											TOOLS AND EQUIPMENT	REMARKS	
		I N S P E C T	T E S T	S E R V I C E	A D J U S T	A L I G N	C A L I B R A T E	I N S T A L L	R E P L A C E	R E P A I R	O V E R H A U L	R E B U I L D			
1A	MEASURING SET, ENVELOPE	C													External
	DELAY DISTORTION	O											8	Internal	
	TS-2669/GCM		O										3	Continuity tests	
			H										2,3,4,5,6,9	All tests	
						H							2,3,5,8,11		
							H						2,3,5,8,11		
	PRINTED CIRCUIT		O										8	Replace knobs, lamps, fuse and printed circuit card	
	CARD ASSEMBLIES		H										7	All repairs	
													7		
													3	Continuity, tests	
													1,2,3,4,5,6,9	All tests	
													10		
									0				8		
										H			7		

**TS-2669/GCM**

**SECTION III**

<b>TOOL AND TEST EQUIPMENT REQUIREMENTS</b>				
<b>TOOL OR TEST EQUIPMENT</b>	<b>MAINTENANCE CATEGORY</b>	<b>NOMENCLATURE</b>	<b>FEDERAL STOCK NUMBER</b>	<b>TOOL NUMBERS</b>
1	H,D	MEASURING SET, ENVELOPE DELAY DISTORTION TS 2669/GCM	6625-880-1578	
2	H,D	FREQUENCY METER, AN/TSM-16	6625-542-1666	
3	H,D	GENERATOR, SIGNAL AN/URM-127	6625-783-5965	
4	O,H,D	MULTIMETER, AN/USM-223 (Use AN/URM-105 and TS-352/U until AN/USM-223 is available.)	6625-999-7465	
5	H,D	OSCILLOSCOPE, AN/USM-182	6625-952-3979	
6	H,D	TEST SET, SEMICONDUCTOR DEVICE, TS-1836/U	6625-893-2628	
7	H,D	TOOL KIT, ELECTRONIC EQUIP, TK-100/G	5180-605-0079	
8	0	TOOL KIT, ELECTRONIC EQUIP, TK-105/G	5180-610-8177	
9	H,D	VOLTMETER, ELECTRONIC ME-30E/U	6625-669-0742	
10	H,D	CARD EXTENDER (Tool included as part of end item.)		
11	H,D	COIL TUNING TOOL  (Tool included as part of end item.)		

**TS-2669/GCM**

**APPENDIX D  
ORGANIZATIONAL, DS, GS, AND DEPOT REPAIR PARTS**

**Section I. INTRODUCTION**

**D-1. Scope**

This appendix contains a list of repair parts required for the performance of organizational maintenance and a list covering the corresponding requirements for general support and depot maintenance for Measuring Set, Envelope Delay Distortion TS-2669/GCM.

*Notes:*

1. No parts authorized for stockage at direct support.
2. No special tools, test, and support equipment are required.

**D-2. General**

The repair parts list is divided into the following sections:

*a. Prescribed Load Allowance (PLA), Section II.* The PLA is a consolidated listing of repair parts allocated for initial stockage at the organizational maintenance category. This is a mandatory minimum stockage allowance.

*b. Repair Parts for Organizational Maintenance, Section III.* Repair parts authorized for organizational maintenance are included in this section.

*c. Repair Parts for Direct Support, General Support, and Depot Maintenance, Section IV.* Repair parts authorized for general support and depot maintenance are included in this section. No parts authorized for stockage at direct support.

*Note.* All indexes noted below are cross referenced to index numbers. The index numbers appear in ascending sequence in column 1 of the repair parts list (para D3a). The index number for the particular item will be the same for the item in all sections of this appendix.

*d. Federal Stock Number Cross Reference to Index Number, Section V.* This is a cross reference index of Federal stock numbers to index numbers.

*e. Figure and Item Number Cross Reference to Index Number, Section VI.* This is a cross reference index of figure number and item number (or reference designation) to index number. The figure numbers are listed in numerical sequence; item numbers and/or reference designations are listed for each figure.

*f. Reference Designation Cross Reference to Index Number, Section VII.* This is a cross reference

index of reference designations and/or item numbers to index numbers.

**D-3. Explanation of Columns**

An explanation of the columns is given below.

*a. Source, Maintenance, and Recoverability Codes (SMR) and Index Numbers Column.* The first line in this column lists the applicable SMR codes for the part. Listed in ascending order directly below the SMR codes is the index number assigned to the repair part.

(1) *Source code (S).* The selection status and source for the listed item is noted here. Source codes and their explanations are as follows:

Code	Explanation
<i>P</i> ---	Applies to repair parts that are stocked in or supplied from the GSA/DSA, or Army supply system, and authorized for use at indicated maintenance categories.
<i>M</i> ---	Applies to repair parts -that are not procured or stocked but are to be manufactured at indicated maintenance categories.
<i>A</i> ---	Applies to assemblies that are not procured or stocked as such but are made up of two or more units, each of which carries an individual stock number and description and is procured and stocked and can be assembled by units at indicated maintenance categories.
<i>X1</i> ---	Applies to repair parts that are not procured or stocked, the requirement for which will be supplied by the use of next higher assembly or component.
<i>X2</i> ---	Applies to repair parts that are not stocked. The indicated maintenance category requiring such repair parts will attempt to obtain them through cannibalization; if not obtainable through cannibalization, such repair parts will be requisitioned with supporting justification through normal supply channels.

Code	Explanation
G-----	Applies to major assemblies that are procured with PEMA funds for initial issue only to be used as exchange assemblies at DSU and GSU category.

(2) *Maintenance code (M)*. The lowest category of maintenance authorized to install the listed item is noted here.

Code	Explanation
O	Organizational Maintenance
H	General Support Maintenance
D	Depot Maintenance

(3) *Recoverability code (R)*. The information in this column indicates whether unserviceable items should be returned for recovery or salvage. Recoverability code and its explanation is as follows:

*Note.* When no code is indicated in the recoverability column, the part will be considered expendable.

Code	Explanation
R-----	Applies to repair parts and assemblies which are economically repairable at DSU and GSU activities and normally are furnished by supply on an exchange basis.

*b. Federal Stock Number Column.* The Federal stock number for the item is listed in this column.

*c. Description Column.* This column includes the Federal-item name and any additional description of the item required, the manufacturer's part number (reference number), and the applicable five-digit Federal Supply Code for Manufacturers. (para D-5). For subsequent appearances of the same item, the manufacturer's code and part number (reference number) are omitted. The words "same as" followed by the index number assigned to the item when it first appeared in the list will follow the item name, e.g., "RESISTOR, FIXED, COMPOSITION: SAME AS A298". Usable on code column is not used.

*d. Unit of Measure Column.* The unit used as a basis of measure (e.g., ea, pr, ft, yd, etc.) is indicated in this column.

*e. Quantity Incorporated in Unit Column.* The quantity of repair parts in an assembly is given in this column.

*f. Maintenance Allowances Column.*

(1) The maintenance allowance columns are divided into subcolumns. Indicated in each subcolumn opposite the first appearance of the item is the total quantity of items authorized for the number of equipments supported. Subsequent appearances of the same item will have no entry in the allowance columns, but will have a reference in the description column to the first appearance of the item. Items authorized for use as required, but not for initial stockage, are identified with an asterisk (\*) in the allowance column.

(2) The quantitative allowances for organizational category of maintenance represents one initial prescribed load for a 15-day period for the number of equipments supported. Units and organizations authorized additional prescribed loads will multiply the number of prescribed loads authorized by the quantity of repair parts reflected in the appropriate density column to obtain the total quantity of repair parts authorized.

(3) Subsequent changes to organizational allowances will be limited as follows: No change in the range of items is authorized. If additional items are considered necessary, recommendations should be forwarded to Commanding General, U.S. Army Electronics Command, ATTN: AMSEL-ME-NMP-CW, Fort Monmouth, N. J. 07703, for exception or revision to the allowance list. Revisions to the range of items authorized will be made by the USA ECOM National Maintenance Point based upon engineering experience, demand data, or TAERS information.

(4) The quantitative allowances for GS category of maintenance will represent initial stockage for a 30-day period for the number of equipments supported.

*g. One-Year Allowances Per 100 Equipments/Contingency Planning Purposes Column.* Opposite the first appearance of each item, the total quantity required for distribution and contingency planning purposes is indicated. The range of items indicates total quantities of all authorized items required to provide for adequate support of 100 equipments for one year.

*h. Depot Maintenance Allowance Per 100 Equipments Column.* This column indicates the total quantity of each item authorized depot maintenance for 100 equipments. Subsequent appearances of the same item will have no entry in this column, but will have a reference in the description column to the first appearance of the item.

*i. Illustrations Column.*

(1) *Figure number (a)*. The number of the illustration in which the item is shown is indicated in this column.

(2) *Item No. or reference designation (b)*. The callout number or reference designation used to reference the item in the illustration appears in this column.

#### D-4. Location of Repair Parts

*a.* This appendix contains three cross-reference indexes (sees V, VI, and VII), to be used to locate a repair part when either the Federal stock number, reference number (manufacturer's part number), figure number, or reference designation is known. The first column in each cross-reference index is prepared,

as applicable, in numerical or alphanumerical sequence. The last column of each cross-reference index lists the index number assigned to the part.

b. Refer to the appropriate cross-reference index (para D-2d, e, and f) and note the index number in the last column; then refer to the repair parts list to locate the index number which is listed in ascending order in column 1 of the repair parts list.

**D-5. Federal Supply Codes**

This paragraph lists the Federal supply code and the associated manufacturer's name.

Code	Manufacturer name
00656.....	Aerovox Corp.
01295.....	Texas Instruments Inc. Semiconductor-Components Division
02660.....	Amphenol Corp.
03860.....	Acton Laboratories Inc.
04713.....	Motorola Semiconductor Products Inc.

Code.....	Manufacturers name
13103.....	Thermalloy Co.
42498.....	National Radio Co. Inc.
56289.....	Sprague Electric Co.
71279.....	Cambridge Thermionic Corp.
72619.....	Dialight Corp.
73899.....	J. F. D. Electronics Co, A Division of Stratford Retreat House
75382.....	Kulka Electric Corp
75915.....	Littlefuse Fuse Inc.
78769.....	E. H. Titchener and Co.
80205.....	National Aerospace Standards Committee Aeronautical Industries Association of America
80294.....	Bourns Inc.
81349.....	Military Specifications
82726.....	Witco Chemical Co. Inc.
83330.....	Herman H. Smith Inc.
83594.....	Burroughs Corp, Electronic Components Division
84411.....	TRW Capacitor Division
89665.....	United Transformer Co.
91506.....	Augat Inc.
96906.....	Military Standards



**SECTION II PRESCRIBED LOAD ALLOWANCE**

(1) Federal stock number	(2) Description  usable on code	(3) 15-Day Org Maint. Allowance			
		(A) 1-5	(B) 6-20	(C) 21-50	(D) 51-100
6240-223-9100	LAMP, NEON: NE-51; 81349	*	*	2	2
6625-717-7458	CIRCUIT CARD ASSEMBLY: C4707; 03860	*	2	2	3
6625-717-7461	CIRCUIT CARD ASSEMBLY: C4706; 03860	*	2	2	3
6625-764-8509	CIRCUIT CARD ASSEMBLY: C4699-2; 03860	*	2	2	3
6625-771-0224	CIRCUIT CARD ASSEMBLY: C4701; 03860	*	*	2	2
6625-771-0229	CIRCUIT CARD ASSEMBLY: C4700; 03860	*	2	2	3
6625-771-0230	CIRCUIT CARD ASSEMBLY: C4702; 03860	*	*	2	2
6625-771-0615	CIRCUIT CARD ASSEMBLY: C4697; 03860	*	*	2	2
6625-771-0641	CIRCUIT CARD ASSEMBLY: C4699-1; 03860	*	2	2	3
6625-771-0651	CIRCUIT, CARD ASSEMBLY: C4696; 03860	*	2	2	3
6625-771-0654	CIRCUIT CARD ASSEMBLY: C4703; 03860	*	2	2	3
6625-771-0666	CIRCUIT CARD ASSEMBLY: C4705; 03860	*	2	2	3
6625-771-0848	CIRCUIT CARD ASSEMBLY: B4714; 03860	*	*	2	2
6625-771-0849	CIRCUIT CARD ASSEMBLY: C4801; 03860	*	2	2	3
6625-771-0855	CIRCUIT CARD ASSEMBLY: B4715; 03860	*	*	2	2
6625-771-0860	CIRCUIT CARD ASSEMBLY: C4698; 03860	*	2	2	3
6625-771-0863	CIRCUIT CARD ASSEMBLY: C4704; 03860	*	2	2	3
6625-922-2673	CIRCUIT CARD ASSEMBLY: C4695; 03860	*	*	2	2
	FUSE, CARTRIDGE: MS90078-24-1; 96906	2	3	7	13
	LENS INDICATOR LIGHT: 222-0111-202; 72619	*	*	2	2



**SECTION IV REPAIR PARTS FOR DIRECT SUPPORT, GENERAL SUPPORT, AND DEPOT MAINTENANCE**

(1) SMR CODE	(2) FEDERAL STOCK NUMBER	(3) DESCRIPTION  USABLE ON CODE	(4) UNIT OF MEAS	(5) QTY INC IN UNIT	(6) 30 DAY DS MAINT ALLOWANCE			(7) 30 DAY GS MAINT ALLOWANCE			(8) 1-YR ALW PER EQUIP CNTGY	(9) DEPOT MAINT ALW PER 100 EQUIP	(10) ILLUS- TRATION	
					(a)	(b)	(c)	(a)	(b)	(c)			(a)	(b)
					1-20	21-50	51-100	1-20	21-50	51-100			FIG. NO.	ITEM NO./ REF DES
G-O-R A001	6625-880-1578	MEASURING SET, ENVELOPE DELAY DISTORTION; TS-2669/GCM: J4691; 03860 (This item is nonexpendable)												
A-H-R A002		FRONT PANEL ASSEMBLY: E4688; 03860	ea	1										
X2-H A003		FRONT PANEL: D4647; 03860	ea	1										
P-H A004		SWITCH, ROTARY: B4665; 03860	ea	1			*	*	2	8	3	9-36	S7	
P-H A005	5930-655-1515	SWITCH, TOGGLE: M635058-23; 96906	ea	2			*	2	2	13	6	9-36	S4, S10	
A-H A006		COUNTER, DISPLAY ASSEMBLY: C4637; 03860	ea	1								9-36		
P-H A007		WINDOW: B4628; 03860	ea	1			*	*	2	8	3			
X1-H A008		ESCUTCHEON: B4638; 03860	ea	1										
X2-H A009		SCREW, MACHINE: MS35200-46; 96906	ea	4										
P-H A010	6625-717-7018	CIRCUIT CARD ASSEMBLY: C4625; 03860	ea	1			2	3	6	71	3	9-29	A1	
P-H A012	5910-904-8488	CAPACITOR, FIXED, ELECTROLYTIC: CE11C350F; 81349	ea	1			2	6	11		3	9-29	A1C1	
P-H A013		CAPACITOR, FIXED, ELECTROLYTIC: CE11CO80H; 81349	ea	1			*	*	2		3	9-29	A1C2	
P-H A015	5961-842-9864	SEMICONDUCTOR DEVICE,  DIODE: 1N914; 81349	ea	51			5	18	33		150	9-29	A1CR1 thru A1CR51	
P-H A016		TUBE DISPLAY:  B5440; 83594	ea	5			2	3	6		50	9-29	A1DS1 thru A1D65	
P-H A017		INTEGRATED CIRCUIT:  SN74900; 01295	ea	5			2	3	5		40	9-29	A112 thru A1M6	
P-H A018		INTEGRATED CIRCUIT	ea	5			2	2	2		15	9-29	AIM7 thru ALM11	
P-H A019		DECODER: SN744IN; 01295 INTEGRATED CIRCUIT, DUAL GATE: MC830P; 04713	ea	1			*	*	2		3	9-29	A1M1	
P-H A020	5905-279-3498	RESISTOR, FIXED  COMPOSITION: RC20GF433J; 81349	ea	5			2	2	2		15	9-29	A1R1 thru A1R5	
P-H A021	590-195-6761	RESISTOR, FIXED COMPOSITION: RC20FT104J; 81349	ea	1			*	*	2		3	9-29	A1R6	
P-H A022	5905-279-2669	RESISTOR, FIXED  COMPOSITION: RC20GF133J; 81349	ea	2			*	2	2		6	9-29	A1R7, A1R8	
P-H A023	5905-171-2008	RESISTOR, FIXED COMPOSITION: RC20GF204J; 81349	ea	1			*	2	2	8	6	9-29	A1R9	
P-H A024	5905-257-0935	RESISTOR, FIXED COMPOSITION: RC20OFh32J; 81349	ea	1			*	*	2		3	9-29	A1R10	
P-H A025	5905-686-3370	RESISTOR, FIXED,  COMPOSITION: RC07GF202J; 81349	ea	2			2	3	6		50	9-29	A1R11, A1R13	
P-H A026	5905-686-3358	RESISTOR, FIXED, COMPOSITION: RCO7OF393J; 81349	ea	1			2	2	2		9	9-29	A1R12	
P-H A027	5905-726-4418	RESISTOR, FIXED COMPOSITION: RC07GF123J; 81349	ea	1			2	2	3		20	9-29	A1R20	

**SECTION IV REPAIR PARTS FOR DIRECT SUPPORT, GENERAL SUPPORT, AND DEPOT MAINTENANCE  
(CONTINUED)**

(1) SMR CODE  INDEX NO.	(2)  FEDERAL STOCK NUMBER	(3) DESCRIPTION  USABLE ON CODE  REF. NUMBER & MFR CODE	(4) UNIT OF MEAS	(5) QTY INC IN UNIT	(6) 30 DAY DS MAINT ALLOWANCE			(7) 30 DAY GS MAINT ALLOWANCE			(8) 1-YR ALW PER EQUIP CNTGY	(9) DEPOT MAINT ALW PER 100 EQUIP	(a) FIG. NO.	(10) ILLUS- TRATION	
					(a)	(b)	(c)	(a)	(b)	(c)				(b) ITEM NO./ REF DES	
					1-20	21-50	51-100	1-20	21-50	51-100					
P-H A028	5905-682-4098	RESISTOR, FIXED COIPOSITION: RC07GF392J; 81349	ea	2				2	2	2		9	9-29	A1R14, A1R15	
P-H A029	5905-801-8272	RESISTOR, FIXED COCOBITION: RC07GF511L; 81349	ea	1				2	2	2		9	9-29	A1R19	
P-H A030	5905-681-9969	RESISTOR, FIXED COMPOSITION: RC07GF332J; 81349	ea	1				2	6	11		100	9-29	A1R16	
P-H A031	5905-681-6462	RESISTOR, FIXED COMPOSITION: RC07GF102J; 81349	ea	1				2	4	8		80	9-29	A1R18	
P-H A032	5910-822-5683	CAPACITOR, FIXED, CERAMIC: CK63A10w3M; 81349	ea	1				3	9	16		150	9-29	A1C3	
P-H A033		SOCKET, DISPLAY TUBE:  SK185; 83594	ea	5				*	2	2		5	9-29	A1XDS1 thru A1XD85	
P-H A034	5961-911-6015	TRANSISTOR: 2N3251A; 81349	ea	2				*	2	2		6	9-29	A11, A1Q2	
P-H A035	5961-892-8706	TRANSISTOR: 2N3904;  04713	ea	3				7	18	33		370	9-29	A1Q3, A1Q4, A1Q5	
P-H A036	5905-683-7723	RESISTOR, FIXED, COMPOSITION: RCOT7F152J; 81349	ea	1				2	2	3		20	9-29	A1R17	
P-H A037	5905-683-2241	RESISTOR, FIXED COMPOSITION: RC07GF512J; 81349	ea	1				2	4	8		75	9-20	A1R21	
X2-H A038		CHASSIS: C4633; 03860	ea	1											
X2-H A041		COVER, BOTTOM: C4635; 03860	ea	1											
X2-H A043	5310-209-3990	WASHER, LOCK INTERNAL TOOTH: MS35333-71; 96906	ea	13											
X2-H A044	5305-054-6651	SCREW, PAN HEAD: MS51957-27; 96906	ae	13											
X2-H A045	5310-722-5998	WASHER, FLAT: MS15795-805; 96906	ea	8											
P-H A046	5935-081-2502	CONNECTOR, RECEPTACLE: 5740140-1; 02660	ea	1				*	*	2	10	4		A1J1	
X2-H A047		SCREW, PAN HEAD: MS51957-3; 96906	ea	2											
X2-H A048	5310-543-4652	WASHER, LOCK: MS35333-69; 96906	ea	2											
P-H A049		CONNECTOR, PLUG: 57-30140-1; 02660	ea	1				*	*	2	10	4		A1P1	
X2-H A050	5310-938-2013	NUT, HEXAGON: MS35649-224; 96906	ea	2											
P-H A051	5935-577-8761	CONNECTOR, COAX: 45925; 02660	ea	2				*	*	2	10	4	9-36	J7, J8	
X2-H A052	5305-059-7201	SCREW, MACHINE: 535200-27; 96906	ea	1											
X2-H A053		COVER: c4634; 03860	ea	1											
X2-H A054		PAD, TUBE: B4632; 03860	ea	2											
X2-H A056		SCREW, CAPTIVE: B5037; 03860	ea	6											
X2-H A057	5310-209-3990	WASHER LOCK: SAME AS A043	ea	6											
P-H A058	5905-577-3608	RESISTOR, VARIABLE: RV6NAYS503A; 81349	ea	1				*	*	2	8	3	9-36	R6	
P-H A059		RESISTOR, VARIABLE: B4672; 03860	e	1				*	*	2	8	3	9-36	R5	

**SECTION IV REPAIR PARTS FOR DIRECT SUPPORT, GENERAL SUPPORT, AND DEPOT MAINTENANCE  
(CONTINUED)**

(1) SMR CODE	(2) FEDERAL STOCK NUMBER	(3) DESCRIPTION  USABLE ON CODE	(4) UNIT OF MEAS	(5) QTY INC IN UNIT	(6) 30 DAY DS MAINT ALLOWANCE			(7) 30 DAY GS MAINT ALLOWANCE			(8) 1-YR ALW PER EQUIP CNTGY	(9) DEPOT MAINT ALW PER 100 EQUIP	(10) ILLUS- TRATION	
					(a)	(b)	(c)	(a)	(b)	(c)			(a)	(b)
					1-20	21-50	51-100	1-20	21-50	51-100			FIG. NO.	ITEM NO./ REF DES
P-H A060	5930-655-1581	SWITCH, TOGGLE: MS25068-23; 96906	ea	1				*	*	2	8	3	9-36	S9
P-H A061		SWITCH, ROTARY: B4663; 03860	ea	2				*	2	2	13	6	9-36	S6, S16
P-H A062		SWITCH, ROTARY: B4687; 03860	ea	1				*	*	2	8	3	9-36	S5
P-H A063		SWITCH, ROTARY: B4664; 03860	ea	1				*	2	2	13	6	9-36	S2
M-D A064		HANDLE: 211-3-02; 71279	ea	2										
X2-H A065		SCREW, FLATHEAD: MS35250-73; 96906	ea	4										
P-H A066	5905-581-2852	RESISTOR, VARIABLE: RV6NAYS252A; 81349	ea	1				*	*	2	8	3	9-36	R9
P-H A067	5905-577-0435	RESISTOR, VARIABLE: RV6NAYS502A; 81349	ea	1				*	*	2	8	3	9-36	R8
P-H A068		SWITCH, ROTARY: B4662; 03860	ea	1				*	*	2	8	3	9-36	S15
P-H A069	5935-237-2507	JACK, TELEPHONE: JJ-103; 81349	ea	2				*	*	2	10	4	9-36	J3, J5
P-H A070	5935-502-5151	CONNECTOR: UG-657/U; 80058	ea	2				*	*	2	10	4	9-36	J2, J4
P-H A071		SWITCH, ROTARY: B4660; 03860	ea	2				*	2	2	13	6	9-36	S13, S11
P-H A072		SWITCH, ROTARY: B4689; 03860	ea	1				*	*	2	8	3	9-36	S1
P-H A073	5905-905-3335	POTENTIOMETER: 3700S-1-103K; 80294	ea	1				*	*	2	8	3	9-36	R7
P-H A075	5930-655-1575	SWITCH TOGGLE: MS35059-22; 96906	ea	1				*	*	2	8	3	9-36	SI
P-H A076		HOLDER, FUSE: 340255A; 75915	ea	1				*	*	*	5	2	9-36	X1
P-H A077		FUSE: MS90078-24-1; 96906	ea	1				5	13	25	297	250	9-36	F1
P-H A078		SWITCH, ROTARY: B4666; 03860	ea	1				*	*	2	8	3	9-36	S3
P-H A079		SWITCH, ROTARY: B4661; 03860	ea	1				*	*	2	8	3	9-36	S8
P-H A080	5930-501-1749	SWITCH, PUSH: M525089-3C; 96906	ea	1				*	*	2	8	3	9-36	S12
P-H A081		RESISTOR, VARIABLE: 3700S-1-503K; 80294	ea	1				*	*	2	8	3	9-36	R4
P-H A082		METER: C4600; 03860	ea	1				*	*	2	8	3	9-36	M1
M-D A083		SHIELD, METER: C4674; 03860	ea	1										
X2-H A084	5310-043-1754	WASHER, LOCK: MS35337-79; 96906	ea	4										
X2-H A085		NUT, HEXAGON: MS35649-264; 96906	ea	4										
M-D A086		SHIELD, METER: C4673; 03860	ea	1										
X2-H A087	5305-054-5648	SCREW, PANHEAD: MS51957-14; 96906	ea	6										
X2-H A088	5310-058-2949	WASHER, LOCK: MS35337-78; 96906	ea	6										
P-H A089	6625-042-5434	METER: C4602; 03860	ea	1				*	*	2	8	3	9-36	2

**SECTION IV REPAIR PARTS FOR DIRECT SUPPORT, GENERAL SUPPORT, AND DEPOT MAINTENANCE  
(CONTINUED)**

(1) SMR CODE  INDEX NO.	(2)  FEDERAL STOCK NUMBER	(3) DESCRIPTION  USABLE ON CODE  REF. NUMBER & MFR CODE	(4) UNIT OF MEAS	(5) QTY INC IN UNIT	(6) 30 DAY DS MAINT ALLOWANCE			(7) 30 DAY GS MAINT ALLOWANCE			(8) 1-YR ALW PER EQUIP CNTGY	(9) DEPOT MAINT ALW PER 100 EQUIP	(10) ILLUS- TRATION	
					(a)	(b)	(c)	(a)	(b)	(c)			(a)	(b)
					1-20	21-50	51-100	1-20	21-50	51-100			FIG. NO.	ITEM NO./ REF DES
X2-H A090	5310-043-1754	WASHER, LOCK: SAME AS A084	ea	2										
X2-H A091		NUT, HEXAGON: SAME AS A085	ea	2										
P-H A092		INDICATOR ASSEMBLY: 222-0408-0111-273; 72619	ea	1				*	*	*	5	2		XDS1
X1-H A093		HOUSING, INDICATOR: 81-0408-01-273; 72619	ea	1										
P-O A093A	6240-223-9100	LAMP, NEON: NE-5i; 81349	ea	1				2	2	2	19	10		
P-O A094		LENS, INDICATOR LIGHT: 222-0111-202; 72619	ea	1				*	*	*	5	2		
A-H-R A095		VARIABLE FREQUENCY OSCILLATOR ASSEMBLY: C4710; 03860	ea	1									9-6	
X2-H A096	5305-579-3511	SCREW, FLATHEAD: MS35216-42; 96906	ea	4										
P-H-R A0907	6625-717-7480	CIRCUIT CARD, ASSEMBLY: C4713; 03860	ea	1				2	2	2	27	3	9-6	A2
X2-H A097A		SCREW, PANHEAD: SAME AS A087	ea	4									9-6	
X2-H A097B	5310-595-6211	WASHER, FLAT: MS15795-803; 96906	ea	4									9-6	
X2-H A0907C	5310-550-3715	WASHER, LOCK: MS35333-70; 96906	ea	4									9-6	
P-H A099		CAPACITOR, VARIABLE: DvllP8118; 73899	ea	3				*	2	2		9	9-6	A2C1, A2C7, A2C9
P-H A10M	5910-057-0929	CAPACITOR, FIXED, MICA: CMo5F100J03; 81349	ea	1				*	*	2		3	9-6	A2C2
P-H A101	5910-051-4612	CAPACITOR, FIXED, MICA: C05F220J03; 81349	ea	1				2	2	2		15	9-6	A2C3
P-H A102	5910-835-2735	CAPACITOR, MYLAR: crMio4vAK; 81349	ea	2				2	3	6		69	9-6	A2C4, A2C
P-H A103	5910-904-8488	CAPACITOR, FIXED, ELECTROLYTIC: SAME AS A0 12	ea	2				*	2	2	6		9-6	A2C6, A2C12
P-H A104		CAPACITOR, FIXED, MICA: CM05F150J03; 81349	ea	2				*	2	2	6		9-6	A2C8, A2C12
P-H A106		SEMICONDUCTOR DEVICE, DIODE: 19500/329AEL; 81349	ea	2				*	2	2	6		9-6	A2CR1, A2CR2
P-H A107		INDUCTOR: LF2W200; 73899	ea	2				*	2	2	6		9-6	A2L1, A2L2
P-H A108		INDUCTOR: MS90538-01; 6906	ea	1				*	2	2	6		9-6	A2L3
P-H A109	5961-892-8706	TRANSISTOR:	ea	2									9-6	A2Q1, A2Q2
P-H A110	5905-686-3368	SAME AS A035 RESISTOR, FIXED, COMPOSITION: RC07GF203J; 81349	ea	1				2	3	5	10	40	9-6	A2R1
P-H A111	5905-681-6462	RESISTOR, FIXED, COMPOSITION: SAME AS A031	ea	2									9-6	A2R2, A2R6
P-H A112	5905-683-7721	RESISTOR, FIXED, COMPOSITION: RC07GF1L0J; 81349	ea	2				2	3	6		50	9-6	A2R3, A2R7
P-H A113	5905-801-8272	RESISTOR, FIXED, COMPOSITION: SAME AS A029	ea	1									9-6	A2R4
P-H A114	5905-682-4098	RESISTOR, FIXED, COMPOSITION: SAME AS A028	ea	1									9-6	A2RS
P-H A115	5905-802-6941	RESISTOR, FIXED, COMPOSITION: RC07GF221J; 81349	ea	1				2	6	11		100	9-6	A2RS

**SECTION IV REPAIR PARTS FOR DIRECT SUPPORT, GENERAL SUPPORT, AND DEPOT  
MAINTENANCE(CONTINUED)**

(1) SMR CODE  INDEX NO.	(2)  FEDERAL STOCK NUMBER	(3) DESCRIPTION  USABLE ON CODE  REF. NUMBER & MFR CODE	(4) UNIT OF MEAS	(5) QTY INC IN UNIT	(6) 30 DAY DS MAINT ALLOWANCE			(7) 30 DAY GS MAINT ALLOWANCE			(8) 1-YR ALW PER EQUIP CNTGY	(9) DEPOT MAINT ALW PER 100 EQUIP	(10) ILLUS- TRATION	
					(a)	(b)	(c)	(a)	(b)	(c)			(a)	(b)
					1-20	21-50	51-100	1-20	21-50	51-100			FIG. NO.	ITEM NO./ REF DES
X2-H A119	5305-638-0653	COVER, REAR: C4653; 03860	ea	1										
X2-H A120		STAND-OP: A4813-2; 03860	ea	2										
X2-H A121	5310-550-3715	SCREW, PAN HEAD: KS35233-14; 96906	ea	2										
X2-H A122		WASHER, LOCK: SAME AS A097C	ea	2										
P-H A123	5935-081-2502	CONNECTOR, RECEPTACLE: SAME AS A046	ea	1									A2J1	
X2-H A124		SCREW PAN HEAD: SAME AS A047	ea											
X2-H A125	5310-543-4652	WASHER: SANE AS AD48	ea	2										
X2-H A126		NUT, CHEXAGO: SANE AS A050	ea	2										
P-H A126A	5935-577-8761	CONNECTOR, PLUG: SAME AS A049	ea	1									A2P1	
P-H A127		CONECTOR, COAX: SAME AS A051	ea	1									A2J2	
X2-H A128	5305-763-7822	CHASSIS: C4652; 03860	ea	1										
X2-H A129		STAND-OFF: SAME AS A120	ea	2										
X2-H A130	6625-759-8242	SCREW, FLAT HD: 9S-51959-14; 96906	ea	2										
P-H A131		SWITCH, ROTARY: SAME AS A063	ea	1										A265
P-H A132	5305-763-7822	REDUCER, SPEED: B4815; 03860	ea	2				*	2	2	5	3		
X2-H A133		SCRW FLAT HEAD: SAME AS A130	ea	6										
P-H A134	6625-759-8241	CLUTCH, FRICTION: A4821; 03860	ea	2				*	2	2	5	3		
X2-H A135		CDITER BRACRET: B4654; 03860	ea	1										
X2-H A136	5305-054-6651	TEMRIAL: B1850; 03860	ea	2										
X2-H A137		8CREW, PAN HEAD: SAME AS A044	ea	4										
X2-H A138	5310-209-3990	WASHER, LOCK INTERNAL TOOTH: SAME AS A043	ea	4										
P-H A139		CAPACITOR, VARIABLE: SA9507; 42498	ea	2				*	2	2		6		A2CIS, A2C16
X2-H A140	5310-550-3715	STOP DETAIL: A4820; 03860	ea	1										
X2-H A1411		WAS1], LOCK: SASE AS A097C	ea	2										
X2-H A142	5310-209-3990	RUT, HUXAGO: 16356h9-244; 96906	ea	2										
X2-H A143		WASRJR, LOCK INT,UAL TOOTH: SAME AS A043	ea	4										
X2-H A144	5305-05-66S51	NUT, HEXAGOO: SAEA AS A085	ea	4										
X2-H A145		SHIEIL DETAIL: A4819; 03860	ea	1										
X2-H A146		CREW, PAN BEAD: SAME A AO44	ea	10										

**SECTION IV REPAIR PARTS FOR DIRECT SUPPORT, GENERAL SUPPORT, AND DEPOT  
MAINTENANCE(CONTINUED)**

(1) SMR CODE	(2) FEDERAL STOCK NUMBER	(3) DESCRIPTION  USABLE ON CODE	(4) UNIT OF MEAS	(5) QTY INC IN UNIT	(6) 30 DAY DS MAINT ALLOWANCE			(7) 30 DAY GS MAINT ALLOWANCE			(8) 1-YR ALW PER EQUIP CNTGY	(9) DEPOT MAINT ALW PER 100 EQUIP	(10) ILLUS- TRATION	
					(a)	(b)	(c)	(a)	(b)	(c)			(a)	(b)
					1-20	21-50	51-100	1-20	21-50	51-100			FIG. NO.	ITEM NO./ REF DES
X2-H A147	5310-209-3990	WASHER, LOCK INTERNAL TOOTH: SAME AS A043	ea	10										
X2-H A148		COVER, TOP: B4658; 03860	ea	1										
X2-H A149	5305-639-47	SCREW, PAN HEAD: MS35233-27; 96906	ea	8										
X2-H A150	5310-209-3990	WASHER, LOCK INTERNAL TOOTH: SAME AS A043	ea	10										
X2-H A151		COVER, BOTTOM: B4657; 03860	ea	1										
X2-H A152	5305-639-4777	SCREW, CAPTIVE: SAME AS A056	ea	8										
X2-H A153	5310-209-3990	WASHER, LOCK INTERNAL TOOTH: SAME AS A043	ea	8										
M-D A154		SHAFT, EXTENDER: A4655; 03860	ea	2										
X2-H A155	5305-853-0799	SCREW, SET: MS51021-1; 96906	ea	4										
P-H A156	5355-680-1357	KNOB, SKIRTED: MS91528-1F2B; 96906	ea	1				*	*	*		3		
P-H A157	5355-850-0799	KNOB, ROUND: MS91528-OF1B; 96906	ea	4				*	2	2		4		
P-H A158	5355-814-0470	KNOB, CRANK: MS91528-OF1B; 96906	ea	11				2	2	2		30		
P-H A159	5355-584-4247	KNOB, CRANK MS91528-3S2B; 96906	ea	2				*	2	2		5		
P-H A160	5355-539-8942	KNOB, ROUND: MS91528-OF1B; 96906	ea	11				*	*	*		3		
P-H-R A161		POWER SUPPLY CHASSIS ASSEMBLY: D4694; 03860	ea	1										
X2-H A162	5305-045-6668	SCREW, PAN HEAD: NS51957-43; 96906	ea	4										
X2-H A163	5310-543-2739	WASHER, LOCK: MS35333-72; 96906	ea	4										
X1-H A164		CHASSIS, POWER SUPPLY: D4642; 03860	ea	1										
X2-H A165		BRACKET, FILTER: B4679; 03860	ea	1										
X2-H A166	5305-763-7822	SCREW, FLAT HEAD: SAME AS A130	ea	4										
X2-H A167	5305-054-5650	SCREW, PAN HEAD: MS51957-16; 96906	ea	2										
X2-H A168	5310-550-3715	WASHER, LOCK: SAME AS A097C	ea	2										
P-H A169		FILTER, RFI: 1JX130; 56289	ea	2				*	*	2	10	4	9-36	FL1, FL2
X2-H A170		TERMINAL, INS: 4833-1; 71279	ea	16									9-36	E1 thru E16
X2-H A171	5305-054-6650	SCREW, MACHINE: MS51957-26; 96906	ea	16										
X2-H A172	5310-209-3990	WASHER, LOCK INTERNAL TOOTH: SAME AS A043	ea	16										
P-H A173	5905-171-2003	RESISTOR, FIXED, COMPOSITION: SAME AS A023	ea	1									9-36	R15
P-H A174	5961-688-6316	SEMICONDUCTOR DEVICE,	ea	5				2	2	2	27	15	9-36	CR13 thru CR17
P-H A175	5905-686-3368	DIODE: 1N538A; 81349 RESISTOR, FIXED, COMPOSITION: SAME AS A110	ea	3									9-36	R16, R17, R18



**SECTION IV REPAIR PARTS FOR DIRECT SUPPORT, GENERAL SUPPORT, AND DEPOT  
MAINTENANCE(CONTINUED)**

(1) SMR CODE  INDEX NO.	(2)  FEDERAL STOCK NUMBER	(3) DESCRIPTION  USABLE ON CODE  REF. NUMBER & MFR CODE	(4) UNIT OF MEAS	(5) QTY INC IN UNIT	(6) 30 DAY DS MAINT ALLOWANCE			(7) 30 DAY GS MAINT ALLOWANCE			(8) 1-YR ALW PER EQUIP CNTGY	(9) DEPOT MAINT ALW PER 100 EQUIP	(a) FIG. NO.	(10) ILLUS- TRATION  (b) ITEM NO./ REF DES
					(a)	(b)	(c)	(a)	(b)	(c)				
					1-20	21-50	51-100	1-20	21-50	51-100				
P-H A176	5910-079-9474	CAPACITOR, ELECTROLYTIC: CE13C221G; 81349	ea	4				*	2	2	21	12	9-36	C8 thru C11
P-H A176A		CLIP, SPRING: 6082-15CN/010; 91506	ea	4				*	2	2		4		
P-H A176B	5305-054-6650	SCREW, MACHINE: SAME AS A171	ea	8										
X2-H A176C		NUT, HEXAGON: SAME AS A142	ea	8										
X-H A176D	5310-550-3715	WASHER, LOCK: SAME AS A097C	ea	8										
P-H A177		TRANSFORMER, POWER: C4631; 03860	ea	1				*	*	*	8	3	9-36	T1
X2-H A177A		NUT, HEXAGON: SAME AS A085	ea	1										
X2-H A177B	5310-543-2739	WASHER, LOCK: SAME AS A16 3	ea	4										
P-H A178		CAPACITOR, FIXED CERAMIC: CE41C152G ; 81349	ea	4				2	2	2	19	10	9-36	C1 thru C4
P-H A179	5910-892-2647	CAPACITOR, FIXED CERAMIC: CE41C650P; 81349	ea	1				*	*	2	8	3	9-36	CT
P-H A180		CAPACITOR, FIXED, ELECTROLYTIC: CE41C152F; 81349	ea	2				*	2	2	13	6	9-36	C5,C6
P-H A181	5940-983-6047	STRIP, b TERMINAL 37TB6; 81349	ea	1				*	*	*	5	2	9-36	TB3
X1-H A182		STRIP , ELECTRICAL: MS670-6-GEE-4A; 75382	ea	1										
X2-H A183	5305-054-6655	SCREW, MACHINE: MS51957-31; 96906	ea	2										
X2-H A184		NUT, HEXAGON: NAS671; 80205	ea	4										
X2-H A184A	5310-209-3990	WASHER, LOCK INTERNAL TOOTH: SAME AS A043	ea	4										
A-H A185		REAR PANEL ASSEMBLY: D4692; 03860	ea	1										
X2-H A186	5305-054-6669	SCREW, MACHINE: MS51957-44; 96906	ea	4										
X2-H A187	5310-543-2739	WASHER, LOCK: SAME AS A163	ea	4										
X2-H A188		REAR PANEL DETAIL: D4645; 03860	ea	1										
P-H A189	5935-578-2945	CONNECTOR, RECEPTACLE, ELECTRICAL: MS3102E-14S-6P; 96906	ea	1				*	*	*	8	3		J1
X2-H A190	5305-059-8449	SCREW, PAN HEAD: 14651957-15; 96906	ea	4										
X2-H A191	5310-550-3715	WASHER, LOCK: SAME AS A097C	ea	4										
X2-H A192		NUT, HEXAGON: SAME AS A142	ea	1										
X2-H A193	5310-595-6211	WASHER, FLAT: SAME AS A097B	ea	4										
P-H A194	5940-983-6069	TERMINAL BOARD: 40TB-8; 81349	ea	2				*	*	2	10	4		TB1, TB2
M-D A194A		MARKING STRIP: MS670Y-8-GEE, STYLE 5A; 75382	ea	2										
X2-H A195	5305-054-6651	SCREW, PAN HEAD: SAME AS A044	ea	8										

**SECTION IV REPAIR PARTS FOR DIRECT SUPPORT, GENERAL SUPPORT, AND DEPOT  
MAINTENANCE(CONTINUED)**

(1) SMR CODE  INDEX NO.	(2)  FEDERAL STOCK NUMBER	(3) DESCRIPTION  USABLE ON CODE  REF. NUMBER & MFR CODE	(4) UNIT OF MEAS	(5) QTY INC IN UNIT	(6) 30 DAY DS MAINT ALLOWANCE			(7) 30 DAY GS MAINT ALLOWANCE			(8) 1-YR ALW PER EQUIP CNTGY	(9) DEPOT MAINT ALW PER 100 EQUIP	(10) ILLUS- TRATION	
					(a)	(b)	(c)	(a)	(b)	(c)			(a)	(b)
					1-20	21-50	51-100	1-20	21-50	51-100			FIG. NO.	ITEM NO./ REF DES
X2-H A196	5310-722-5998	WASHER, FLAT: SAME AS A045	ea	8										
X2-H A197	5310-209-3990	WASHER, LOCK INTERNAL TOOTH: SAME AS A043	ea	8										
X2-H A198		NUT, HEXAGON: SAME AS AoS8s	ea	8										
X2-H A199		TERMINAL INS: SAME AS A170	ea	6										
X2-H A200	5305-054-6650	SCREW, MACHINE: SAME AS A171	ea	6										
X2-H A201	5310-209-3990	WASHER, LOCK INTERNAL TOOTH: SAME AS Ao43	ea	6										
P-H A202		RESISTOR, WIRE WOUND: RW55GR35; 81349	ea	2				*	2	2	13	6	9-36	R1, R2
P-H A203	5905-202-0377	RESISTOR, WIRE WOUND: RW55VIRO; 81349	ea	1				*	*	2	8	3	9-36	R3
A-H A204		HEAT SINK ASSEMBLY: D4685; 03860	ea	1										
X2-H A205	5305-054-6667	SCREW, PAN HEAD: MS51957-42; 96906	ea	8										
X2-H A206	5310-543-2739	WASHER, LOCK: SAME AS A163	ea	8										
X2-H A207		HEAT SINK, DETAIL: D4646; 03860	ea	1										
P-H A208	5961-809-9049	SEMICONDUCTOR DEVICE, DIODE: IN1614; 81349	ea	12				2	3	4	46	30	9-36	CR1, CR2
P-H A209	5961-226-8692	TRANSISTOR: 2N1489; 81349	ea	3				2	2	2	18	9	9-36	Q1, Q2, Q3
P-H A210	5935-990-1441	SOCKET, TRANSISTOR:  803816G; 91506	ea	3				*	2	2	13	6		XQ1, XQ2, XQ3
X2-H A211		SCREW, PAN HEAD: MS51957-8; 96906	ea	6										
X2-H A212	5310-543-4652	WASHER: SAME AS Ao48	ea	6										
X2-H A213	5319-938-2013	NUT, HEXAGON: SAME AS A050	ea	6										
X2-H A214	5305-054-6655	SCREW, MACHINE: SAME AS A183	ea	6										
P-H A216	5935-502-5151	CONNECTOR: SAME AS A070	ea	2										J11, J12
A-H A217		PRINTED CIRCUIT CARD HOLDER ASSEMBLY: D4716; 03860	ea	1										
X2-H A218	5305-059-8449	SCREW, PAN HEAD: SAME AS A190	ea	4										
X2-H A219	5310-209-3990	WASHER, LOCK INTERNAL TOOTH: SAME AS A043	ea	4										
X2-H A220		PC, CARD HOLDER DETAIL: D4641; 03860	ea	1										
P-H A221		CONNECTOR: 143-022-01-102;  02660	ea	7				2	3	4	46	30		XA10 thru XA16
X2-H A222	5305-054-5651	SCREW, PAN HEAD: MS51957-17; 96906	ea	14										
X2-H A223	5319-595-6211	WASHER, FLAT: SAME AS A097B	ea	14										
X2-H A224	5319-550-6715	WASHER, LOCK: SAME AS A097C	ea	14										

**SECTION IV REPAIR PARTS FOR DIRECT SUPPORT, GENERAL SUPPORT, AND DEPOT  
MAINTENANCE(CONTINUED)**

(1) SMR CODE  INDEX NO.	(2)  FEDERAL STOCK NUMBER	(3) DESCRIPTION  USABLE ON CODE  REF. NUMBER & MFR CODE	(4) UNIT OF MEAS	(5) QTY INC IN UNIT	(6) 30 DAY DS MAINT ALLOWANCE			(7) 30 DAY GS MAINT ALLOWANCE			(8) 1-YR ALW PER EQUIP CNTGY	(9) DEPOT MAINT ALW PER 100 EQUIP	(10) ILLUS- TRATION	
					(a)	(b)	(c)	(a)	(b)	(c)			(a)	(b)
					1-20	21-50	51-100	1-20	21-50	51-100			FIG. NO.	ITEM NO./ REF DES
X2-H A225		NUT, HEXAGON: SAME AS A142	ea	14										
X2-H A226		END PLATE DETAIL: C4648-001; 03860	ea	1										
X2-H A227		END PLATE DETAIL: C4648-002; 03860	ea	1										
X2-H A228		BRACKET: A4649; 03860	ea	1										
X2-H A229	5305-054-6651	SCREW, PAN HEAD: SAME AS A044	ea	18										
X2-H A230	5310-209-3990	WASHER, LOCK INTERNAL TOOTH: SAME AS A043	ea	18										
A-H A231		PC, CARD HOLDER ASSEMBLY: D4712; 03860	ea	1										
X2-H A232	5305-054-6652	SCREW, PAN HEAD: MS51957-28; 96906	ea	4										
X2-H A233	5310-209-3990	WASHER, LOCK INTERNAL TOOTH: SAME AS A043	ea	4										
P-H A234		CONECTOR:  SAME AS A221	ea	8										
X2-H A235	5305-054-5651	SCREW, PAN HEAD: SAME AS A222	ea	16										
X2-H A236	5310-595-6211	WASHER, FLAT: SAME AS A097B	ea	16										
X2-H A237	5310-550-3715	WASHER, LOCK: SAME AS A097C	ea	16										
X2-H A238		NUT, HEXAGON: SAME AS A142	ea	16										
X2-H A239		END PLATE, DETAIL: SAME AS A226	ea	2										
X2-H A240	5305-054-6651	SCREW, PAN HEAD: SAME AS A044	ea	16										
X2-H A241	5310-209-3990	WASHER, LOCK INTERNAL TOOTH SAME AS A043	ea	16										
A-H A242		SIDE PANEL RT: D4643; 03860	ea	1										
X2-H A243	5305-054-6668	SCREW, PAN HEAD: SAME AS A62	ea	4										
X2-H A244	5310-543-2739	WASHER, LOCK: SAME AS A163	ea	4										
12-H A245	5305-054-6670	SCREW, PAN HEAD: MS51957-45; 96906	ea	4										
X2-H A2146		SCREW, FLAT HEAD: M851959-27; 96906	ea	4										
X2-H A247	5305-054-6651	SCREW, PAN HEAD: SAME AS A042	ea	4										
X2-H A248	5310-209-3990	WASHER, LOCK INTERNAL TOOTH: SAME AS A043	ea	4										
A-H A249		SIDE PANEL, LEFT: D4644; 03890	ea	1										
X2-H A250	5305-054-6668	SCREW, PAN HEAD: SAME AS A162	ea	4										
X2-H A251	5310-543-2739	WASHER, LOCK: SAME AS A163	ea	4										
X2-H A252	5305-051-6670	SCREW, PAN HEAD: SAME AS A245	ea	4										

XA3 thru  
XA9, XA19

**SECTION II REPAIR PARTS FOR DIRECT SUPPORT, GENERAL SUPPORT, AND DEPOT MAINTENANCE  
(CONTINUED)**

(1) SMR CODE  INDEX NO.	(2)  FEDERAL STOCK NUMBER	(3) DESCRIPTION  USABLE ON CODE  REF. NUMBER & MFR CODE	(4) UNIT OF MEAS	(5) QTY INC IN UNIT	(6) 30 DAY DS MAINT ALLOWANCE			(7) 30 DAY GS MAINT ALLOWANCE			(8) 1-YR ALW PER EQUIP CNTGY	(9) DEPOT MAINT ALW PER 100 EQUIP	(10) ILLUS- TRATION	
					(a) 1-20	(b) 21-50	(c) 51-100	(a) 1-20	(b) 21-50	(c) 51-100			(a) FIG. NO.	(b) ITEM NO./ REF DES
					X2-H A253	5305-054-6651	SCREW, FLAT HEAD: SAME AS A246	ea	4					
X2-H A254	SCREW, PAN HEAD: SAME AS A044	ea	4											
X2-H A255	5310-209-3990	WASHER, LOCK MATERIAL TOOTH: SAME AS A043	ea	4										
X2-H A256		COVER, FILTER: B4678; 03860	ea	1										
X2-H A257	5305-054-5648	SCREW, PAN HEAD: SAME AS A087	ea	6										
X2-H A258		WASHER, LOCK: SAME AS A097C	ma	6										
P-O-R A259	6625-771-0641	CIRCUIT CARD, ASSEMBLY: C4699-1; 03860	ea	1				2	4	8	50	3	9-14	A7
X1-H A260		CIRCUIT CARD: C4725; 03860	ea	1										9-14
P-H A261	5940-271-4030	TERMINAL: M817122-5; 96906	ea	6				2	4	8	15	10	9-14	A7E1 thru ATE5
P-H A264	5905-681-8818	RESISTOR, FIXED, COMPOSITION: RC07GF153J; 81349	ea	3				2	3	4		27	9-14	ATR1, ATR3, A7R5
P-H A265	5905-726-3807	RESISTOR, FIXED COMPOSITION: RC07GF912J; 81349	ea	3				2	2	3		20	9-14	A7R2, A7R4, A7R6
P-H A266	5905-892-6941	RESISTOR, FIXED, COMPOSITION: SAME AS A115	ea	3									9-14	A7R7, ATR8, ATR9
P-H A267	5905-723-5251	RESISTOR, FIXED, COMPOSITION: RC07GF222J; 81349	ea	3				3	7	13		125	9-14	A7R10, A7R11,A7R12
P-H A268	5905-834-2750	RESISTOR, FIXED, FILM: RN65C4751F; 81349 (ITEM NO. A7R13, ATR14, A7R15, ATR28, ATR29, ATR30, ATR43, ATR44, ATR45, ATR58, A7R59, A7R60)	ea	12				2	4	8		75	9-14	(See Des. Column)
P-H A269	5905-752-3974	RESISTOR, FIXED FILM: RN65C2212F; 81349 (ITEM NO. ATR16, ATR17, A7R18, A7R31, ATR32, A7R33, ATR46, A7R47, A7R48)	ea	9				2	3	6		50	9-14	(See Des. Column)
P-H A270	5905-681-9969	RESISTOR, FIXED, COMPOSITION: SAME AS A030 (ITEM NO. ATR19, A7R20, A7R21, ATR34, ATR35, A7R36, A7R49, ATR50, ATR51, A7R67, A7R68, A7R69)	ea	12									9-14	(See Des. Column)
P-H A271	5905-688-3738	RESISTOR, FIXED COMPOSITION: RC07GF182J; 81349 (ITEM NO. A7R22, ATR23, A7R24, A7R37, ATR38, A7R39, ATR52, ATR53, A7R54, A7R70, ATR71, ATR72)	ea	12				2	6	11		60	9-14	(See Des. Column)
P-H A272	5905-682-4097	RESISTOR, FIXED, COMPOSITION: RC07GF302J; 81349 (ITEM NO. A7R25, A7R26, A7R27, A7R40, A7R41 A7R2A, A7R42, ATR5S, ATR56, A7R57, ATR73, ATR74, ATR75)	ea	12				2	6	11		60	9-14	(See Des. Column)
P-H A273	5905-782-0909	RESISTOR, FIXED, FILM: RN65C4422F; 81349	ea	3				2	2	2		18	9-14	A7R62, A7R64, ATR65
P-H A277	5910-901-5875	CAPACITOR, ELECTROLYTIC: CEIIC500F; 81349	ea	3				2	2	3		18	9-14	A7C1, A7C2, A7C3
P-H A278		CAPACITOR, FIXED, MYLAR: X663FR1555.5; 84411	ea	4				2	3	4		30	9-14	A7C4, A7C10, A7C16 A7C22
P-H A279		CAPACITOR, FIXED, MYLAR: X663FR2245.5; 84411	ea	4				2	2	3		25	9-14	A7C7, A7C13, A7C19 A7C25
P-H A280		CAPACITOR, FIXED, MYLAR: X663FR3945.5; 84411	ea	4				2	2	3		25	9-14	A7C5, A7C11, A7C17 A7C23
P-H A281		CAPACITOR, FIXED, MYLAR: X663FR6835.5; 84411	ea	4				2	2	3		25	9-14	A7CS, A7C14, A7C20 A7C26

**SECTION II REPAIR PARTS FOR DIRECT SUPPORT, GENERAL SUPPORT, AND DEPOT MAINTENANCE**

**(CONTINUED)**

(1) SMR CODE  INDEX NO.	(2)  FEDERAL STOCK NUMBER	(3) DESCRIPTION  USABLE ON CODE  REF. NUMBER & MFR CODE	(4) UNIT OF MEAS	(5) QTY INC IN UNIT	(6) 30 DAY DS MAINT ALLOWANCE			(7) 30 DAY GS MAINT ALLOWANCE			(8) 1-YR ALW PER EQUIP CNTGY	(9) DEPOT MAINT ALW PER 100 EQUIP	(10) ILLUS- TRATION	
					(a)	(b)	(c)	(a)	(b)	(c)			(a)	(b)
					1-20	21-50	51-100	1-20	21-50	51-100			FIG. NO.	ITEM NO./ REF DES
P-H A282		CAPACITOR, FIXED, MYLAR: X663FR1545.5; 84411	ea	4				2	2	3		25	9-14	A7C6,A7C12, A7C18,A7C24
P-H A283		CAPACITOR, FIXED, MYLAR: X663FR2235.5; 84411	ea	4				2	2	3		25	9-14	A7C9,A7C15, A7C2,A7C27
P-H A284	5910-822-5683	CAPACITOR, FIXED, CERAMIC: SAME AS A032	ea	6									9-14	A7C30 thru A7C35
P-H A285	5910-904-8488	CAPACITOR, FIXED, ELECTROLYTIC: SAME AS A012	ea	2									9-14	A7C28,A7C29
P-H A286	5961-892-8706	TRANSISTOR: SAME AS A035 (ITEM NO. A7Q1 thru A7Q6, A7Q10, A7Q11, A7Q12, A7Q16, A7Q17, A7Q18, A7Q22, A7Q23, A7Q24)	ea	15									9-14	(See Des. Column)
P-H A287	5961-072-0128	TRANSISTOR: 2N3906; 04713 (ITEM NO. A7Q7, A7Q8, A7Q9, A7Q13, A7Q14, A7Q15, A7Q19, A7Q20, A7Q21, A7Q25, A7Q26, A7Q27)	ea	12				3	9	16		150	9-14	(See Des. Column)
P-H-P A288	6625-717-7024	CIRCUIT CARD, ASSEMBLY: B4806: 03860	ea	1				2	4	8	35	3	9-42	A20
X2-H A289		STAND-OFF: A4813-1; 03860	ea	4										
X2-H A290	5305-054-5647	SCREW, PAN HEAD: MS51957-13; 96906	ea	8										
X2-H A291	5310-595-6211	WASHER, FLAT: SAE AS A097B	ea	4										
X2-H A292	5310-550-3715	WASHER, LOCK: SAME AS A90TC	ea	8										
X1-H A293		CIRCUIT CARD: B4807: 03860	ea	1										
P-H A294	5940-271-4030	TERMINAL: SAME AS A261	ea	6										A20E1 thru A20E6
P-H A295	5910-904-8488	CAPACITOR, FIXED, ELECTROLYTIC: SAME AS A012	ea	1									9-42	A20C1
P-H A296	5905-686-9997	RESISTOR, FIXED, COMPOSITION: RC07GF6821; 81349	ea	1				2	2	3	18		9-42	A20R1
P-H A297	5905-681-9969	RESISTOR, FIXED, COMPOSITION: SAME AS A030	ea	1									9-42	A20R2
P-H A298	5905-683-2238	RESISTOR, FIXED, COMPOSITION: RC07OTGF103J; 81349	ea	1				2	3	6	50		9-42	A20R3
P-H A299	5905-689-6799	RESISTOR, VARIABLE, TRIM POT: RT12C2P502; 80294	ea	1				2	2	3	20		9-42	A20R4
P-H A299A	5905-805-9714	RESISTOR, FIXED, COMPOSITION: RC07GF362J; 81349	ea	1				2	2	3	20		9-42	A20R5
P-O-B A300	6625-764-8509	CIRCUIT CARD, ASSEMBLY: C4699-2; 03860	ea	1				2	4	8	45	3	9-15	A13
P-H A302	5940-271-4030	TERMINAL: SAME AS A261	ea	6									9-15	A13E1 thru A13E6
P-H A305	5905-681-8818	RESISTOR, FIXED, COMPOSITION: SAME A A264	ea	3									9-15	A13R1, A13R3, A13R5
P-H A306	5905-726-3807	RESISTOR, FIXED, COMPOSITION: SAME AS A265	ea	3									9-15	A13R2, A13R4, A13R6
P-H A307	5905-892-6941	RESISTOR, FIXED, COPITION: SAME AS A115	ea	3									9-15	A13R7, A13R8, A13R9
P-H A308	5905-723-5251	RESISTOR, FIXED, COMPOSITION: SAME AS A267	ea	3									9-15	A13R10, A13R11 A13R12
P-H A309	5905-834-2750	RESISTOR, FIXED, COMPOSITION: SAME AS A268 (Item No. A13R13, A13R14, A13R15, A13R28, A13R29, A13R30, A13R43, A13R44, A13R45, A13R58, A13R59, A13R60)	ea	12									9-15	(See Des. Column)

**SECTION IV REPAIR PARTS FOR DIRECT SUPPORT, GENERAL SUPPORT, AND DEPOT MAINTENANCE  
(CONTINUED)**

(1) SMR CODE	(2) FEDERAL STOCK NUMBER	(3) DESCRIPTION  USABLE ON CODE	(4) UNIT OF MEAS	(5) QTY INC IN UNIT	(6) 30 DAY DS MAINT ALLOWANCE			(7) 30 DAY GS MAINT ALLOWANCE			(8) 1-YR ALW PER EQUIP CNTGY	(9) DEPOT MAINT ALW PER 100 EQUIP	(10) ILLUS- TRATION	
					(a)	(b)	(c)	(a)	(b)	(c)			(a)	(b)
					1-20	21-50	51-100	1-20	21-50	51-100			FIG. NO.	ITEM NO./ REF DES
P-H A310	5905-752-3974	RESISTOR, FIXED, FILM: SAME AS A269 (ITEM NO. A13R16, A13R17, A13R18, A13R31, A13R32, A13R33, A13R46, A13R47, A13R548)	ea	9									9-15	(See Des. Column)
P-H A311	5905-681-9969	RESISTOR, FIXED, COMPOSITION: SAME AS A030 (ITEM NO. A13R19, A13R20, A13R21, A13R34, A13R35, A13R36, A13R49, A13R50, A13R51, A13R67, A13R68, A13R69)	ea	12									9-15	(See Des. Column)
P-H A312	5905-688-3738	RESISTOR, FIXED, COMPOSITION: SAME AS A271 (ITEM NO. A13R22, A13R23, A13R24, A13R37, A13R38, A13R39, A13R52, A13R53, A13R54, A13R70, A13R71, A13R72)	ea	12									9-15	(See Des. Column)
P-H A313	5905-682-4097	RESISTOR, FIXED, COMPOSITION: SAME AS A272 (ITEM NO. A13R25, A13R26, A13R27, A13R40, A13R41, A13R42, A13R55, A13R56, A13R57, A13R73, A13R74, A13R75)	ea	12									9-15	(See Des. Column)
P-H A314	5905-782-0909	RESISTOR, FIXED, FILM: SAME AS A273	ea	3									9-15	A13R62, A13R64 A13R66 A13R61
P-H A315		RESISTOR, FIXED, FILM: SELECTED VALUES FROM-N65C7501F thru RN65C5102F 81349	ea	1				*	*	2		3	9-15	A13R63
P-H A316		RESISTOR, FIXED, FILM: SELECTED VALUES FROM- RN65C7501F thru RN65C5102F;	ea	1				*	*	2		3	9-15	A13R65
P-H 81349 P-H A317		RESISTOR, FIXED, FILM: SELECTED VALUES FROM- RN65C7501F thru RN65C5102F; 81349	ea	1				*	*	2		3	9-15	A13C1, A13C2, A13C3
P-H A318	5910-901-5875	CAPACITOR, ELECTROLYTIC:	ea	3									9-15	A13C4, A13C10 A13.16, A13C22 A13C7, A13C13 A13C19, A13C25 A13C5, A13C11 A13C17, A13C23 A13C8, A13C14 A13C20, A13C26 A13C6, A13C12 A13C18, A13C24 A13C9, A13C15 A13C21, A13C27
P-H A319		SAME AS A277 CAPACITOR, FIXED, MYLAR:	ea	4									9-15	A13C30 thru A13C35 A13C28,
P-H A320		SAME AS A278 CAPACITOR, FIXED, MYLAR:	ea	4									9-15	(See Des. Column)
P-H A321		SAME AS A279 CAPACITOR, FIXED, MYLAR:	ea	4									9-15	(See Des. Column)
P-H A322		SAME AS A280 CAPACITOR, FIXED, MYLAR:	ea	4									9-15	A9
P-H A323		SAME AS A281 CAPACITOR, FIXED, MYLAR:	ea	4									9-15	A9CI
P-H A324		SAME AS A282 CAPACITOR, FIXED, MYLAR:	ea	4									9-15	
P-H A325	5910-822-5683	SAME AS A283 CAPACITOR, FIXED, MYLAR:	ea	4									9-15	
P-H A13C29 A326 P-H A326A	5910-904-8488	CAPACITOR, FIXED, ELECTROLYTIC: SAME AS A012 TRANSISTOR: SAME AS A035 (ITEM NO. A13Q1 thru A13Q6, A13Q10Q, A13Q11, A13Q12, A13Q16, A13Q17, A13Q18, A13Q22, A13Q23, A13Q24)	ea	15									9-15	
P-H A326B	5961-892-8706	TRANSISTOR: SAME AS A287 (ITEM NO. A13Q7, A13Q8, A13Q9, A13Q13, A13Q14, A13Q15, A13Q19, A13Q20, A13Q21, A13Q25, A13Q26, A13Q27)	ea	12									9-15	
P-O-R A327	6625-771-0224	CIRCUIT CARD, ASSEMBLY: C4701; 03860	ea	1				2	2	3	40	3	9-27	
P-H A329	5910-904-8488	CAPACITOR, FIXED, ELECTROLYTIC: SAME AS A012	ea	1									9-27	

**SECTION II REPAIR PARTS FOR DIRECT SUPPORT, GENERAL SUPPORT, AND DEPOT MAINTENANCE**

**(CONTINUED)**

(1) SMR CODE	(2) FEDERAL STOCK NUMBER	(3) DESCRIPTION  USABLE ON CODE	(4) UNIT OF MEAS	(5) QTY INC IN UNIT	(6) 30 DAY DS MAINT ALLOWANCE			(7) 30 DAY GS MAINT ALLOWANCE			(8) 1-YR ALW PER EQUIP CNTGY	(9) DEPOT MAINT ALW PER 100 EQUIP	(10) ILLUS- TRATION	
					(a) 1-20	(b) 21-50	(c) 51-100	(a) 1-20	(b) 21-50	(c) 51-100			(a) FIG. NO.	(b) ITEM NO./ REF DES
P-H A330	5910-822-5683	CAPACITOR, FIXED, CERAMIC: SAME AS A032	ea	1								9-27	A9C2	
P-H A331	5961-842-9864	SEMICONDUCTOR DEVICE, DIODE: SAME AS A015	ea	26								9-27	A9CR1 thru A9CR26	
P-H A332	5962-066-0174	INTEGRATED CIRCUIT: MC845P; 04713	ea	8				2	3	6	86	63	9-27	A9M1 thru A9NB
P-H A333	5905-686-3368	RESISTOR, FIXED, COMPOSITION: SAME AS A110	ea	13									9-27	A9R1 thru A9R13
P-H A334	5905-681-6462	RESISTOR, FIXED, COMPOSITION: SAME AS A031	ea	1									9-27	A9R14
P-O-R A335	6625-771-0230	CIRCUIT CARD, ASSEMBLY: C4702; 03860	ea	1				2	2	2	30	3	9-25	A10
P-H A337	5910-904-8488	CAPACITOR, FIXED, ELECTROLYTIC: SAME AS A012	ea	1									9-25	A10Ci
P-H A338	5910-822-5683	CAPACITOR, FIXED, CERAMIC: SAME AS A032	ea	1									9-25	A10C2
P-H A339		INTEGRATED CIRCUIT: MC846P; 04713	ea	1				*	*	2	8	3	9-25	A10L2 A10L6
P-H A340		INTEGRATED CIRCUIT: SAME AS A017	ea	7									9-25	A10M2, A10M3, A10L6 A10N10 thru A10O13
P-H A341	5962-066-0174	INTEGRATED CIRCUIT: SAME AS A332	ea	12									9-25	A10M4, A10O5, A10O8 A10I9, A01M14 thru A10M21 A11O7
P-H A342		INTEGRATED CIRCUIT: MC844P; 04713	ea	1				*	*	2	8	3	9-25	A10R1, A10R2, A10R3
P-H A343	5905-683-2238	RESISTOR, FIXED, COMPOSITION: SAME AS A298	ea	3									9-25	A10R4, A10R5 A5
P-H A344	5905-686-3370	RESISTOR, FIXED, COMPOSITION: SAME AS A025	ea	2									9-25	A10R4, A10R5 A5
P-O-R A345	6625-771-0615	CIRCUIT CARD ASSEMBLY: C4697; 03860	ea	1				2	2	3	33	3	9-33	A5
X2-H A349		CLAMP: 6087-1CR/.010; 91506	ea	1										
X2-H A351		HEAT SINK: 2207/PR10A; 13103	ea	1										
X2-H A352	5305-054-5646	SCREW PAN HEAD: MS51957-12; 96906	ea	2										
X2-H A353	5310-550-3715	WASHER, LOCK: SAME AS A097C	ea	2										
X2-H A3514	5310-595-6211	WASHER, FLAT: SAME AS A097B	ea	2										
P-H A355	5961-813-9360	TRANSISTOR: 2N1613; 81349	ea	3					2	2	3	25	9-33	A5Q4, A5Q7
P-H A356	5961-855-1551	TRANSISTOR: 2N1132; 81349	ea	1					2	2	2	9	9-33	A5Q3
P-H A357	5961-072-0128	TRANSISTOR: SAME AS A287	ea	2									9-33	A5Q5, A5Q2
P-H A358	5961-892-8706	TRANSISTOR: SAME AS A035	a	2									9-33	A5Q8, A5Q9
P-H A359	5961-6886316	SEMICONDUCTOR DEVICE, DIODE: SAME AS A174	ea	2									9-33	ASCR1, A5CR2 A5CR4
P-H A360	5961-849-4176	SEMICONDUCTOR DEVICE, DIODE	ea	2				*	2	2		6	9-33	ASCR3, A5CR4
P-H A361		ZENER: 213019B; 81349	ea	1				*	*	2		3	9-33	A5R1
P-H A362	5905-892-6941	RESISTOR, FIXED, W/W: RW55V331L; 81349	ea	2									9-33	A5R2, A5R10
P-H A362	SAME AS A115	RESISTOR, FIXED, COMPOSITION: SAME AS A115	ea	2									9-33	A5R2, A5R10

**SECTION II REPAIR PARTS FOR DIRECT SUPPORT, GENERAL SUPPORT, AND DEPOT MAINTENANCE  
(CONTINUED)**

(1) SMR CODE  INDEX NO.	(2) FEDERAL STOCK NUMBER	(3) DESCRIPTION  USABLE ON CODE  REF. NUMBER & MFR CODE	(4) UNIT OF MEAS	(5) QTY INC IN UNIT	(6) 30 DAY DS MAINT ALLOWANCE			(7) 30 DAY GS MAINT ALLOWANCE			(8) 1-YR ALW PER EQUIP CNTGY	(9) DEPOT MAINT ALW PER 100 EQUIP	(10) ILLUS- TRATION	
					(a)	(b)	(c)	(a)	(b)	(c)			(a)	(b)
					1-20	21-50	51-100	1-20	21-50	51-100			FIG. NO.	ITEM NO./ REF DES
P-H	5905-723-5251	RESISTOR, FIXED, COMPOSITION: SAME AS A267	ea	2								9-33	A5R4, A5R6	
A363 P-H	5905-688-3738	RESISTOR, FIXED, COMPOSITION: SAME A8 A271	ea	1								9-33	ASR5	
A364 P-H	5905-691-0195	RESISTOR, FIXED, COMPOSITION: RCOT7GF562J; 81349	ea	1				2	2	2		10	9-33	A5RT
A365 P-H	5905-801-6998	RESISTOR, FIXED, COMPOSITION: RC7TGF621J; 81349	ea	1				2	2	2		10	9-33	A5R8
A366 P-H	5905-833-2271	RESISTOR, FIXED, FILM: RN65C110F; 81349	ea	1				2	2	2		10	9-33	A5R11
A367 P-H	5905-683-2241	RESISTOR, FIXED, COMPOSITION: SAME AS A037	ea	1									9-33	A5R9
A368 P-H		RESISTOR, FIXED, FILM: RU65C3651F; 81349	ea	1				*	2	2		6	9-33	A5R12
A369 P-H	5905-828-7762	RESISTOR, FIXED, FILM: RN65C3920F; 81349	ea	1				*	2	2		6	9-33	A5R13
A370 P-H	5905-686-9996	RESISTOR, FIXED, COMPOSITION: RC07GF821J; 81349	ea	1				*	2	2		6	9-33	A5R14
A371 P-H		RESISTOR, FIXED, FILM: RN65C3741F; 81349	ea	1				*	*	2		3	9-33	A5R15
A372 P-H	5905-807-2570	RESISTOR, FIXED, FILM: RN65C9760F; 81349	ea	1				*	*	2		3	9-33	A5R16
A373 P-H	5905-805-9714	RESISTOR, FIXED, COMPOSITION: SAME AS A299A	ea	1									9-33	A5R17
A374 P-H	5905-683-2236	RESISTOR, FIXED, COMPOSITION: RC007F391J; 81349	ea	1				*	*	2		3	9-33	A5R18
A375 P-H	5905-681-6462	RESISTOR, FIXED, COMPOSITION: SAME AS A031	ea	1									9-33	A5R19
A376 P-H	5905-752-3602	RESISTOR, FIXED, FILM: RN65C1001F; 81349	ea	2				2	2	2		15	9-33	A5R20, A5R22
A377 P-H	5905-717-5884	RESISTOR, VARIABLE: RT12C2P102; 81349	ea	1				*	2	2		6	9-33	A5R21
A378 P-H		CAPACITOR, FIXED, ELECTROLYTIC: CE13C9000;	ea	2				*	2	2		6	9-33	A5SC, A5C3
A379 81349 P-H	5910-943-4079	CAPACITOR, FIXED, ELECTROLYTIC: CE13C131F;	ea	1				*	*	2		3	9-33	ASC4
A380 81349 P-H	5910-835-2739	CAPACITOR, FIXED, PLASTIC: CT-154VAK; 81349	ea	1				*	*	2		3	9-33	A5C5
A381 P-H	5910-835-2711	CAPACITOR, MYLAR: CTM-103VAK; 81349	ea	1				2	2	2		9	9-33	A5C6
A382 P-H	5910-943-9298	CAPACITOR, FIXED, ELECTROLYTIC: CE11C5000D;	ea	1				*	*	2		3	9-33	A5C7
A383 81349 P-H	5910-835-2735	CAPACITOR, MYLAR: SAME AS A102	ea	1									9-33	A5C8
A384 P-O-R	6625-771-0654	CIRCUIT CARD ASSEMBLY: C4703; 03860	ea	1				2	3	5	59	3	9-31	A11
A385 X2-H		HEAT SINK: SAME AS A351	ea	2										
A387 X2-H	5305-054-5646	SCREW PAN HEAD: SAME AS A352	ea	4										
A388 X2-H	5310-550-3715	WASHER, LOCK: SAE AS A97C	ea	4										
A389 X2-H	5310-595-6211	WASHER, FLAT: SAM AS A097B	ea	4										
A390														



**SECTION II REPAIR PARTS FOR DIRECT SUPPORT, GENERAL SUPPORT, AND DEPOT MAINTENANCE  
(CONTINUED)**

(1) SMR CODE	(2) FEDERAL STOCK NUMBER	(3) DESCRIPTION  USABLE ON CODE	(4) UNIT OF MEAS	(5) QTY INC IN UNIT	(6) 30 DAY DS MAINT ALLOWANCE			(7) 30 DAY GS MAINT ALLOWANCE			(8) 1-YR ALW PER EQUIP CNTGY	(9) DEPOT MAINT ALW PER 100 EQUIP	(10) ILLUS- TRATION	
					(a) 1-20	(b) 21-50	(c) 51-100	(a) 1-20	(b) 21-50	(c) 51-100			(a) FIG. NO.	(b) ITEM NO./ REF DES
P-H A390A	5940-271-4030	TERMINAL: SAME AS A261	ea	4										
P-H A390B	5961-752-6121	SEMICONDUCTOR DEVICE, DIODE, ZENER: 111753A; 81349	ea			2	2	2	3	20		9-31	A111CR, A11CR2	
P-H A391	5961-855-1551	TRANSISTOR: SAME AS A356	ea	2								9-31	A11Q5, A11Q7	
P-H A392	5961-072-0128	TRANSISTOR: SAME AS A287	ea	4								9-31	A11Q1 thru A11Q4	
P-H A393	5961-813-9360	TRANSISTOR:  SAME AS A355	ea	6								9-31	A11Q6, A11Q8 A11Q100, A11Q11 A11Q13, A11Q4	
P-H A394	5961-892-8706	TRANSISTOR: SAME AS A035	ea	4								9-31	A11Q15S thru A11Q18	
P-H A395	5910-835-2715	CAPACITOR, FIXED, PLASTIC: CTM-153VAK; 81349	ea	2				*	2	2	6	9-31	A11Ci A11C2	
P-H A396	5910-835-2735	CAPACITOR, MYLAR:  SAME AS A102	ea	4								9-31	A11C3, A11C4 A11C9, ALC100 A11C5	
P-H A397	5910-904-8488	CAPACITOR, FIXED, ELECTROLYTIC: SAME AS A012	ea	4								9-31	thru A11C8	
P-H A398	5905-802-6941	RESISTOR, FIXED, FILM:  SAME AS A115S	ea	4								9-31	A11R1, A11R2 A11R17, A11R19	
P-H A399	5905-581-1963	RESISTOR, FIXED, W/W: RW59G251K; 81349	ea	2				*	2	2	6	9-31	A11R3, A11R5	
P-H A400	5905-805-9714	RESISTOR, FIXED, COMPOSITION: SAME AS A299A	ea	4								9-31	A11R7, A11R8 A11R11, A11R2	
P-H A401	5905-800-8063	RESISTOR, FIXED, COMPOSITION: RC07GF112J; A1349	ea	2				2	2	2	9	9-31	A11R9, A11R101	
P-H A402	5905-686-9997	RESISTOR, FIXED, COMPOSITION : SAME AS A296	ea	2								9-31	A11R13, A11R15	
P-H A403	5905-801-6998	RESISTOR, FIXED, COMPOSITION: SAME AS A366	ea	2								9-31	A11R14, A11R16	
P-H A404	5905-683-2241	RESISTOR, FIXED, COMPOSITION: SAME AS A037	ea	2								9-31	A11R1S, A11R20	
P-H A405	5905-833-2271	RESISTOR, - FIXED, FILM: SAME AS A367	ea	2								9-31	A11R21, A11R22	
P-H A406	5905-686-3370	RESISTOR, FIXED, COMPOSITION: SAME AS A025	ea	2								9-31	A11R23, A11R24	
P-H A407	5905-725-6995	RESISTOR, FIXED, COMPOSITION: RC07GF271J; 81349	ea	2				*	2	2	6	9-31	A11R25, A11R26	
P-H A408	5905-727-8001	RESISTOR, FIXED, COMPOSITION:  RC07CF681J; 81349	ea	4				2	3	4	30	9-31	A11R27, A11R28 A11R31, A11R32	
P-H A409	5905-801-6444	RESISTOR, FIXED, COMPOSITION: RC07GF911L; 81349	ea	2				2	2	2	15	9-31	A11R29 A11R30	
P-H A410	5905-806-4600	RESISTOR, FIXED, FILM:  RN65C3011F; 81349	ea	4				2	2	2	18	9-31	A11R33, A11R35 A11R36, A11R38	
P-H A411	5905-761-5409	RESISTOR, VARIABLE: RT12C2P202; 81349	ea	2				*	2	2	6	9-31	A11R34, A11R37	
P-H A411A	5961-866-5454	SEMICONDUCTOR, DEVICE, DIODE: 1821A; 81349	ea	2				2	2	2	9	9-31	A111CR3 A111CR	
P-O-R A412	6625-771-0651	CIRCUIT CARD ASSEMBLY: c4696; o3860	ea	1				2	4	8	50	3	9-4	A4
P-H A416	5910-822-5683	CAPACITOR, FIXED, CERAMIC: SAME AS A032 (ITEM RO. A4C1, AA C3, A4c6, A4C8, A4C9, A4C1 thru A4C14, A4C17, A4C18, A4C19, A4C24, A4C25, AEC26, A4 C30, A4C33, A4C35, A1C37, A1C39, A4c44)	ea	22								9-4	(See Des. Column)	

**SECTION II REPAIR PARTS FOR DIRECT SUPPORT, GENERAL SUPPORT, AND DEPOT MAINTENANCE  
(CONTINUED)**

(1) SMR CODE  INDEX NO.	(2)  FEDERAL STOCK NUMBER	(3) DESCRIPTION  USABLE ON CODE  REF. NUMBER & MFR CODE	(4) UNIT OF MEAS	(5) QTY INC IN UNIT	(6) 30 DAY DS MAINT ALLOWANCE			(7) 30 DAY GS MAINT ALLOWANCE			(8) 1-YR ALW PER EQUIP CNTGY	(9) DEPOT MAINT ALW PER 100 EQUIP	(10) ILLUS- TRATION	
					(a)	(b)	(c)	(a)	(b)	(c)			(a)	(b)
					1-20	21-50	51-100	1-20	21-50	51-100			FIG. NO.	ITEM NO./ REF DES
P-H A417	5910-060-1190	CAPACITOR, FIXED, MICA: CM06F681J03; A1349	ea	2				*	2	2		6	9-4	A4C2, A4C5
P-H A418		CAPACITOR, FIXED, CERAMIC: MC61BW104M; 00656	ea	1				*	*	2		3	9-4	A4C7
P-H A419	5910-904-8488	CAPACITOR, FIXED,  ELECTROLYTIC: SAME AS A012	ea	4									9-4	A4C4, A4C2, A4C27, A4C28
P-H A420		CAPACITOR, FIXED, MICA: CMOS5F47J03; 81349	ea	2				2	2	2		15	9-4	A4C10, A4C41
P-H A421	5910-954-1770	CAPACITOR, FIXED, MICA:  CM05F221J03; 81349	ea	5				2	2	2		15	9-4	A4C16, A4C:21,A4C23 A4C36, A4C38
P-H A422		CAPACITOR, FIXED, MICA: CM05F151G03; 81349	ea	2				2	2	2			9-4	A4C34, A4C40
P-H A425	5910-051-4612	CAPACITOR, FIXED, MICA: SAME AS A101	ea	1				*	*	2		3	9-4	A4CR1
P-H A426		SEMICONDUCTOR, DEVICE, DIODE: 14809A; 81349	ea	1				*	*	2			9-4	A4CR2, A4CR3, A4CR4
P-H A427	5961-842-9864	SEMICONDUCTOR, DEVICE,  DIODE: SAME AS A015	ea	3									9-4	A4CR5
P-H A428	5961-866-5454	SEMICONDUCTOR, DEVICE, DIODE: SAME AS A411A	ea	1									9-4	A4L1
P-H A429	5950-994-6600	INDUCTOR: MS90538-20; 96906	ea	1				*	*	2		3	9-4	A4L2, A4L3
P-H A430		INDUCTOR, VARIABLE: 3370-17; 71279	ea	2				2	2	2		10	9-4	A4, A4q2, A4q4 thru A4Q15
P-H A431	5961-892-8706	TRANSISTOR:  SAME AS A035	ea	14									9-4	A4Q3
P-H A432	5961-072-0128	TRANSISTOR: SAME AS A287	ea	1									9-4	A41L4
P-H A433		INDUCTOR: SAME AS A108	ea	1									9-4	A4R1, A4R2
P-H A434	5905-686-9995	RESISTOR, FIXED, COMPOSITION: RC07GF154J; 81349	ea	2				*	2	2		6	9-4	A4R3, A4R35
P-H A435	5905-723-5251	RESISTOR, FIXED, COMPOSITION: SAME AS A267	ea	2									9-4	A4R4
P-H A436	5905-686-3379	RESISTOR, FIXED, FILM: RN60C1002F; 81349	ea	1				*	*	2		3	9-4	A4R5
P-H A437	5905-810-0946	RESISTOR, FIXED, FILM: RN60C3921F; 81349	ea	1				*	*	2		3	9-4	A4R6
P-H A438	5905-894-0825	RESISTOR, FIXED, FILM: RN60C3920F; 81349	ea	1				*	*	2		3	9-4	A4R7
P-H A439	5905-752-3597	RESISTOR, FIXED, FILM: RN60C100LF; 81349	ea	1				*	*	2		3	9-4	A4R8
P-H A440	5905-752-3308	RESISTOR, FIXED, FILM: RI60C1211F; 81349	ea	1				*	*	2		3	9-4	A4R9
P-H A441	5905-721-1488	RESISTOR, FIXED, COMPOSITION: RC07GF150J; 81349	ea	1				*	*	2		3	9-4	A4R10, A4R48
P-H A442	5905-681-6462	RESISTOR, FIXED, COMPOSITION: SAME AS A031	ea	2									9-4	A4R11, A4R44, A4R46
P-H A443	5905-683-7721	RESISTOR, FIXED, COMPOSITION: SAME AS A112	ea	3									9-4	A4R12, A4R13, A4R17
P-H A444	5905-686-9998	RESISTOR, FIXED, COMPOSITION: RC07GF472J; 81349	ea	3				2	2	2		9	9-4	A4R14, A4R45
P-H A445	5905-802-6730	RESISTOR, FIXED, COMPOSITION: RC07GF470J; 81349	ea	2				2	2	2		15	9-4	A4R15, A4R47
P-H A446	5905-681-9969	RESISTOR, FIXED, COMPOSITION: SAME AS A030	ea	2									9-4	

**SECTION II REPAIR PARTS FOR DIRECT SUPPORT, GENERAL SUPPORT, AND DEPOT MAINTENANCE  
(CONTINUED)**

(1) SMR CODE  INDEX NO.	(2)  FEDERAL STOCK NUMBER	(3) DESCRIPTION  USABLE ON CODE  REF. NUMBER & MFR CODE	(4) UNIT OF MEAS	(5) QTY INC IN UNIT	(6) 30 DAY DS MAINT ALLOWANCE			(7) 30 DAY GS MAINT ALLOWANCE			(8) 1-YR ALW PER EQUIP CNTGY	(9) DEPOT MAINT ALW PER 100 EQUIP	(10) ILLUS- TRATION	
					(a)	(b)	(c)	(a)	(b)	(c)			(a)	(b)
					1-20	21-50	51-100	1-20	21-50	51-100			FIG. NO.	ITEM NO./ REF DES
P-H A447	5905-686-9997	RESISTOR, FIXED, COMPOSITION: SAME AS A296	ea	1								9-4	A4R16	
P-H A448	5905-686-3130	RESISTOR, FIXED, COMPOSITION: RC070F134J; 81349	ea	1				*	*	2	3	9-4	A4R18	
P-H A449	5905-726-3807	RESISTOR, FIXED, COMPOSITION: SAME AS A265	ea	1								9-4	A4R19	
P-H A450	5905-803-2908	RESISTOR, FIXED, COMPOSITION: RCOTGF303J; 81349	ea	1				2	2	2	9	9-4	A4R20	
P-S A451	5905-686-3838	RESISTOR, FIXED, COMPOSITION: RCT07F273J; 81349	ea	2				*	2	2	6	9-4	A4R21, A4R25	
P-H A452	5905-892-6941	RESISTOR, FIXED, COMPOSITION: SAME AS A115	ea	2								9-4	A4R22, A4R30	
P-H A453	5905-807-4954	RESISTOR, FIXED, COMPOSITION: RC07GF751J; 81349	ea	1				2	2	2	12	9-4	A4R23	
P-H A454	5905-683-7723	RESISTOR, FIXED, COMPOSITION: SAME AS A036	ea	1								9-4	A4R24	
P-H A455	5905-702-4439	RESISTOR, FIXED, COMPOSITION: RC070F133J; 81349	ea	1				*	*	2	3	9-4	A4R26	
P-H A456	5905-726-4413	RESISTOR, FIXED, COMPOSITION: SAME AS A027	ea	1								9-4	A4R27	
P-H A457	5905-682-4109	RESISTOR, FIXED, CO(POSITION: RCOT7CF56LJ; 81349	ea	2				2	2	3	18	9-4	A4R28, A4R29	
P-H A458	5905-686-3129	RESISTOR, FIXED, COMPOSITION: RC070F104J; 81349	ea	2				2	2	3	20	9-4	A4R31, A4R32	
P-H A459	5905-683-2243	RESISTOR, FIXED, COMPOSITION: RC70TGF151J; 81349	ea	1				2	2	3	2	9-4	A4R33	
P-H A460	5905-755-8389	RESISTOR, FIXED, COMPOSITION: RC070F220J; 81349	ea	1				2	2	2	9	9-4	A4R34	
P-H A461	5905-727-8001	RESISTOR, FIXED, COMPOSITION: SAME AS A408	ea	1								9-4	A4R36	
P-H A462	5905-682-410	RESISTOR, FIXED, COMPOSITION: RC070F1YJ; 81349	ea	1				*	2	2	6	9-4	A4R37	
P-H A463	5905-686-3370	RESISTOR, FIXED, COMPOSITION: SAME AS A025	ea	2								9-4	A4R38, AR400	
P-H A464	5905-801-8072	RESISTOR, FIXED, COMPOSITION: SAME AS A029	ea	1								9-4	A4R39	
P-H A465	5905-682-4097	RESISTOR, FIXED, COMPOSITION: SAME AS A272	ea	1								9-4	A4R4I	
P-H A466		CRYSTAL, QUARTZ: B4741; 03860	ea	1				*	*	*	2	9-4	A4YI	
A467		8000-DG1 91506												
X2-H A468		SCREW, PAN HEAD: SAME AS A047	ea	2										
X2-H A469	5310-595-6761	WASHER, FLAT: MS15795-302; 96906	ea	2										
X2-H A470	5310-543-4652	WASHER, LOCK: SAME AS A048	ea	2										
X2-H A471	5310-938-2013	NUT, HEXAGON SAME AS A0500	ea	2										
P-B A472	5935-852-2298	TEST JACK: 430-102; 83330	ea	1				2	2	2	19	10	9-4 AkTP1	
X2-H A473	03860	SHIELD: B4686;	ea	1										
X2-H A474	5305-059-8401	SCREW, PAN HEAD: SAME AS A190	ea	4										

**SECTION II REPAIR PARTS FOR DIRECT SUPPORT, GENERAL SUPPORT, AND DEPOT MAINTENANCE  
(CONTINUED)**

(1) SMR CODE	(2) FEDERAL STOCK NUMBER	(3) DESCRIPTION  USABLE ON CODE	(4) UNIT OF MEAS	(5) QTY INC IN UNIT	(6) 30 DAY DS MAINT ALLOWANCE			(7) 30 DAY GS MAINT ALLOWANCE			(8) 1-YR ALW PER EQUIP CNTGY	(9) DEPOT MAINT ALW PER 100 EQUIP	(10) ILLUS- TRATION	
					(a)	(b)	(c)	(a)	(b)	(c)			(a)	(b)
					1-20	21-50	51-100	1-20	21-50	51-100			FIG. NO.	ITEM NO./ REF DES
X2-H A475	5310-595-6211	WASHER, FLAT: SAME AS A097B	ea	4										
X2-H A476	5310-550-3715	WASHER, LOCK: SAME AS A097C	ea	4										
X2-H A477		NUT, HEXACON: SAME AS A142	ea	3										
X2-H A478		THERMAL CHAMBER: B4639; 03860	ea	1										
X2-H A479	5305-059-8449	SCREW, PAN HEAD: SAME AS A190	ea	4										
X2-H A480	5310-550-3715	WASHER, LOCK: SAME AS A097C	ea	4										
X2-H A481	5310-595-6211	WASHER, FLAT: SAME AS A097B	ea	4										
X2-H A482		NUT, HEXAGON: SAME AS A142	ea	4										
P-O-R A483	6625-771-0666	CIRCUIT CARD ASSEMBLY: C4705; 03860	ea	1				2	3	6	50	3	9-10	A14
P-H A485	5940-159-0245	TERMINAL: M817121-6; 96906	ea	2				2	2	2	20	10		
P-H A487AC	5905-892-6941	RESISTOR, FIXED, COMPOSITION: SAME AS A115	ea	3									9-10	A14R1, A14R19 A14R24 A1LR3
P-H A488	5905-686-9994	RESISTOR, FIXED, COMPOSITION: RC07GF122J; 81349	ea	1				2	2	3		20	9-10	A14R5, A1t4R39 A14R9, A14R29 A14R13
P-H A489	5905-683-2241	RESISTOR, FIXED, COMPOSITION: SAME AS A037	ea	2									9-10	A14R11, A14R44 AlbR56 A14R15
P-H A490	5905-686-3370	RESISTOR, FIXED, COMPOSITION: SAME AS A025	ea	2									9-10	A14R20
P-H A491	5905-752-3186	RESISTOR, FIXED, COMPOSITION: RC07F1163J; 81349	ea	1				*	2	2		6	9-10	A14R21, A114R58 A14R22, A1LR33 A14R23
P-H A492	5905-687-0002	RESISTOR, FIXED, COMPOSITION: RC07GF223J; 81349	ea	3				2	2	3		24	9-10	A14R25
P-H A493	5905-803-2908	RESISTOR, FIXED, COMPOSITION: SAME AS A450	ea	1									9-10	A14R27, A14Rb6 A14R28, A14R47 A14R17, A14R30 AlkR31, A14R48 A14R32, A14R49 A14R34
P-H A494	5905-681-9970	RESISTOR, FIXED, COMPOSITION: RC070F822J; 81349	ea	1				2	2	2		9	9-10	A14R41
P-H A495	5905-683-2246	RESISTOR, FIXED, COMPOSITION: RC07GF473J; 81349	ea	2				2	2	3		25	9-10	
P-H A496	5905-686-3903	RESISTOR, FIXED, COMPOSITION: RC07GF333J; 81349	ea	2				2	2	2		9	9-10	
P-H A497	5905-800-0179	RESISTOR, FIXED, COMPOSITION: RC07GF563J; 81349	ea	1				*	*	2		3	9-10	
P-H A498	5905-682-4098	RESISTOR, FIXED, COMPOSITION: SAME AS A028	ea	1									9-10	
P-H A499	5905-686-3129	RESISTOR, FIXED, COMPOSITION: SAME AS A458	ea	2									9-10	
P-H A500	5905-686-3356	RESISTOR, FIXED, COMPOSITION: RC070F823J; 81349	ea	2				2	2	2		10	9-10	
P-H AS01	5905-727-8001	RESISTOR, FIXED, COMPOSITION: SAME AS A408	ea	2									9-10	
P-H A502	5905-682-4097	RESISTOR, FIXED, COMPOSITION: SAME AS A272	ea	2									9-10	
P-H A503	5905-686-3122	RESISTOR, FIXED, COMPOSITION: RC07GF301J; 81349	ea	2				2	2	2		15	9-10	
P-H A504	5905-686-3128	RESISTOR, FIXED, COMPOSITION: RC007FI1YJ; 81349	ea	1				2	2	2		10	9-10	
P-H A505	5905-723-5251	RESISTOR, FIXED, COMPOSITION: SAME AS A267	ea	1									9-10	

**SECTION II REPAIR PARTS FOR DIRECT SUPPORT, GENERAL SUPPORT, AND DEPOT MAINTENANCE  
(CONTINUED)**

(1) SMR CODE	(2) FEDERAL STOCK NUMBER	(3) DESCRIPTION  USABLE ON CODE	(4) UNIT OF MEAS	(5) QTY INC IN UNIT	(6) 30 DAY DS MAINT ALLOWANCE			(7) 30 DAY GS MAINT ALLOWANCE			(8) 1-YR ALW PER EQUIP CNTGY	(9) DEPOT MAINT ALW PER 100 EQUIP	(10) ILLUS- TRATION	
					(a) 1-20	(b) 21-50	(c) 51-100	(a) 1-20	(b) 21-50	(c) 51-100			(a) FIG. NO.	(b) ITEM NO./ REF DES
P-H A506	5905-686-3358	RESISTOR, FIXED, COMPOSITION: SAME AS A026	ea	1								9-10	A14R35	
P-H A507	5905-682-4103	RESISTOR, FIXED, COMPOSITION: R07GF513J; 81349	ea	1				2	2	2		9	9-10	A14R36
P-H A508	5905-681-8818	RESISTOR, FIXED, COMPOSITION: SAME AS A264	ea	3									9-10	A14R37, AL14R42
P-H A509	5905-683-7724	RESISTOR, FIXED, COMPOSITION: RC07GF242J; 81349	ea	1				*	2	2		6	9-10	AL4R45 A14R38
P-H A5100	5905-682-4108	RESISTOR, FIXED, COMPOSITION: RC070F241J; 81349	ea	2				2	2	3		20	9-10	A14R4, A14R55
P-H A511	5905-683-7723	RESISTOR, FIXED, COMPOSITION: SAME AS A036	ea	1									9-10	A14R43
P-H A512	5905-683-7721	RESISTOR, FIXED, COMPOSITION: SAME AS A112	ea	1									9-10	A14R59
P-H A513	5905-681-6462	RESISTOR, FIXED, COMPOSITION: SAME AS A031	ea	2									9-10	A14R18, A14R26
P-H A514	5905-683-2242	RESISTOR, FIXED, COMPOSITION: RC07GF47EJ; 81349	ea	2				2	2	2		9	9-10	A4IR50, A14R54
P-H A515	5905-802-6730	RESISTOR, FIXED, COMPOSITION: SAME AS A445	ea	1									9-10	A14R51
P-H A516	5905-686-3369	RESISTOR, FIXED, COMPOSITION: RC07GF331J; 81349	ea	1				*	*	2		3	9-10	A14R52
P-H A517	5905-688-3738	RESISTOR, FIXED, COMPOSITION: SAME AS A271	ea	1									9-10	A14R53
P-H A518	5905-683-2238	RESISTOR, FIXED, COMPOSITION: SAME AS A298	ea	1									9-10	AA14R57
P-H A519	5910-904-8488	CAPACITOR, FIXED,	ea	3									9-10	A14C2, A14C22 A14C24
P-H A520	5910-087-3468	ELECTROLYTIC: SAME AS A012 CAPACITOR, FIXED, MICA:	ea	1				*	*	2		3	9-10	A14C32
P-H A521	CM05F101J03	81349 CAPACITOR, FIXED, CERAMIC: CK63AX1003M; 81349 (ITEM NO A14C4, A14C6, A14C8, A14C9, A14C12, A14C15, A14C17, A14C21, A14C23, A14C25)	ea	10				2	3	4		36	9-10	(See Des. Column).
P-H A522	5910-577-n194	CAPACITOR, FIXED, MICA: CM05F181J03; 81349	ea	2				*	2	2		6	9-10	A14C7, A14C18
P-H A523	5910-056-7976	CAPACITOR, FIXED, MICA: CM05F271G03; 81349	ea	1				*	*	2		3	9-10	A14C10
P-H A524		CAPACITOR, FIXED, MICA: CM05F390G03; 81349	ea	2				*	2	2		6	9-10	A14C3, A14C01
P-H A525	5910-957-9908	CAPACITOR, FIXED, MICA: CM06F511CO3; 81349	ea	1				*	*	2		3	9-10	A14C13
P-H A526		CAPACITOR, FIXED, MICA: CM05F120KO3; 81349	ea	1				*	*	2		3	9-10	A14C14
P-H A527	5910-989-6427	CAPACITOR, FIXED, MICA: MOS5F301G03; 81349	ea	1				*	*	2		3	9-10	A14C16
P-H A528	5910-995-0614	CAPACITOR, FIXED, MICA: CM405F221G03; 81349	ea	2				2	2	2		10	9-10	A14C19, A14C27
P-H A529	5910-835-2735	CAPACITOR, FIXED, MICA:	ea	5									9-10	A14C20, A14C28 thru A14C31
P-H A530	5910-954-5505	SAME AS A102 CAPACITOR, FIXED, MICA: CM05F111G03; 81349	ea	1				*	2	3			9-10	A14C26
P-H A531	5961-892-8706	TRANSISTOR:  SAME AS A035 (ITEM NO. AA14Q1, A14Q3, AL4q5, A14Q7 thru A14Q11, A14q13, A14114, A411Q15, A41Q17, A11Q18)	ea	13									9-10	(See Des. Column)

**SECTION II REPAIR PARTS FOR DIRECT SUPPORT, GENERAL SUPPORT, AND DEPOT MAINTENANCE**

**(CONTINUED)**

(1) SMR CODE  INDEX NO.	(2)  FEDERAL STOCK NUMBER	(3) DESCRIPTION  USABLE ON CODE  REF. NUMBER & MFR CODE	(4) UNIT OF MEAS	(5) QTY INC IN UNIT	(6) 30 DAY DS MAINT ALLOWANCE			(7) 30 DAY GS MAINT ALLOWANCE			(8) 1-YR ALW PER EQUIP CNTGY	(9) DEPOT MAINT ALW PER 100 EQUIP	(10) ILLUS- TRATION	
					(a)	(b)	(c)	(a)	(b)	(c)			(a)	(b)
					1-20	21-50	51-100	1-20	21-50	51-100			FIG. NO.	ITEM NO./ REF DES
P-H A532	5961-072-0128	TRANSISTOR: SAME AS A287	ea	2								9-10	A1402, L14016	
P-H A533	5961-842-9864	SEMICONDUCTOR, DEVICE, DIODE: SAME AS AO15	ea	1								9-10	A14CR1	
P-H A534		INDUCTOR, VARIABLE: SAME AS A430	ea	2								9-10	A14L1, A14L4	
P-H A535	3360-43; 71279	INDUCTOR, VARIABLE:	ea	2				*	2	2		6	9-10	A14L2, A14L3
P-H A536	5961-556-2091	SEMICONDUCTOR, DEVICE, DIODE: IN270; 81349	ea	1				2	2	2		18	9-10	A14CR2
X2-H A537		SHIELD BOX: B4683; 03860	ea	1										
X2-H A538	5305-054-5647	SCREW, PAN HEAD: SAME AS A290	ea	4										
X2-H A539		NRT, HEXAGON: SAME AS A142	ea	4										
X2-H A540	5310-550-3715	WASHER, LOCK: SAME AS A097C	ea	4										
X2-H A541	5310-595-6211	WASHER, FLAT: SAME AS AO9T7B	ea	4										
P-H A541L		INDUCTOR: MS90538-19; 81349	ea	1				*	*	2		3	9-10	A14L5
P-O-F A542	6625-717-7461	CIRCUIT CARD ASSEMBLY: C4706; 03860	ea	1				2	3	6	45	3	9-12	A15
P-H A546	5940-159-0245	TERMINAL: SAME AS A485	ea	2										
P-H A547	5905-892-6941	RESISTOR, FIXED, COMPOSITION: SAME AS A115	ea	3									9-12	A15R1, A15R19 A15R24
P-H A547A	5905-686-9994	RESISTOR, FIXED, COMPOSITION: SAME AS A488	ea	1									9-12	A15R3
P-H A547B	5905-683-2241	RESISTOR, FIXED, COMPOSITION: SAME AS A037	ea	2									9-12	A15R5, A15R39
P-H A547C	5905-686-3370	RESISTOR, FIXED, COMPOSITION: SAME AS A025	ea	2									9-12	A15R9, A15R29
P-H A548	5905-752-3186	RESISTOR, FIXED, COMPOSITION: SAME AS A491	ea	1									9-12	A15R13
P-H A549	5905-687-0002	RESISTOR, FIXED, COMPOSITION: SAME AS A492	ea	3									9-12	A15R14, A15R44 A15R56
P-H A550	5905-803-2908	RESISTOR, FIXED, COMPOSITION: SAME AS A450	ea	1									9-12	A15R15
P-H A551	5905-681-9970	RESISTOR, FIXED, COMPOSITION: SAME AS A494	ea	1									9-12	A15R20
P-H A552	5905-683-2246	RESISTOR, FIXED, COMPOSITION: SAME AS A495	ea	2									9-12	A15R21, A15R58
P-H A553	5905-686-3903	RESISTOR, FIXED, COMPOSITION: SAME AS A496	ea	1									9-12	A15R22
P-H A554	5905-800-0179	RESISTOR, FIXED, COMPOSITION: SAME AS A497	ea	2									9-12	A15R23, A15R59
P-H A555	5905-682-4098	RESISTOR, FIXED, COMPOSITION: SAME AS A028	ea	1									9-12	A15R25
P-H A15R46	5905-686-3129	RESISTOR, FIXED, COMPOSITION: SAME AS A458	ea	2									9-12	A15R27,
P-H A557	5905-686-3356	RESISTOR, FIXED, COMPOSITION: SAME AS A500	ea	2									9-12	A15R28, A15R47
P-H A558	5905-727-8001	RESISTOR, FIXED, COMPOSITION: SAME AS A408	ea	2									9-12	A15R17, A15R30

**SECTION II REPAIR PARTS FOR DIRECT SUPPORT, GENERAL SUPPORT, AND DEPOT MAINTENANCE  
(CONTINUED)**

(1) SMR CODE	(2) FEDERAL STOCK NUMBER	(3) DESCRIPTION  USABLE ON CODE	(4) UNIT OF MEAS	(5) QTY INC IN UNIT	(6) 30 DAY DS MAINT ALLOWANCE			(7) 30 DAY GS MAINT ALLOWANCE			(8) 1-YR ALW PER EQUIP CNTGY	(9) DEPOT MAINT ALW PER 100 EQUIP	(10) ILLUS- TRATION	
					(a)	(b)	(c)	(a)	(b)	(c)			(a)	(b)
					1-20	21-50	51-100	1-20	21-50	51-100			FIG. NO.	ITEM NO./ REF DES.
P-H A559	5905-682-4097	RESISTOR, FIXED, COMPOSITION: SAME AS A272	ea	2								9-12	A15R31, A15R48	
P-H A560	5905-686-3122	RESISTOR, FIXED, COMPOSITION: SAME AS A503	ea	2								9-12	A15R32, A15R49	
P-H A561	5905-686-3358	RESISTOR, FIXED, COMPOSITION: SAME AS A026	ea	1								9-12	A15R35	
P-H A562	5905-682-4103	RESISTOR, FIXED, COMPOSITION: SAME AS A507	ea	1								9-12	A15R36	
P-H A563	5905-681-8818	RESISTOR, FIXED, COMPOSITION: SAME AS A264	ea	3								9-12	A15R37, A15R42 A15R45	
P-H A564	5905-683-7724	RESISTOR, FIXED, COMPOSITION: SAME AS A509	es	1								9-12	A15R38	
P-H A565	5905-805-9713	RESISTOR, FIXED, COMPOSITION: RC070F43LJ; 81349	ea	2				2	2		6	9-12	A15R40, A15R50	
P-H A566	5905-683-7723	RESISTOR, FIXED, COMPOSITION: SAME AS A036	ea	1								9-12	A15R43	
P-H A567	5905-681-6462	RESISTOR, FIXED, COMPOSITION: SAME AS A031	ea	2								9-12	A15R18, A15R26	
P-H A568	5905-683-2242	RESISTOR, FIXED, COMPOSITION: SAME AS A514	ea	1								9-12	A15R54	
P-H A569	5905-802-6730	RESISTOR, FIXED, COCPOSITION: SAME AS A445	ea	1								9-12	A15R51	
P-H A570	5905-801-6444	RESISTOR, FIXED, COMPOSITION: SAME AS A409	ea	1								9-12	A15R52	
P-H A571	5905-688-3738	RESISTOR, FIXED, COMPOSITION: SAME AS A271	ea	1								9-12	A15R53	
P-H A572	5905-682-4108	RESISTOR, FIXED, COMPOSITION: SAME AS A510	ea	1								9-12	A15R55	
P-H A573	5905-683-2238	RESISTOR, FIXED, COMPOSITION: SAME AS A298	ea	1								9-12	A15R57	
P-H A574	5910-904-8488	CAPACITOR, FIXED, ELECTROLYTIC: SAME AS A012	ea	2								9-12	A15C2, A15C24	
P-H A575	5910-995-0614	CAPACITOR, FIXED, MICA: SAME AS A528	ea	2								9-12	A15C19, A15C27	
P-H A576	5910-835-2735	CAPACITOR, FIXED, MICA: SAME AS A102 (ITOI NO. A15C3, A15C4, A15C6, A15C8, A15C9, A15C12, A15C15, A15C17, A15C20, A15C25)	ea	10								9-12	(See Des. Column)	
P-H A577	5910-724-5523	CAPACITOR, FIXED, MICA: CM06F13203; 81349	ea	2				*	2	2	6	9-12	A15C7, A15C18	
P-H A578	5910-045-5434	CAPACITOR, FIXED, MICA: CM06F272003; 81349	ea	1				*	*	2	3	9-12	A15C10	
P-H A579	5910-957-9909	CAPACITOR, FIXED, MICA: CMOSF391103; 81349	ea	1				*	*	2	3	9-12	A15C11	
P-H A580	5910-082-4898	CAPACITOR, FIXED, MICA: CM06F242603; 81349	ea	1				*	*	2	3	9-12	A15C13	
P-H A581	5910-954-5500	CAPACITOR, FIXED, MICA: SAME AS A422	ea	1								9-12	A15C11	
P-H A582	5910-781-4511	CAPACITOR, FIXED, MICA: OM06F302003; 81349	ea	1				*	*	2	3	9-12	A15C16	
P-H A583	5910-965-9441	CAPACITOR, FIXED, MICA: CM06F102003; 81349	ea	1				*	*	2	3	9-12	A15C26	
P-H A584	5910-082-4898	CAPACITOR, FIXED, ELECTROLYTIC: CS13BC107K; 81349	es	1				*	*	2	3	9-12	A15C23	
P-H A585	5961-892-8706	TRANSISTOR:  SAME AS A035 (ITEM 10. A15Q1, A15Q3, AL5, A15Q7 thru A15Q11, A15Q13, A15Q14, A15Q15, A15Q17, A15Q18)	ea	13								9-12	(See Des. Column)	

**SECTION IV. REPAIR PARTS FOR DIRECT SUPPORT, GENERAL SUPPORT, AND DEPOT MAINTENANCE  
(CONTINUED)**

(1) SMR CODE	(2) FEDERAL STOCK NUMBER	(3) DESCRIPTION  USABLE ON CODE	(4) UNIT OF MEAS	(5) QTY INC IN UNIT	(6) 30 DAY DS MAINT			(7) 30 DAY GS MAINT			(8) 1-YR ALW PER EQUIP CNTGY	(9) DEPOT MAINT ALW PER 100 EQUIP	(a) FIG. NO.	(10) ILLUS- TRATION  (b) ITEM NO./ REF DES
					ALLOWANCE	ALLOWANCE	ALLOWANCE	ALLOWANCE	ALLOWANCE	ALLOWANCE				
					(a) 1-20	(b) 21-50	(c) 51-100	(a) 1-20	(b) 21-50	(c) 51-100				
P-H A586	5961-072-0128	TRANSISTOR: SAME AS A287	ea	2								9-12	A15Q12, A15Q16	
P-H A587	5961-842-9864	SEMICONDUCTOR, DEVICE, DIODE: SAME AS A015	ea	1								9-12	A15CR1	
P-H A15L4 A588		INDUCTOR, VARIABLE: 3370-24; 71279	ea	2				*	2	2		6	9-12 A15L1,	
P-H A589		INDUCTOR: B4626-1; 03860	ea	1				*	*	2		3	9-12 A15L2	
P-H A590		INDUCTOR: B4626-2; 03860	ea	1				*	*	2		3	9-12 A15L3	
P-H A591	5905-686-3128	RESISTOR, FIXED, COMPOSITION: SAME AS A504	ea	1								9-12	A15R60	
X2-H A592		SHIELD, BOX: B4682; 03860	ea	1										
X2-D A595		DIVIDER: A4810; 03860	ea	1										
X2-H A596		SCREW, FLAT HEAD: HM51959-13; 96906	ea	2										
X2-H A596A	5310-722-5998	WASHER, FLAT: SAME AS A045	ea	4										
X2-H A596B		WASHER, LOCK: MS35338-136; 96906	ea	4										
X2-H A596C		NUT, HEXAGON: SAME AS A085	ea	4										
X2-H A596D	5305-054-5648	SCREW, PAN HEAD: SAME AS A087	ea	2										
X2-H A596E	5310-595-6211	WASHER, FLAT: SAME AS A097B	e-	2										
X2-H A596F	5310-550-3715	WASHER, LOCK: SAME AS A097C	ea	2										
P-O-R A597	6625-717-7458	CIRCUIT CARD ASSEMBLY: C4707; 03860	ea	1				2	3	5	45	3	9-8 A16	
P-H A599	5905-686-3370	RESISTOR, FIXED, COMPOSITION SAME AS A025	ea	2								9-8	A16R2, A16R47	
P-H A600	5905-683-2241	RESISTOR, FIXED, COMPOSITION: SAME AS A037	ea	5								9-8	A16R16, A16R23 A16R34, A16R41 A16R44	
P-H A601	5905-689-9608	RESISTOR, VARIABLE: RT12C2P1C3; 81349	ea	1	2	2	2					10	9-8 A16R4	
P-H A602	5905-683-2238	RESISTOR, FIXED, COMPOSITION: SAME AS A298	ea	3								9-8	A16R21, A16R28 A16R46	
P-H A603	5905-683-7723	RESISTOR, FIXED, COMPOSITION: SAME AS A036	ea	2								9-8	A16R7, A16R8	
P-H A604	5905-682-4099	RESISTOR, FIXED, COMPOSITION: RC07GF432J; 81349	ea	5				2	2	3		20	9-8 A16R9, A16R13 A16R17, A16R24 A16R32	
P-H A605	5905-681-6462	RESISTOR, FIXED, COMPOSITION: SAME AS A031 (ITEM NO. A16R10, A16R18, A16R30, A16R35, A16R38, A16R39, A16R42)	ea	7								9-8	(See Des. Column)	
P-H A606	5905-691-0195	RESISTOR, FIXED, COMPOSITION: SAME AS A365	ea	1								9-8	A16R11	
P-H A607	5905-801-6444	RESISTOR, FIXED, COMPOSITION: SAME AS A409	ea	1								9-8	A16R12	
P-H A608	5905-688-3738	RESISTOR, FIXED, COMPOSITION: SAME AS A271	ea	2								9-8	A16R14, A16R29	
P-H A609	5905-681-9669	RESISTOR, FIXED, COMPOSITION: SAME AS A030	ea	1								9-8	A16R15	



**SECTION IV. REPAIR PARTS FOR DIRECT SUPPORT, GENERAL SUPPORT, AND DEPOT MAINTENANCE  
(CONTINUED)**

(1) SMR CODE	(2) FEDERAL STOCK NUMBER	(3) DESCRIPTION  USABLE ON CODE	(4) UNIT OF MEAS	(5) QTY INC IN UNIT	(6) 30 DAY DS MAINT ALLOWANCE			(7) 30 DAY GS MAINT ALLOWANCE			(8) 1-YR ALW PER EQUIP CNTGY	(9) DEPOT MAINT ALW PER 100 EQUIP	(a) FIG. NO.	(10) ILLUS- TRATION  (b) ITEM NO./ REF DES
					(a)	(b)	(c)	(a)	(b)	(c)				
					1-20	21-50	51-100	1-20	21-50	51-100				
P-H A610	5905-682-4097	RESISTOR, FIXED, COMPOSITION: SAME AS A272	ea	3								9-8	A16R29, A16R20 A16R25	
P-H A611	5905-686-9994	RESISTOR, FIXED, COMPOSITION: SAME AS A488	ea	2								9-8	A16R22, A16R36	
P-H A612	5905-686-3798	RESISTOR, FIXED, COMPOSITION: RC07GF272J; 81349	ea	1				2	2	2		9	9-8 A16R26	
P-H A613	5905-686-3128	RESISTOR, FIXED, COMPOSITION: SAME AS A504	ea	1								9-8	A16R27	
P-H A614	5905-686-3368	RESISTOR, FIXED, COMPOSITION: SAME AS A110	ea	1								9-8	A16R31	
P-H A615	5905-682-3095	RESISTOR, FIXED, COMPOSITION: RC07GF162J; 81349	ea	1	.	.		*	*	2		3	9-8 A16R33	
P-H A616	5905-682-h083	RESISTOR, FIXED, COMPOSITION: RC07GF111J; 81349	ea	1	.	.		*	*	.2		3	9-8 A16R37	
P-H A617	5905-686-9998	RESISTOR, FIXED, COMPOSITION: SAME AS A444	ea	2								9-8	A16R40, A16R43	
P-H A618	5905-686-3129	RESISTOR, FIXED, COMPOSITION: SAME AS A458	ea	1								9-8	A16R45	
P-H A619	5905-723-5251	RESISTOR, FIXED, COMPOSITION: SAME AS A267	ea	2								9-8	A16R48, A16R49	
P-H A620	5910-9084-888	CAPACITOR, FIXED, ELECTROLYTIC: SAME AS A012	ea	3								9-8	A16C1, A16C3, A16 C7	
P-H A621	5910-060-1194	CAPACITOR, FIXED, MICA: CM06F102J03; 81349	ea	1				*	*	2		3	9-8 A16C2	
P-H A622	5910-822-5683	CAPACITOR, FIXED, CERAMIC: SAME AS A032	ea	2								9-8	A16C4, A16C9	
P-H A623	5910-835-2711	CAPACITOR, FIXED, PLASTIC: SAME AS A382	ea	1								9-8	A16C5	
P-H A624		CAPACITOR, FIXED, MICA: CM05F390J03; 81349	ea	1	.	.		*	2	2		6	9-8 A16C6	
P-H A625		CAPACITOR: 109D128X9006W2; 56289	ea	1	*	*		*	*	2		3	9-8 A16C8	
P-H A626	5961-842-9864	SEMICONDUCTOR, DEVICE, DIODE: SAME AS A015	ea	4								9-8	A16CR1 thru A16CR4	
P-H A627		INTEGRATED CIRCUIT: SAME AS A017	ea	1								9-8	A16M1	
P-H A628		INTEGRATED CIRCUIT: SN7473N; 01295	ea	1	.	.		*	*	.2		3	9-8 A16M2	
P-H A629	5961-892-8706	TRANSISTOR: SAME AS A035	ea	6								9-8	A16Q1, A16Q3 A16Q6, A16Q12 A16Q14 A16Q16	
P-H A630	5961-072-0128	TRANSISTOR: SAME AS A287	ea	9								9-8	A16Q2, A16Q4 A16Q5, A16Q7 thru A16Q11 A16Q15	
P-H A631	5935-852-2298	TEST JACK: SAME AS A472	ea	3								9-8	A16TP1, A16TP2 A16TP3	
P-H A631A	5905-752-3973	RESISTOR, FIXED, FILM: RN65C2001F; 81349	ea	1	.	.		*	2	2		6	9-8 A16R1	
P-H A631B	5905-806-4599	RESISTOR, FIXED, FILM: R65C5111F; 81349	ea	2	.	.		*	2	2		6	9-8 A16R3, A16R6	
P-H A631C	5905-682-0214	RESISTOR, FIXED, FILM: RN65C1002F; 81349	ea	1	.	.		*	*	2		3	9-8 A16R5	
P-H A631D	5905-807-4954	RESISTOR, FIXED, COMPOSITION: SAME AS A453	ea	1								9-8	A16R50	
P-H A631E	5910-835-2958	CAPACITOR, FIXED, MICA: CTM154VBK; 81349	ea	1	.	.		*	*	2		3	9-8 A16C10	
P-O-F A632	6625-771-0863	CIRCUIT CARD ASSEMBLY: C4704; 03860	ea	1				2	3	6	45	3	9-19 A12	

**SECTION IV. REPAIR PARTS FOR DIRECT SUPPORT, GENERAL SUPPORT, AND DEPOT MAINTENANCE  
(CONTINUED)**

(1) SMR CODE	(2) FEDERAL STOCK NUMBER	(3) DESCRIPTION  USABLE ON CODE	(4) UNIT OF MEAS	(5) QTY INC IN UNIT	(6) 30 DAY DS MAINT ALLOWANCE			(7) 30 DAY GS MAINT ALLOWANCE			(8) 1-YR ALW PER EQUIP CNTGY	(9) DEPOT MAINT ALW PER 100 EQUIP	(a) FIG. NO.	(10) ILLUS- TRATION  (b) ITEM NO./ REF DES
					(a)	(b)	(c)	(a)	(b)	(c)				
					1-20	21-50	51-100	1-20	21-50	51-100				
P-H A633C	5905-835-1631	RESISTOR, FIXED, COMPOSITION: RC07CF200J; 81349	ea	1				2	2	2		9	9-19 A12R23	
P-H A634	5905-723-5251	RESISTOR, FIXED, COMPOSITION: SAME AS A267 (ITEM NO. A12R1, A12R2, A12R39, A12R42, A12R44, A12R45, A2R46, A1L2R52, A12R61, A12R64)	ea	10								9-19	(See Des. Column)	
P-H A635	5905-686-9994	RESISTOR, FIXED, COMPOSITION: SAME AS A488	ea	2								9-19	A12R3,A12R8	
P-H A636	5905-727-8001	RESISTOR, FIXED, COMPOSITION: SAME AS A408	ea	1								9-19	A12R4	
P-H A637	5905-683-2238	RESISTOR, FIXED, COMPOSITION: SAME AS A298	ea	4								9-19	A12R5, A12R17 A12R31, A12R32	
P-H A638	5905-752-3955	RESISTOR, FIXED, FILM: R065C9090F; 81349	ea	1				*	*	2		3	9-19 A12R6	
P-H A639	5905-802-6730	RESISTOR, FIXED, COMPOSITION: SAME AS A445	ea	1								9-19	A12R7	
P-H A640	5905-689-6799	RESISTOR, VARIABLE, TRM POT: SAME AS A299	a	3								9-19	A12R9, A12R16 A12R36	
P-H A641	5905-686-9996	RESISTOR, FIXED, COMPOSITION: SAME AS A371	ea	1								9-19	A12R10	
P-H A642	5905-892-6941	RESISTOR, FIXED, COMPOSITION: SAME AS A115	ea	5								9-19	A12R11, A12R21 A12R22, A12R53 A12R54 A12R12	
P-H A643	5905-687-0002	RESISTOR, FIXED, COMPOSITION: SAME AS A492	ea	1								9-19	A12R12	
P-H A644	5905-682-4105	RESISTOR, FIXED, COMPOSITION: RC0T7F224J; 81349	ea	1				*	*	2		3	9-19 A12R13	
P-H A645	5905-686-3122	RESISTOR, FIXED, COMPOSITION: SAME AS A503	ea	1								9-19	A12R14	
P-H A646	5905-061-5355	RESISTOR, FIXED, FILM: RN65C9091F; 81349	ea	1				*	*	2		3	9-19 A12R15	
P-H A647	5905-683-2235	RESISTOR, FIXED, COMPOSITION: RC07GF680J; 81349	a	2				*	2	2		6	9-19 A12R18,A12R19	
P-H A648	5905-681-9969	RESISTOR, FIXED, COMPOSITION: SAME AS A030	ea	1								9-19	A12R20	
P-H A649	5905-817-7971	RESISTOR, FIXED, COMPOSITION: RC07GF100J; 81349	ea	4				2	2	3		20	9-19 A12R24,A12R25 A12R55,A12R56	
P-H A650	5905-827-4815	RESISTOR, FIXED, FILM: RN65C3012F; 81349	ea	1				*	*	2		3	9-19 A12R26	
P-H A651	5905-702-8755	RESISTOR, FIXED, FILM: RN65C1000F; 81349	ea	1				*	*	2		3	9-19 A12R27	
P-H A652	5905-752-6715	RESISTOR, FIXED, FILM: RN65C2000F; 81349	ea	3				2	2	2		18	9-19 A12R28, A12R29 A12R57	
P-H A653	5905-683-2241	RESISTOR, FIXED, COMPOSITION: SAME AS A037	ea	2								9-19	A12R30,A12R38	
P-H A655	5905-752-3957	RESISTOR, FIXED, FILM: RN65C1212F; 81349	ea	1				*	*	2		3	9-19 A12R33	
P-H A656	5905-683-2243	RESISTOR, FIXED, COMPOSITION: SAME AS A459	ea	2								9-19	A12R34,A12R35	
P-H A657	5905-978-7274	RESISTOR, FIXED, FILM: RN65C2802F; 81349	ea	1				*	*	2		3	9-19 A12R37	
P-H A658	5905-801-2377	RESISTOR, FIXED, COMPOSITION: RC07GF750J; 81349	ea	2				*	2	2		6	9-19 A12R40, A12R43	
P-H A659	5905-686-3119	RESISTOR, FIXED, COMPOSITION: RC07GF132J; 81349	ea	1				*	*	2		3	9-19 A12R41	
P-H A660	5905-682-4098	RESISTOR, FIXED, COMPOSITION: SAME AS A028	ea	1								9-19	A12R47	

D29

**SECTION IV. REPAIR PARTS FOR DIRECT SUPPORT, GENERAL SUPPORT, AND DEPOT MAINTENANCE  
(CONTINUED)**

(1) SMR CODE	(2) FEDERAL STOCK NUMBER	(3) DESCRIPTION  USABLE ON CODE	(4) UNIT OF MEAS	(5) QTY INC IN UNIT	(6) 30 DAY DS MAINT			(7) 30 DAY GS MAINT			(8) 1-YR ALW PER EQUIP CNTGY	(9) DEPOT MAINT ALW PER 100 EQUIP	(a) FIG. NO.	(10) ILLUS- TRATION  (b) ITEM NO./ REF DES
					ALLOWANCE	ALLOWANCE	ALLOWANCE	ALLOWANCE	ALLOWANCE	ALLOWANCE				
					(a) 1-20	(b) 21-50	(c) 51-100	(a) 1-20	(b) 21-50	(c) 51-100				
P-H A661	5905-682-4103	RESISTOR, FIXED, COMPOSITION: SAME AS 507	ea	1								9-19	A12R48	
P-H A662	5905-755-8389	RESISTOR, FIXED, COMPOSITION: SAME AS A460	ea	2								9-19	A12R49, A12R51	
P-H A663	5905-682-4108	RESISTOR, FIXED, COMPOSITION: SAME AS A510	ea	1								9-19	A12R50	
P-H A664	5905-683-7721	RESISTOR, FIXED, COMPOSITION: SAME AS A112 (ITEM NO. A12R58, A12R59, A12R60, A12R62, A12R63, A12R65, A12R66, A12R67)	ea	8								9-1	(See Des. Column)	
P-H A665	5910-709-0343	CAPACITOR, FIXED, ELECTROLYTIC: CELLC150F; 81349	ea	1			*	*	2			3	9-19	A12C1
P-H A666	5910-171-8970	CAPACITOR, FIXED, TANTALUM: CS13BB337K; 81349	ea	1			2	2	2			18	9-19	A12C2
P-H A667	5910-904-8488	CAPACITOR, FIXED, ELECTROLYTIC: SAME AS A012	ea	5								9-19	A12C3, A12C16 A12C19, A12C20 A12C21	
P-H A668	5910-952-6432	CAPACITOR, FIXED, MICA: CM06F561J03; 81349	ea	1			*	2	2			6	9-19	A12C4
P-H A669	5910-822-5683	CAPACITOR, FIXED, CERAMIC: SAME AS A032 (ITEM NO. A12C5, A12C6, A12C10, A12C14, A12C17, A12C18, A12C24, A12C25)	ea	8								9-19	(See Des. Column)	
P-H A670	5910-926-0048	CAPACITOR, FIXED, MICA: SAME AS A420	ea	2								9-19	A12CSA12C15	
P-H A671	5910-926-0048	CAPACITOR, FIXED, ELECTROLYTIC: CE11C350D; 81349	ea	3			2	2	2			15	9-19	A12C9, A12 A12C13
P-H A672	5910-847-7288	CAPACITOR, FIXED, MICA: CK06CW103K; 81349	ea	1			*	*	2			3	9-19	A12C11
P-H A673		CAPACITOR, FIXED, MICA: SAME AS A624	ea	1								9-19	A12C23	
P-H A674	5961-556-2091	SEMICONDUCTOR, DEVICE, DIODE: SAME AS A536	ea	1								9-19	A12CR1	
P-H A675	5961-842-9864	SEMICONDUCTOR, DEVICE, DIODE:	ea	10								9-19	A12CR3 thru A12CR12	
P-H A676	5961-752-6121	SAME AS A15 SEMICONDUCTOR, DEVICE, DIODE: SAME AS A390B	ea	1								9-19	A12CR2	
P-H A677	5910-834-9765	CAPACITOR, FIXED, MICA: CTM474VAK; 81349	ea	1			*	*	2			3	9-19	A12C7
P-H A678	5961-892-8706	TRANSISTOR: SAME AS A035	ea	8								9-19	A12Q1 thru A12Q4 A12A6, A12Q7, A12Q8, A12Q11	
P-H A679	5961-072-0128	TRANSISTOR: SAME AS A287	ea	4								9-19	A12Q5, A12Q9 A12Q10, A12Q12	
P-H A680		AMPLIFIER, VA702C: PA771239; 82726	ea	2			2	2	2	27		15	9-19	A12A1, A12A2
P-O-R A681	6625-771-0860	CIRCUIT CARD ASSEMBLY: C4698; 03860	ea	1			2	3	4	50		3	9-17	A6
P-H A682A	5940-271-4030	TEERMINAL: SAME AS A261	ea	2								9-17		
P-H A683	5905-752-3602	RESISTOR, FIXED, FILM SAME AS A377	ea	2								9-17	A6R1, A6R6	
P-H A684	5905-835-1631	RESISTOR, FIXED, COMPOSITION: SAME AS A633C	ea	1								9-17	A6R2	
P-H A685	5905-061-4017	RESISTOR, FIXED, FILM: R165C4022F; 81349	ea	1			*	*	2			3	9-17	A6R3
P-H A686	5905-686-3370	RESISTOR, FIXED, COMPOSITION: SAME AS A025	ea	1								9-17	A6R4	

**SECTION IV. REPAIR PARTS FOR DIRECT SUPPORT, GENERAL SUPPORT, AND DEPOT MAINTENANCE  
(CONTINUED)**

(1) SMR CODE	(2) FEDERAL STOCK NUMBER	(3) DESCRIPTION  USABLE ON CODE	(4) UNIT OF MEAS	(5) QTY INC IN UNIT	(6) 30 DAY DS MAINT ALLOWANCE			(7) 30 DAY GS MAINT ALLOWANCE			(8) 1-YR ALW PER EQUIP CNTGY	(9) DEPOT MAINT ALW PER 100 EQUIP	(a) FIG. NO.	(10) ILLUS- TRATION  (b) ITEM NO./ REF DES
					(a)	(b)	(c)	(a)	(b)	(c)				
					1-20	21-50	51-100	1-20	21-50	51-100				
P-H A687	5905-683-2241	RESISTOR, FIXED, COMPOSITION: SAME AS A037	ea	4								9-17	A6R5, A6R12	
P-H A688		RESISTOR, FIXED, FILM: RR65C2942F; 81349	ea	1				*	*	2		9-17	A6R36, A6R37 A6R7	
P-H A689	5905-686-3122	RESISTOR, FIXED, COMPOSITION: SAME AS A503	ea	1								9-17	A6R8	
P-H A690	5905-689-6799	RESISTOR, VARIABLE, TRIM POT: SAME AS A299	ea	1								9-17	A6R9	
P-H A691	5905-801-6444	RESISTOR, FIXED, COMPOSITION: SAME AS A409	ea	1								9-17	A6R10	
P-H A692	5905-682-4108	RESISTOR, FIXED, COMPOSITION: SAME AS A510	ea	1								9-17	A6Ru	
P-H A693 A6R19	5905-723-5251	RESISTOR, FIXED, COMPOSITION: SAME AS A267	ea	8								9-17	A6R13, A6R15 A6516, A6R27,	
A6R30													A6R32, A6R34 A6R14	
P-H A694	5905-687-0002	RESISTOR, FIXED, COMPOSITION: SAME AS A492	ea	1								9-17	A6R17, A6R18 A6R21,	
P-H A695 A6R31	5905-682-4109	RESISTOR, FIXED, COMPOSITION: SAME AS A457	ea	4								9-17	A6R21,	
P-H A696	5905-687-0000	RESISTOR, FIXED, COMPOSITION: RC07GF183J; 81349	ea	1					2	2		9-17	A6R38	
P-H A697	5905-892-6941	RESISTOR, FIXED, COMPOSITION: SAME AS A15	ea	2								9-17	A6R20, A6R35	
P-H A698	5905-681-9969	RESISTOR, FIXED, COMPOSITION: SAME AS A030	ea	2								9-17	A6R22, A6R23	
P-H A699	5905-681-6462	RESISTOR, FIXED, COMPOSITION: SAME AS A031	ea	1								9-17	A6R24	
P-H A700	5905-683-2243	RESISTOR, FIXED, COMPOSITION: SAME AS A459	ea	4								9-17	A6R25, A6R26	
A6R28, A6R29														
P-H A701	5905-682-4110	RESISTOR, FIXED, COMPOSITION: SAME AS A462	ea	1								9-17	A6R39	
P-H A702	5905-752-6715	RESISTOR, FIXED, FILM: SAME AS A652	ea	1								9-17	A6R33	
P-H A703	5910-904-8488	CAPACITOR, FIXED, ELECTROLYTIC: SAME AS A012	ea	2								9-17	A6C2, A6C6	
P-H A704 A6C10	5910-822-5683	CAPACITOR, FIXED, CERAMIC: SAME AS A032	ea	4								9-17	A6C3, A6C5 A6C9,	
P-H A705	5910-717-5853	CAPACITOR, FIXED, MICA: CH06F182J03; 81349	ea	1				*	*	2		9-17	A6C4	
P-H A706	5910-943-9340	CAPACITOR, FIXED, ELECTROLYTIC: CE11C250E; 81349	ea	1				*	2	2		9-17	A6C7	
P-H A707	5910-952-6432	CAPACITOR, FIXED, MICA: SAME AS A668	ea	1								9-17	A6C8	
P-H A708		CAPACITOR, FIXED, MICA: SAME AS A420	ea	1								9-17	A6C11	
P-H A709		CAPACITOR, FIXED, MYLAR: SAME AS A278	ea	1								9-17	A6C13	
P-H A710	5961-752-6121	SEMICONDUCTOR DEVICE, DIODE, SAME AS A390B	ea	1								9-17	A6CR1	
P-H A711	5961-556-2091	SEMICONDUCTOR DEVICE, DIODE: SAME AS A536	ea	4								9-17	A6CR2 thru A6CR5	
P-H A712	5961-842-9864	SEMICONDUCTOR DEVICE, DIODE: SAME AS A015	ea	1								9-17	A6CR6	
P-H A713	5961-892-8706	TRANSISTOR: SAME AS A035	ea	5								9-17	A6Q1 thru A6Q5	
P-H A714		AMPLIFIER, VA702C: SAME AS A680	ea	2								9-17	A6A1, A6A2	

**SECTION IV. REPAIR PARTS FOR DIRECT SUPPORT, GENERAL SUPPORT, AND DEPOT MAINTENANCE  
(CONTINUED)**

)

(1) SMR CODE  INDEX NO.	(2)  FEDERAL STOCK NUMBER	(3) DESCRIPTION  USABLE ON CODE  REF. NUMBER & MFR CODE	(4) UNIT OF MEAS	(5) QTY INC IN UNIT	(6) 30 DAY DS MAINT ALLOWANCE			(7) 30 DAY GS MAINT ALLOWANCE			(8) 1-YR ALW PER EQUIP CNTGY	(9) DEPOT MAINT ALW PER 100 EQUIP	(a) FIG. NO.	(10) ILLUS- TRATION  (b) ITEM NO./ REF DES
					(a)	(b)	(c)	(a)	(b)	(c)				
					1-20	21-50	51-100	1-20	21-50	51-100				
P-H A715	5935-852-2298	TEST JACK: SAME AS A472	ea	3								9-17	A6TP1 A6TP2, A6TP3	
P-H A716	5910-779-8404	CAPACITOR, FIXED, CERAMIC: CS13BE107K; 81349	ea	2				*	2	2		6	9-17 A6C12, A6C14	
P-0 A717	6625-922-2673	CIRCUIT CARD ASSEMBLY: C4695; 03860	ea	1				*	*	2	45	3	9-43 A19	
P-H A719		CONNECTOR: SAME AS A221	ea	1										
X2-H A720		BRACKET: B5054; 03860	ea	2										
X2-H A721	5305-054-6652	SCREW, PAN HEAD: SAME AS A232	ea	2										
X2-H A722	5305-054-6654	SCREW, PAN HEAD: M851957-30; 96906	ea	2										
X2-H A723	5310-722-5998	WASHER, FLAT: SAME AS A045	ea	2										
X2-H A724	5310-209-3990	WASHER, LOCK INTERNAL TOOTH: SAME AS A043	ea	4										
X2-H A725		NUT, HEXAGON: SAME AS A085	ea	4										
A-H-R A726		TRANSMISSION ASSEMBLY: C4709; 03860	ea	1										
X2-H A728	5305-054-6652	SCREW, PAN HEAD: SAME AS A232	ea	2										
X2-H A730	5310-550-3715	WASHER, LOCK: SAME AS A097C	ea	4										
X2-H A731		NUT, HEXAGON: SAME AS A085	ea	4										
X2-H A732		TRANSFORMER CHASSIS: C4675; 03860	ea	1										
P-H A733	5950-764-8644	TRANSFOMER, AUDIO-RADIO- FREQUENCY: LR-041; 89665	ea	2					*	2		13	6 A19T2, A19T3	
X2-H A735		NUT, HEXAGON: SAME AS A085	ea	8										
X2-H A736	5319-209-3990	WASHER, LOCK INTERNAL TOOTH: SAME AS A043	ea	8										
P-H A738	6625-771-0855	CIRCUIT CARD, ASSEMBLY: B4715; 03860	ea	1				2	2	2	45	3	9-38 A17	
X2-H A739	5305-054-5647	SCREW, PAN HEAD: SAME AS A290	ea	4										
X2-H A740		STAND-OFF: SAME AS A289	ea	4										
X2-H A741	5310-595-6211	WASHER, FLAT: SAME AS A097B	ea	4										
X2-H A742	5310-550-3715	WASHER, LOCK: SAME AS A097C	ea	4										
H A743	5305-054-5647	SCREW, PAN HEAD: SAME AS A290	ea	4										
X2-H A744		CIRCUIT CARD: B4795; 03860	ea	1										
P-H A745	5940-271-4030	TERMINAL: SAME AS A261	ea	21									A17E1 thru A17E21	
P-H A17R2	5905-069-3913	RESISTOR, FIXED, FILM: RN60D2740F; 81349	ea	2					*	2	2	6	9-38 A17R1,	
P-H A17R4	5905-069-3911	RESISTOR, FIXED, FILM RN60D1780F; 81349	ea	2					*	2	2	6	9-38 A17R3,	
P-H A17R6		RESISTOR, FIXED, FILM: RN60D11R0F; 81349	ea	2					*	2	2	6	9-38 A17R5,	

**SECTION IV. REPAIR PARTS FOR DIRECT SUPPORT, GENERAL SUPPORT, AND DEPOT MAINTENANCE  
(CONTINUED)**

(1) SMR CODE	(2) FEDERAL STOCK NUMBER	(3) DESCRIPTION  USABLE ON CODE	(4) UNIT OF MEAS	(5) QTY INC IN UNIT	(6) 30 DAY DS MAINT ALLOWANCE			(7) 30 DAY GS MAINT ALLOWANCE			(8) 1-YR ALW PER EQUIP CNTGY	(9) DEPOT MAINT ALW PER 100 EQUIP	(a) FIG. NO.	(b) ITEM NO./ REF DES	(10) ILLUS- TRATION
					(a)	(b)	(c)	(a)	(b)	(c)					
					1-20	21-50	51-100	1-20	21-50	51-100					
P-H A749	5905-958-1596	RESISTOR, FIXED, FILM: RN60D60R4F; 81349	ea	1				*	*	2		3	9-38	AT17R8	
P-H A750	5905-051-8008	RESISTOR, FIXED, FILM: RN60D7681F; 81349	ea	1				*	*	2		3	9-38	AT17R9	
P-H A751	5905-078-7777	RESISTOR, FIXED, FILM: RN60D2741F; 81349	ea	1				*	*	2		3	9-38	AT17R10	
P-H A752	5905-058-1156	RESISTOR, FIXED, FILM: RN60D2260F; 81349	ea	1				*	*	2		3	9-38	A17R11	
P-H A753	5905-988-2314	RESISTOR, FIXED, FILM: RN60D2000F; 81349	ea	1				*	*	2		3	9-38	A17R7	
P-H A754		RESISTOR, FIXED, FILM: RN60D1020F; 81349	ea	1				*	*	2		3	9-38	A17R12	
P-H A755	5905-082-1462	RESISTOR, FIXED, FILM: RN65C1820F; 81349	ea	1				*	*	2		6	9-38	A17R13	
P-H A756	5905-988-2174	RESISTOR, FIXED, FILM: RN65D37R4F; 81349	ea	2				*	2	2		6	9-38	A17R14, A17R18	
P-H A757		RESISTOR, FIXED, FILM: RN65C1150F; 81349	ea	1				*	2	2		3	9-38	A17R15	
P-H A758	5905-688-4337	RESISTOR, FIXED, FILM: RN65C1240F; 81349	ea	1				*	*	2		3	9-38	A17R16	
P-H A759		RESISTOR, FIXED, FILM: RN65C53R6F; 81349	ea	1				*	*	2		3	9-38	A17R17	
P-H A760		RESISTOR, FIXED, FILM: RN65C78R7F; 81349	ea	1				*	*	2		3	9-38	A17TR19	
P-H AT61		RESISTOR, FIXED, FILM: RN65C75R0F; 81349	ea	1				.*	*	2		3	9-38	A17R20	
P-H A762		CAPACITOR, FIXED MYLAR: SAME AS A278	ea	1								9-38		A17C1	
X2-H A762A		BRACKET: B4812; 03860	ea	1											
X2-H A762B	5305-054-6650	SCREW, PAN HEAD: SAME AS A171	ea	3											
X2-H A762	5310-209-3990	WASHER, LOCK INTERNAL TOOTH: SAME AS A043	ea	3											
P-H-R A763	6625-771-0848	CIRCUIT CARD ASSEMBLY: B4714; 03860	ea	1				2	3	4	46	3	9-40	A18	
M-H A764		SPACER: A4752; 03860	ea	4											
X2-H A766	5305-054-5647	SCREW, PAN HEAD: SAME AS A290	ea	8											
X2-H A767	5310-550-3715	WASHER, LOCK: SAME AS A097C	ea	8											
X2-H A768	5310-595-6211	WASHER, FLAT: SAME AS A097B	ea	4											
X2-H A769		CIRCUIT CARD: C4794; 03860	ea	1											
P-H A770	5940-271-4030	TERMINAL: SAME AS A261	ea	27										A18E1 thru A18E27	
P-H A18R2		RESISTOR, FIXED, FILM: RN60D3090F; 81349	ea	2				*	2	2		6	9-40	A18R1,	
P-H A18R4	5905-723-9749	RESISTOR, FIXED, FILM: RN60D1820F; 81349	ea	2				*	2	2		6	9-40	A18R3,	
P-H A18R6		RESISTOR, FIXED, FILM: RN60D22R1F; 81349	ea	2				*	2	2		6	9-40	A18R5,	
P-H A18R8		RESISTOR, FIXED, FILM: RN60D15R8F; 81349	ea	2				*	2	2		6	9-40	A18R7,	
P-H A774		RESISTOR, FIXED, FILM: RN60D23R2F; 81349	ea	1				*	*	2		3	9-40	A18R10	
P-H A775															

**SECTION IV. REPAIR PARTS FOR DIRECT SUPPORT, GENERAL SUPPORT, AND DEPOT MAINTENANCE  
(CONTINUED)**

(1) SMR CODE	(2) FEDERAL STOCK NUMBER	(3) DESCRIPTION  USABLE ON CODE	(4) UNIT OF MEAS	(5) QTY INC IN UNIT	(6) 30 DAY DS MAINT			(7) 30 DAY GS MAINT			(8) 1-YR ALW PER EQUIP CNTGY	(9) DEPOT MAINT ALW PER 100 EQUIP	(a) FIG. NO.	(10) ILLUS- TRATION  (b) ITEM NO./ REF DES
					ALLOWANCE	ALLOWANCE	ALLOWANCE	ALLOWANCE	ALLOWANCE	ALLOWANCE				
					(a) 1-20	(b) 21-50	(c) 51-100	(a) 1-20	(b) 21-50	(c) 51-100				
P-H A776	5905-763-8305	RESISTOR, FIXED, FILM: RN60D6340F; 81349	ea	1				*	*	2		3	9-40	A18R11
P-H A777	5905-012-5347	RESISTOR, FIXED, FILM: R60D3920F; 81349	ea	1				*	*	2		3	9-40	A18R12
P-H A778		RESISTOR, FIXED, FILM: RN60D1400F; 81349	ea	2				*	2	2		6	9-40	A18R13 A18R14
P-H A780	5905-763-6651	RESISTOR, FIXED, FILM: RN60D63R4F; 81349	ea	1				*	*	2		3	9-40	A18R15
P-H A781	5905-925-1511	RESISTOR, FIXED, FILM: RN65C1180F; 81349	ea	1				*	*	2		3	9-40	A18R17
P-H A782	5905-925-1517	RESISTOR, FIXED, FILM: RN65C73R2F; 81349	ea	1				*	*	2		3	9-40	A18R18
P-H A783		RESISTOR, FIXED, FILM: RN65C46R4F; 81349	ea	1				*	*	2		3	9-40	A18R19
P-H A784		RESISTOR, FIXED, FILM: RN65C29R4F; 81349	ea	1				*	*	2		3	9-40	A18R20
P-H A785		RESISTOR, FIXED, FILM: RN65C20R0F; 81349	ea	2				*	2	2		6	9-40	A18R21 A18R28
P-H A786		RESISTOR, FIXED, FILM: RR65C16R9F; 81349	ea	1				*	*	2		3	9-40	A18R22
P-H A787	5905-752-6715	RESISTOR, FIXED, FILM: SAME AS A652	ea	1									9-40	A18R23
P-H A788		RESISTOR, FIXED, FILM: RN65C1270F; 81319	ea	1				*	*	2		3	9-40	A18R24
P-H A789		RESISTOR, FIXED, FILM: SAME AS A760	ea	2									9-40	A18R25
P-H A790		RESISTOR, FIXED FILM: RH65C49R9F; 81349	ea	1				*	*	2		3	9-40	A18R32 A18R26
P-H A791		RESISTOR, FIXED, FILM: RN65C31R6F; 81349	ea	1				*	*	2		3	9-40	A8R27
P-H A793		RESISTOR, FIXED, FILM: RN65C60R4F; 81349	ea	2				*	2	2		6	9-40	A18R29 A18R30
P-H A794		RESISTOR, FIXED, FILM: RN65C64R9F; 81349	ea	1				*	*	2		3	9-40	A18R31
P-H A795	5905-082-1462	RESISTOR, FIXED, FILM: SAME AS A755	ea	1									9-40	A18R16
P-H A796		RESISTOR, FIXED, FILM: RN65C93R1F; 81349	ea	1				*	*	2		3	9-40	A18R33
P-H A797		RESISTOR, FIXED, FILM: RN65C95R3F; 81349	ea	1				*	*	2		3	9-40	A18R34
P-H A798	5905-835-5888	RESISTOR, FIXED, FILM: RN65C1050F; 81349	ea	1				*	*	2		3	9-40	A18R35
P-H A799		CAPACITOR, FIXED, MYLAR: SAME AS A278	ea	1									9-40	A18C1
P-O-R A800	6625-771-0229	CIRCUIT CARD ASSEMBLY: C4700; 03860	ea	1				2	3	6	50	3	9-23	A8
P-H A802 A8R45	5905-723-5251	RESISTOR, FIXED, COMPOSITION: SAME AS A267	ea	4									9-23	A8R1, A8R22 A8R24,
P-H A803	5905-682-4099	RESISTOR, FIXED, COMPOSITION: SAME AS A604	ea	2									9-23	A8R2
P-H A804	5905-686-3368	RESISTOR, FIXED, COMPOSITION: SAME AS A110	ea	5									9-23	A8R3 thru A8R6 A8R40
P-H A805	5905-807-4954	RESISTOR, FIXED, COMPOSITION: SAME AS A453	ea	2									9-23	A8R7, A8R28
P-H A806	5905-800-8063	RESISTOR, FIXED, COMPOSITION: SAME AS A401	ea	1									9-23	A8R8
P-H A807	5905-801-6998	RESISTOR, FIXED, COMPOSITION: SAME AS A366	ea	1									9-23	A8R9

**SECTION IV. REPAIR PARTS FOR DIRECT SUPPORT, GENERAL SUPPORT, AND DEPOT MAINTENANCE  
(CONTINUED)**

(1) SMR CODE	(2) FEDERAL STOCK NUMBER	(3) DESCRIPTION  USABLE ON CODE	(4) UNIT OF MEAS	(5) QTY INC IN UNIT	(6) 30 DAY DS MAINT ALLOWANCE			(7) 30 DAY GS MAINT ALLOWANCE			(8) 1-YR ALW PER EQUIP CNTGY	(9) DEPOT MAINT ALW PER 100 EQUIP	(10) ILLUS- TRATION	
					(a)	(b)	(c)	(a)	(b)	(c)			(a)	(b)
					1-20	21-50	51-100	1-20	21-50	51-100			FIG. NO.	ITEM NO./ REF DES
P-H A808 A8R27	5905-681-6462	RESISTOR, FIXED, COMPOSITION: SAME AS A031	ea	5								9-23	A8R10, A8R19 ASR26,  A8R67	
P-H A809 A8R62	5905-892-6941	RESISTOR, FIXED, COMPOSITION: SAME AS A115	ea	4								9-23	A8R11, A8R14 A8R38,	
P-H A810	5905-686-3128	RESISTOR, FIXED, COMPOSITION: SAME AS A504	ea	1								9-23	A8R12	
P-H A811	5905-817-7971	RESISTOR, FIXED, COMPOSITION: SAME AS A649	ea	3								9-23	A8R13, AR815 A8R16	
P-H A812	5905-726-4413	RESISTOR, FIXED, COMPOSITION: SAME AS A027	ea	2								9-23	A8R17, A8R57	
P-H A813	5905-682-4108	RESISTOR, FIXED, COMPOSITION: SAME AS A510	ea	2								9-23	AR18, A8R29	
P-H A8R21 A814	5905-682-0202	RESISTOR, FIXED, FILM:  RN65C3322F; 81349	ea	2				*	2	2	6	9-23	A8R20,	
P-H A815	5905-833-2271	RESISTOR, FIXED, FILM: SAME AS A367	ea	1								9-23	A8R23	
P-H A816	5905-752-3976	RESISTOR, FIXED, FILM: RN65C5112F; 81349	ea	1				*	*	2	3	9-23	A8R25	
P-H A817	5905-686-3798	RESISTOR, FIXED, COMPOSITION: SAME AS A612	ea	1								9-23	A8R30	
P-H A818	5905-691-0195	RESISTOR, FIXED, COMPOSITION: SAME AS A365	ea	1								9-23	A8R31	
P-H A819	5905-683-7721	RESISTOR, FIXED, COMPOSITION: SAME AS A112	ea	2								9-23	A8R32, A8R33	
P-H A820	5905-686-9991	RESISTOR, FIXED, COMPOSITION: SAME AS A488	ea	1								9-23	A8R34	
P-H A821	5905-683-2241	RESISTOR, FIXED, COMPOSITION: SAME AS A037	ea	3								9-23	A8R35, A8R41 A8R60	
P-H A822	5905-682-4100	RESISTOR, FIXED, COMPOSITION: RC07GF622J; 81349	ea	1				*	*	2	3	9-23	A8R36	
P-H A823	5905-683-2238	RESISTOR, FIXED, COMPOSITION: SAME AS A298	ea	1								9-23	A8R39	
P-H A824	5905-752-3973	RESISTOR, FIXED, FILM: SAME AS A631A	ea	1								9-23	A8R42	
P-H A825	5905-823-3580	RESISTOR, FIXED, FILM: RN65C1331F; 81349	ea	1				*	*	2	3	9-23	A8R43	
P-H A826	5905-804-6823	RESISTOR, FIXED, FILM: RH65C3321F; 81319	ea	1				*	*	2	3	9-23	A8R44	
P-H A827	5905-836-2662	RESISTOR, FIXED, FILM: RN65C2051F; 81349	ea	1				*	*	2	3	9-23	A8R46	
P-H A828		RESISTOR, FIXED, FILM: RN65C3921F; 81349	ea	1				*	*	2	3	9-23	A8R47	
P-S A829		RESISTOR, FIXED, FILM: SAME AS A369	ea	1								9-23	A8R48	
P-H A830	5905-683-7723	RESISTOR, FIXED, COMPOSITION: SAME AS A036	ea	1								9-23	A8R49	
P-H A831	5905-752-3602	RESISTOR, FIXED, FILM SAME AS A377	ea	1								9-23	A8R50	
P-H A832	5905-825-0955	RESISTOR, FIXED, FILM RN65C1501F; 81349	ea	1				*	*	2	3	9-23	A8R51	
P-H A833	5905-717-5884	RESISTOR, VARIABLE: SAME AS A378	ea	1								9-23	A8R52	
P-H A834	5905-682-4097	RESISTOR, FIXED, COMPOSITION SAME AS A272	ea	1								9-23	A8R53	
P-H A835	5905-823-3508	RESISTOR, FIXED, FILM: RN65C5622F; 81349	ea	1				*	*	2	3	9-23	A8R54	
P-H A836	5905-689-6799	RESISTOR, VARIABLE, TRIM POT: SAME AS A299	ea	1								9-23	A8R55	



**SECTION IV. REPAIR PARTS FOR DIRECT SUPPORT, GENERAL SUPPORT, AND DEPOT MAINTENANCE  
(CONTINUED)**

(1) SMR CODE	(2) FEDERAL STOCK NUMBER	(3) DESCRIPTION  USABLE ON CODE	(4) UNIT OF MEAS	(5) QTY INC IN UNIT	(6) 30 DAY DS MAINT ALLOWANCE			(7) 30 DAY GS MAINT ALLOWANCE			(8) 1-YR ALW PER EQUIP CNTGY	(9) DEPOT MAINT ALW PER 100 EQUIP	(a) FIG. NO.	(10) ILLUS- TRATION  (b) ITEM NO./ REF DES
					(a)	(b)	(c)	(a)	(b)	(c)				
					1-20	21-50	51-100	1-20	21-50	51-100				
P-H A8R63	5905-806-4600	RESISTOR, FIXED, FILM:	ea	2								9-23	A8R56,	
A837		SAME AS A410												
P-H A838	5905-689-9608	RESISTOR, VARIABLE: SAME AS A601	ea	3								9-23	A8R58, A8R59 A8R68	
P-H A839	5905-683-2243	RESISTOR, FIXED, COMPOSITION: SAME AS A459	ea	1								9-23	A8R61	
P-H A840		RESISTOR, FIXED, FILM: RN65C7680F; 81349	ea	1				*	*	2	3	9-23	A8R64	
P-H A841	5905-714-3413	RESISTOR, VARIABLE: RT12C2P101; 81349	ea	1				*	*	2		3	9-23	ABR65
P-H A842	5905-752-3971	RESISTOR, FIXED, FILM: RN65C2490F; 81349	ea	1				*	*	2		3	9-23	A8R66
P-H A8C5		CAPACITOR, FIXED,	ea	2				2	2	2		9	9-23	A8C1,
A843		ELECTROLYTIC: CE11C101E; 81349												
P-H A844	5910-926-0048	CAPACITOR, FIXED, ELECTROLYTIC: SAME AS A671	ea	1									9-23	A8C2
P-H A845	5910-904-8488	CAPACITOR, FIXED,	ea	3									9-23	A8C3, A8C15, AC18
P-H A846	5910-771-8970	ELECTROLYTIC: SAME AS A012 CAPACITOR, FIXED, TANTALUM: SAME AS A666	ea	5									9-23	A8C4, A8C7 A8C8,
A8C16A														
P-H A847	5910-835-2735	CAPACITOR, FIXED, MICA: SAME AS A102	ea	1									9-23	A8C16B A8C6
P-B A848	5910-835-2710	CAPACITOR, FIXED, TANTALUM: CTM-103VAJ; 81349	ea	1				*	*	2		3	9-23	A89
P-H A849		CAPACITOR, FIXED, CERAMIC: SAME AS A521	ea	2									9-23	A8C10, A8C11
P-H A850		CAPACITOR, FIXED, MICA: CM0SF510J03; 81349	ea	1				*	*	2		3	9-23	A8C12
P-H A851	5910-051-4612	CAPACITOR, FIXED, MICA: SAME AS A101	ea	2									9-23	A8C13, A8C14
P-H A852		CAPACITOR, FIXED, ELECTROLYTIC: CE11C1S0D; 81349	ea	1				*	*	2		3	9-23	A8C17
P-H A853	5961-842-9864	SEMICONDUCTOR DEVICE, DIODE: SAME AS A015	ea	18									9-23	A8CR1 thru A8CR14, A8CR16 A8CR18, A8CR19 A8CR20
P-H A854	5961-752-6121	SEMICONDUCTOR DEVICE, DIODE ZENER: SAME AS A390B	ea	2									9-23	A8CR15, A8CR17
P-H A856	5961-892-8706	TRANSISTOR: SAME AS A035 (ITEM NO. A8Q1, A8Q2, A8Q4, A8Q5, A8Q6, A8Q8 thru A8Q11, A8Q13 thru A8Q16)	ea	13									9-23	(See Des. Column)
P-H A857	5961-072-0128	TRANSISTOR: SAME AS A287	ea	3									9-23	A843, A8Q7 A8Q12
P-H A858	5962-066-0174	INTERGRATED, CIRCUIT: SAME AS A332	ea	1									9-23	A8M1
P-H A859		AMPLIFIER, VA702C: SAME AS A680	ea	1									9-23	A8A1
P-H A860	5935-852-2298	TEST JACK: SAME AS A472	ea	3									9-23	A8TP1, A8TP2 A8TP3
P-O-R A861	6625-771-0849	CIRCUIT CARD, ASSEMBLY: C4801; 03860	es	1				2	3	6	50	3	9-21	A3
P-H A863	5905-683-2238	RESISTOR, FIXED, COMPOSITION: SAME AS A298	ea	2									9-21	A3R1, A3R44
P-H A864	5905-723-5251	RESISTOR, FIXED, COMPOSITION: SAME AS A267	ea	6									9-21	A3R2, A3R12
	A3R27, A3R38													A3R40, A3R48 A3R3, A3R36
P-H A865	5905-681-9969	RESISTOR, FIXED, COMPOSITION: SAME AS A030	ea	2									9-21	A3R4, A3R20, A3R21,
P-H A866	5905-681-6462	RESISTOR, FIXED, COMPOSITION: SAME AS A031	ea	4									9-21	

**SECTION IV. REPAIR PARTS FOR DIRECT SUPPORT, GENERAL SUPPORT, AND DEPOT MAINTENANCE  
(CONTINUED)**

(1) SMR CODE	(2) FEDERAL STOCK NUMBER	(3) DESCRIPTION  USABLE ON CODE	(4) UNIT OF MEAS	(5) QTY INC IN UNIT	(6) 30 DAY DS MAINT ALLOWANCE			(7) 30 DAY GS MAINT ALLOWANCE			(8) 1-YR ALW PER EQUIP CNTGY	(9) DEPOT MAINT ALW PER 100 EQUIP	(a) FIG. NO.	(b) ITEM NO./ REF DES	(10) ILLUS- TRATION
					(a)	(b)	(c)	(a)	(b)	(c)					
					1-20	21-50	51-100	1-20	21-50	51-100					
A867	5905-686-3798	RESISTOR, FIXED, COMPOSITION: SAME AS A612	ea	1								9-21	A3R5		
A868	5905-686-9994	RESISTOR, FIXED, COMPOSITION: SAME AS A488	ea	2								9-21	A3R6, A3R17		
A869	5905-686-9998	RESISTOR, FIXED, COMPOSITION: SAME AS A444	ea	3								9-21	A3R7, A3R18, A3R25		
A870	5905-726-4413	RESISTOR, FIXED, COMPOSITION: SAME AS A027	ea	3								9-21	A3R8, A3R9, A3R10		
A871	5905-892-6941	RESISTOR, FIXED, COMPOSITION: SAME AS A115	ea	3								9-21	A3R11, A3R29 A3R37		
A872	5905-683-2246	RESISTOR, FIXED, COMPOSITION: SAME AS A495	ea	4								9-21	A3R13 thru A3R16		
A873	5905-688-3738	RESISTOR, FIXED, COMPOSITION: SAME AS A271	ea	4								9-21	A3R19, A3R22		
A874	A3R28,A3R49 5905-835-1631	RESISTOR, FIXED, COMPOSITION: SAME AS A633C	ea	1								9-21	A3R23		
A875	5905-683-2241	RESISTOR, FIXED, COMPOSITION: SAME AS A037	ea	2								9-21	A3R24, A3R43		
A876	5905-682-4101	RESISTOR, FIXED, COMPOSITION: RC07GF752J; 81349	ea	1				*	*	2		3	9-21	A3R26	
A877	5905-687-0000	RESISTOR, FIXED, COMPOSITION: SAME AS A696	ea	1								9-21	A3R30		
A878	5905-800-3478	RESISTOR, FIXED, COMPOSITION: RC07GF753; 81349	ea	1				*	*	2		3	9-21	A3R31	
A879	5905-721-0597	RESISTOR, FIXED, COMPOSITION: RC07GF243J; 81349	ea	1				*	*	2		3	9-21	A3R32	
A880	5905-892-6941	RESISTOR, FIXED, COMPOSITION: SAME AS A115	ea	1								9-21	A3R33		
A881	5905-691-0195	RESISTOR, FIXED, COMPOSITION: SAME AS A365	ea	1								9-21	A3R34		
A882	5905-805-9714	RESISTOR, FIXED, COMPOSITION: SAME AS A299A	ea	1								9-21	A3R35		
A883	5905-681-9970	RESISTOR, FIXED, COMPOSITION: SAME AS A494	ea	1								9-21	A3R39		
A884	5905-686-3370	RESISTOR, FIXED, COMPOSITION: SAME AS A025	ea	2								9-21	A3R41, A3R45		
A885	5905-681-8853	RESISTOR, FIXED, COMPOSITION: RC07GF683J; 81349	ea	1				*	*	2		3	9-21	A3R46	
A886	5905-682-4097	RESISTOR, FIXED, COMPOSITION: SAME AS A272	ea	1								9-21	A3R47		
A887	5910-904-8488	CAPACITOR, FIXED, ELECTROLYTIC: SAME AS A012	ea	3								9-21	A3C1, A3C2, A3C3		
A888	5910-088-1146	CAPACITOR, FIXED, MICA: CM05F331J03; 81349	ea	3				2	2	2		9	9-21	A3C4, A3C7, A3C11	
A889		CAPACITOR, FIXED MICA: CTM333VAK; 81349	Ca	2				*	2	2		6	9-21	A3C5,	
A890		CAPACITOR, FIXED, MICA: CTM332VBK; 81349	ea	2				*	2	2		6	9-21	A3C6,	
A891		CAPACITOR, FIXED, MICA: CTM332VBK; 81349	ea	2				*	2	2		6	9-21	A3C5,	
A892	5910-054-6919	CAPACITOR, FIXED, ELECTROLYTIC: CE11C100E; 81349	ea	2				*	2	2		6	9-21	A3C13, A3C15	
A893	5910-835-2711	CAPACITOR, MYLAR: SAME AS A382	ea	1								9-21	A3C14		
A894		CAPACITOR, FIXED, ELECTROLYTIC: CELLC050F; 81349	ea	1				*	*	2		3	9-21	A3C16	
A895	5910-959-3258	CAPACITOR, FIXED, ELECTROLYTIC: CE11C201D; 81349	ea	1				*	*	2		3	9-21	A3C17	

**SECTION IV. REPAIR PARTS FOR DIRECT SUPPORT, GENERAL SUPPORT, AND DEPOT MAINTENANCE  
(CONTINUED)**

(1) SMR CODE	(2) FEDERAL STOCK NUMBER	(3) DESCRIPTION  USABLE ON CODE	(4) UNIT OF MEAS	(5) QTY INC IN UNIT	(6) 30 DAY DS MAINT ALLOWANCE			(7) 30 DAY GS MAINT ALLOWANCE			(8) 1-YR ALW PER EQUIP CNTGY	(9) DEPOT MAINT ALW PER 100 EQUIP	(a) FIG. NO.	(b) ITEM NO./ REF DES	(10) ILLUS- TRATION
					(a)	(b)	(c)	(a)	(b)	(c)					
					1-20	21-50	51-100	1-20	21-50	51-100					
P-H A896	5910-067-9095	CAPACITOR, FIXED, ELECTROLYTIC: CE11C010G; 81349	ea	1				*	*	2		3	9-21	A3C18	
P-H A897	5910-943-9340	CAPACITOR, FIXED ELECTROLYTIC: SAME AS A706	a	1									9-21	A3C19	
P-H A898	5961-842-9864	SEMICONDUCTOR DEVICE, DIODE: SAME AS A015	ea	9									9-21	A3CR1 thru A3CR9	
P-H A899	5961-892-8706	TRANSISTOR: SAME AS A035	ea	11									9-21	A3Q1 thru A3Q4,A3Q6 A3Q7,	
A3Q11														thru A3Q15	
P-H A900	5961-072-0128	TRANSISTOR: SAME: AS A287	ea	4									9-21	05,08,09,010	
P-H A901	5935-852-2298	TEST JACK: SAME AS A472	ea	2									9-21	A3TP1,A3TP2	
P-H A901A		CAPACITOR, FIXED, ELECTROLYTIC: SAME AS A843	ea	1									9-21	A3C20	
M-D A902		COVER BOTTOM ASSY: D4747; 03860	ea	1											
11-D A903		COVER BOTTOM: D4677-1; 03860	ea	1											
X1-D A904		STRAP: B4755; 03860	ea	1											
X2-H A905		WEATHER STRIP: B4825; 03860	ea	1											
X2-H A906		SCREW, PAN HEAD: M851957-4; 96906	ea	24											
X2-H A907	5310-543-4652	WASHER, LOCK: SAME AS 48	ea	7											
X2-H A908	5310-938-2013	NUT, HEXAGON: SAME AS A050	ea	7											
12-H A909		SCREW, CAPTIVE: SAME AS A056	ea	8											
X2-H A910	5310-209-3990	WASHER, LOCK INTERNAL TOOTH: SAME AS A043	ea	8											
A-H A911		COVER TOP ASSY: D4754; 03860	ea	1											
X2-H A912		COVER TOP: D4708; 03860	ea	1											
X1-D- A913		STRAP: SAME AS A904	ea	1											
X2-H A914		WEATHER STRIP: SAME AS A905	ea	1											
X2-H A915		SCREW, PAN HEAD: SAME AS A906	ea	7											
X2-H A916	5310-543-652	WASHER, LOCK: SAME AS A048	ea	7											
12-H A917	5910-938-2013	NUT HEXAGON: SAME AS A050	ea	7											
X2-H A918		BRACKET, SPRING MOUNTED B4748; 03860	ea	2											
12-H A919		CONTACT, FINGER: B4684; 03860	ea	2											
X2-H A920		RETAINER: B4794; 03860	ea	2											
X2-H A921		SCREW PAN HEAD: NS51957-1; 96906	ea	8											
X2-H A922	5310-543-4652	WASHER, LOCK: SAME AS A048	ea	8											

**SECTION IV. REPAIR PARTS FOR DIRECT SUPPORT, GENERAL SUPPORT, AND DEPOT MAINTENANCE  
(CONTINUED)**

(1) SMR CODE	(2) FEDERAL STOCK NUMBER	(3) DESCRIPTION  USABLE ON CODE	(4) UNIT OF MEAS	(5) QTY INC IN UNIT	(6) 30 DAY DS MAINT ALLOWANCE			(7) 30 DAY GS MAINT ALLOWANCE			(8) 1-YR ALW PER EQUIP CNTGY	(9) DEPOT MAINT ALW PER 100 EQUIP	(a) FIG. NO.	(b) ITEM NO./ REF DES
					(a)	(b)	(c)	(a)	(b)	(c)				
					1-20	21-50	51-100	1-20	21-50	51-100				
X2-H A923	5305-054-5648	SCREW, PAN HEAD: SAME A8 A087	ea	6										
X2-H A924	5310-543-4652	WASHER LOCK: SAME AS A048	ea	6										
X2-H A925	5310-938-2013	NUT, HEXAGON: SAME AS A050	ea	6										
X2-H A926		BRACKET PC CARD: B4791; 03860	ea	2										
X2-H A927		SCREW PAN HEAD: SAME A8 A906	ea	4										
X2-H A928	5310-543-4652	WASHER LOCK: SAME AS A048	ea	4										
X2-H A929	5310-938-2013	NUT, HEXAGON: SAME AS A050	ea	4										
X2-H A930		SCREW, CAPTIVE: SAME AS A056	ea	8										
X2-H A931	5310-550-3715	WASHER LOCK: SAME AS A097C	ea	8										
X2-HB A932		PAD: B4632-2; 03860	ea	2										
P-O A933		EXTRACTOR, CIRCUIT BOARD: 1731; 78769	ea	1			*	*	2	8	3			
X1-H A934		HOLDER DETAIL: B4851; 03860	ea	1										
X2-H A935		CLAMP DETAIL: B4852; 03860	ea	1										
X2-H A936	5305-054-5648	SCREW PAN HEAD: SAME AS AA87	ea	4										
X2-H A937	5310-550-3715	WASHER, LOCK: SAME AS A097C	ea	4										
X2-H A938		NUT HEXAGON: SAME AS A142	ea	4										
P-O A939		TOOL, COIL TUNNING: 2033-1; 71279	ea	1			*	*	2	2	3			
X2-H A940		CLIP, SPRING: 6008-67AN; 91506	ea	1										
X2-H A941		SCREW PAN HEAD: SAME AS A047	ea	1										
X2-H A942	5310-543-4652	WASHER, LOCK: SAME AS A048	ea	1										
X2-H A943	5310-938-2013	NUT HEXAGON: SAME AS A050	ea	1										

**SECTION V. INDEX-FEDERAL STOCK NUMBER CROSS REFERENCE TO INDEX NUMBER**

FEDERAL STOCK NUMBER ↔	INDEX NO. ↔	FEDERAL STOCK NUMBER ↔	INDEX NO. ↔	FEDERAL STOCK NUMBER ↔	INDEX NO. ↔
		5310-058-2949	A088	5905-279-3498	A020
		5310-209-3990	A043	5905-577-0435	A067
		5310-543-2739	A163	5905-577-3608	A058
		5310-543-4652	A048	5905-581-1963	A399
		5310-550-3715	A097C	5905-581-2852	A066
		5310-595-6211	A097B	5905-681-6462	A031
5305-054-5646	A352	5310-595-6761	A469	5905-681-8818	A264
5305-054-5647	A290	5310-722-5998	A045	5905-681-8853	A885
5305-054-5648	A087	5310-938-2013	A050	5905-681-9969	A030
5305-054-5650	A167	5355-539-8942	A160	5905-681-9970	A494
5305-054-5651	A222	5355-584-4247	A159	5905-682-0202	A814
5305-054-6650	A171	5355-680-1357	A156	5905-682-0214	A631C
5305-054-6651	A044	5355-814-0470	A158	5905-682-4083	A616
5305-054-6652	A232	5355-850-9799	A157	5905-682-4095	A615
5305-054-6654	A722	5905-012-5347	A777	5905-682-4097	A272
5305-054-6655	A183	5905-051-8008	A750	5905-682-4098	A028
5305-054-6667	A205	5905-058-1156	A752	5905-682-4099	A604
5305-054-6668	A162	5905-061-4017	A685	5905-682-4100	A822
5305-054-6669	A186	5905-061-5355	A646	5905-682-4101	A876
5305-054-6670	A245	5905-069-3911	A747	5905-682-4103	A507
5305-059-7201	A052	5905-069-3913	A746	5905-682-4105	A644
5305-059-8449	A190	5905-078-7777	A751	5905-682-4108	A510
5305-579-3511	A096	5905-082-1462	A755	5905-682-4109	A457
5305-638-0653	A121	5905-171-2003	A023	5905-682-4110	A462
5305-639-4777	A149	5905-195-6761	A021	5905-683-2235	A647
5305-763-7822	A130	5905-202-0377	A203	5905-683-2236	A375
5305-843-2841	A155	5905-257-0935	A024	5905-683-2238	A298
5310-043-1754	A084	5905-279-2669	A022	5905-683-2241	A037

**SECTION V. INDEX-FEDERAL STOCK NUMBER CROSS REFERENCE TO INDEX NUMBER  
(CONTINUED)**

FEDERAL STOCK NUMBER ↔	INDEX NO. ↔	FEDERAL STOCK NUMBER ↔	INDEX NO. ↔	FEDERAL STOCK NUMBER ↔	INDEX NO. ↔
5905-683-2242	A514	5905-688-4337	A758	5905-761-5409	A411
5905-683-2243	A459	5905-689-6799	A299	5905-763-6651	A780
5905-683-2246	A495	5905-689-9608	A601	5905-763-8305	A776
5905-683-7721	A112	5905-691-0195	A365	5905-782-0909	A273
5905-683-7723	A036	5905-702-4439	A455	5905-800-0179	A497
5905-683-7724	A509	5905-702-8755	A651	5905-800-3478	A878
5905-686-3119	A659	5905-714-3413	A841	5905-800-8063	A401
5905-686-3122	A503	5905-717-5884	A378	5905-801-2377	A658
5905-686-3128	A504	5905-721-0597	A879	5905-801-6444	A409
5905-686-3129	A458	5905-721-1488	A441	5905-801-6998	A366
5905-686-3130	A448	5905-723-5251	A267	5905-801-8272	A029
5905-686-3356	A500	5905-723-9749	A772	5905-802-6730	A445
5905-686-3358	A026	5905-725-6995	A407	5905-803-2908	A450
5905-686-3368	A110	5905-726-3807	A265	5905-804-6823	A826
5905-686-3369	A516	5905-726-4413	A027	5905-805-9713	A565
5905-686-3370	A025	5905-727-8001	A408	5905-805-9714	A299A
5905-686-3379	A436	5905-752-3186	A491	5905-806-4599	A631B
5905-686-3798	A612	5905-752-3308	A440	5905-806-4600	A410
5905-686-3838	A451	5905-752-3597	A439	5905-807-2570	A373
5905-686-3903	A496	5905-752-3602	A377	5905-807-4954	A453
5905-686-9994	A488	5905-752-3955	A638	5905-810-0946	A437
5905-686-9995	A434	5905-752-3957	A655	5905-817-7971	A649
5905-686-9996	A371	5905-752-3971	A842	5905-823-3508	A835
5905-686-9997	A296	5905-752-3973	A631A	5905-823-3580	A825
5905-686-9998	A444	5905-752-3974	A269	5905-825-0955	A832
5905-687-0000	A696	5905-752-3976	A816	5905-827-4815	A650
5905-687-0002	A492	5905-752-6715	A652	5905-828-7762	A370
5905-688-3738	A271	5905-755-8389	A460	5905-833-2271	A367

**SECTION V. INDEX-FEDERAL STOCK NUMBER CROSS REFERENCE TO INDEX NUMBER  
(CONTINUED)**

← FEDERAL STOCK NUMBER →	← INDEX NO. →	← FEDERAL STOCK NUMBER →	← INDEX NO. →	← FEDERAL STOCK NUMBER →	← INDEX NO. →
5905-834-2750	A268	5910-771-8970	A666	5930-501-1749	A080
5905-835-1631	A633C	5910-779-8404	A716	5930-655-1515	A005
5905-835-5888	A798	5910-781-4511	A582	5930-655-1575	A075
5905-836-2662	A827	5910-822-5683	A032	5930-655-1581	A060
5905-892-6941	A115	5910-834-9765	A677	5935-081-2502	A046
5905-894-0825	A438	5910-835-2710	A848	5935-237-2507	A069
5905-905-3335	A073	5910-835-2711	A382	5935-502-5151	A070
5905-925-1511	A781	5910-835-2715	A395	5935-577-8761	A051
5905-925-1517	A782	5910-835-2735	A102	5935-578-2945	A189
5905-958-1596	A749	5910-835-2739	A381	5935-852-2298	A472
5905-978-7274	A657	5910-835-2958	A631E	5935-990-1441	A210
5905-988-2174	A756	5910-847-7288	A672	5935-990-6219	A467
5905-988-2314	A753	5910-892-2647	A179	5940-159-0245	A485
5910-045-5434	A578	5910-901-5875	A277	5940-271-4030	A261
5910-051-4612	A101	5910-904-8488	A012	5940-983-6047	A181
5910-054-6919	A892	5910-926-0048	A671	5940-983-6069	A194
5910-056-7976	A523	5910-943-4079	A380	5950-764-8644	A733
5910-057-0920	A100	5910-943-9298	A383	5950-994-6600	A429
5910-060-1190	A417	5910-943-9340	A706	5961-072-0128	A287
5910-060-1194	A621	5910-952-6432	A668	5961-226-8692	A209
5910-067-9095	A896	5910-954-1770	A421	5961-556-2091	A536
5910-079-9474	A176	5910-954-5500	A422	5961-688-6316	A174
5910-082-4898	A580	5910-954-5505	A530	5961-752-6121	A390B
5910-087-3468	A520	5910-957-9908	A525	5961-809-9049	A208
5910-088-1146	A888	5910-957-9909	A579	5961-813-9360	A355
5910-577-1194	A522	5910-959-3258	A895	5961-842-9864	A015
5910-709-0343	A665	5910-965-9441	A583	5961-849-4176	A360
5910-717-5853	A705	5910-989-6427	A527	5961-855-1551	A356
5910-724-5523	A577	5910-995-0614	A528	5961-866-5454	A411A

**SECTION V. INDEX-FEDERAL STOCK NUMBER CROSS REFERENCE TO INDEX NUMBER  
(CONTINUED)**

<b>FEDERAL STOCK NUMBER</b>	<b>INDEX NO.</b>	<b>REF NUMBER</b>	<b>INDEX NO.</b>	<b>REF NUMBER</b>	<b>INDEX NO.</b>
5961-892-8706	A035	A4649	A228	B4682	A592
5961-911-6015	A034	A4655	A154	B4683	A537
5962-066-0174	A332	A4752	A764	B4684	A919
6240-223-9100	A093A	A4810	A595	B4686	A473
6625-042-5434	A089	A4813-1	A289	B4687	A062
6625-717-7018	A010	A4813-2	A120	B4689	A072
6625-717-7024	A288	A4819	A145	B4694	A161
6625-717-7458	A597	A4820	A140	B4741	A466
6625-717-7461	A542	B4626-1	A589	B4748	A918
6625-717-7480	A097	B4626-2	A590	B4755	A904
6625-759-8241	A134	B4628	A007	B4791	A926
6625-759-8242	A132	B4632	A054	B4794	A920
6625-764-8509	A300	B4632-2	A932	B4795	A744
6625-771-0224	A327	B4638	A008	B4807	A293
6625-771-0229	A300	B4639	A478	B4812	A762A
6625-771-0230	A335	B4654	A135	B4825	A905
6625-771-0615	A345	B4657	A151	B4850	A136
6625-771-0641	A259	B4658	A148	B4851	A934
6625-771-0651	A412	B4660	A071	B4852	A935
6625-771-06514	A385	B4661	A079	B5037	A056
6625-771-0666	A483	B4662	A068	B5054	A720
6625-771-08148	A763	5B4663	A061	CE11C050F	A894
				CE11C080H	A013
6625-771-0849	A861	B4664	A063	CE11C101E	A843
				CE11C150D	A852
6625-771-0855	A738	B4665	A004	CE13C900G	A379
6625-771-0860	A681	B4666	A078	CE41C152F	A180
6625-771-0863	A632	B4672	A059	CE41C152G	A178
6625-880-1578	A001	B4678	A256	CK63AX103M	A521
6625-922-2673	A717	B4679	A165	CM05F120K03	A526

TS-2669/GCM



**SECTION V. INDEX-FEDERAL STOCK NUMBER CROSS REFERENCE TO INDEX NUMBER  
(CONTINUED)**

<b>REF NUMBER</b>	<b>INDEX NO</b>	<b>REF NUMBER</b>	<b>FIG NO</b>	<b>REF NUMBER</b>	<b>INDEX NO.</b>
CM05F150J03	A104	D4644	A249	PA771239	A680
CM05F330J03	A891	D4645	A188	RN60D1020F	A754
CM05F390G03	A524	D4646	A207	RN60D11R0F	A748
CM05F390J03	C624	D4647	A003	RN60D1400F	A778
CM05F470J03	A420	D4677-1	A903	RN60D15R8F	A774
CM05F510J03	A850	D4685	A204	RN60D22R1F	A773
CS13BC107K	A584	D4692	A185	RN60D23R2F	A775
CTM332VBK	A890	D4708	A912	RN65C1150F	A757
				RN65C1270F	A788
CTM333VAK	A889	D4712	A231	RN65C16R9F	A786
				RN65C20R0F	A785
C4600	A082	D4716	A217	RN65C29R4F	A784
C4631	A177	D4747	A902	RN65C2942F	A688
C4633	A038	D4754	A911	RN65C31R6F	A791
				RN65C3651F	A369
C4634	A053	E4688	A002	RN65C3921F	A828
C4635	A041	LF2W200	A107	RN65C46R4F	A783
C4637	A006	MC61BW104M	A418	RN65C49R9F	A790
C4648-001	A226	MC830P	A019	RN65C53R6F	A759
C3638-002	A227	MC846P	A339	RN65C60R4F	A793
C4652	A128	MS27035	A216	RN65C64R9F	A794
C4653	A119	MS35200-46	A009	RN65C75R0F	A761
		MS35250-73	A065		
C4673	A086	MS35338-136	A596B	RN65C7680F	A840
		MS35649-244	A142		
C4674	A083	MS35649-264	A085	RN65C78R7F	A760
		MS51957-1	A921		
C4675	A732	MS51957-3	A047	RN65C93R1F	A796
		MS51957-4	A906		
C4709	A726	MS51957-8	A211	RN65C95R3F	A797
		MS51959-13	A596	RW55V331J	A361
C4710	A095	MS51959-27	A246	SA9507	A139
		MS670Y-8-GEE,	A194A		
C4794	A769	STYLE 5A		SK185	A033
		MS670-6-GEE-4A	A182		
DV11PS118	A099			SN7441N	A018
		MS90078-24-1	A077		
D4641	A220			SN7473N	A628
		MS90538-001	A108		
D4642	A164			SN7490N	A017
		MS90538-19	A541A		
D4643	A242			X663FR1545.5	A282
		NAS671	A184		

**SECTION V. INDEX-FEDERAL STOCK NUMBER CROSS REFERENCE TO INDEX NUMBER  
(CONTINUED)**

REF NUMBER	INDEX NO	REF NUMBER	FIG NO	REF NUMBER	INDEX NO.
X663FR1555.5	A278				
X663FR2235.5	A283				
X663FR2245.5	A279				
X663FR3945.5	A280				
X663FR6835.5	A281				
109D128X9006W2	A625				
143-022-01-102	A221				
1731	A933				
19500/329AEL	AI06				
1JX130	A169				
1N4809A	A426				
2033-1	A939				
211-3-02	A064				
2207/PR10A	A351				
222-0111-202	A0g4				
222-0408-0111-273	A092				
3360-43	A535				
3370-17	A430				
3370-24	A588				
340255A	A076				
3700S-1-503K	A081				
4833-1	A170				
57-30140-1	A049				
6008-67AN	A940				
6082-15CN/.010	A176A				
6087-1CN/.010	A349				
81-0408-01-273	A093				

**SECTION VI. INDEX-FEDERAL STOCK NUMBER CROSS REFERENCE TO INDEX NUMBER**

← FIG NO →	ITEM NO. OR REFERENCE DESIGNATION	← REF NO →	← FIG NO. →	ITEM NO. OR REFERENCE DESIGNATION	← INDEX NO. →
9-4	A4	A412		A4R11	A443
	A4C1	A416		A4R12,	A444
	A4C2	A417		A4R13	
	A4C3	A416		A4R14	A445
	A4c4	A4419		A4R15	A446
	A4C5	A417		A4R16	A447
	A4C6	A416		A4R17	A444
	A4C7	A418		A4R18	A448
	A4C8,	A416		A4R19	A449
	A4C9			A4R20	A450
	A4C10	A420		A4R21	A451
	A4C11 thru	A416		A4R22	A452
	A4C14			A4R23	A453
	A4C16	A421		A4R24	A454
	A4C17,	A416		A4R25	A451
	A4C18,			A4R26	A455
	A4C19			A4R27	A456
	A4C20	A422		A4R28,	A457
	A4C21	A421		A4R29	
	A4C22	A422		A4R30	A452
	A4C23	A421		A4R31,	A458
	A4C24,	A416		A4R32	
	A4C25,			A4R33	A459
	A4C26			A4R34	A460
	A4C27,	A419		A4R35	A435
	A4C28			A4R36	A461
	A4C30	A416		A4R37	A462
	A4C31	A422		A4R38	A463
	A4C33	A416		A4R39	A464
	A4C34	A425		A4R40	A463
	A4C35	A416		A4R41	A465
	A4C36	A421		A4R44	A443
	A4C37	A416		A4R45	A445
	A4C38	A421		A4R46	A443
	A4C39	A416		A4R47	A446.
	A4C40	A425		A4R48	A442
	A4c4i	A420		A4TP1	A472
	A4C42	A419		A4XY1	A467
	A4C44	A416		A4Y1	A466
	A4CR1	A426			
	A4CR2,	A427	9-6	A2	A097
	A4CR3,			A2C1	A099
	A4CR4			A2C2	A100
	A4CR5	A428		A2C3	A101
	A4L1	A429		A2C4	A102
	A4L2,	A430		A2C5	A102
	A4L3			A2C6	A103
	A4L4	A433		A2C7	A099
	A41Q,	A431		A2C8	A104
	A4Q2			A2C9	A099
	A4Q3	A432		A2C10	A104
	A4Q4 thru	A431		A2C12	A103
	A4Q15			A2CR1	A106
	A4R1,	A434		A2CR2	A106
	A4R2			A2L1	A107
	A4R3	A435		A2L2	A107
	A4R4	A436		A2L3	A108
	A4R5	A437		A2Q1,	A109
	A4R6	A438		A2Q2	
	A4R7	A439		A2R1	A110
	A4R8	A440		A2R2	A111
	A4R9	A441		A2R3	A112
	A4R10	A442		A2R4	A113

**SECTION VI. INDEX-FEDERAL STOCK NUMBER CROSS REFERENCE TO INDEX NUMBER  
(CONTINUED)**

<b>FIG NO</b>	<b>ITEM NO. OR REFERENCE DESIGNATION</b>	<b>REF NO</b>	<b>FIG NO.</b>	<b>ITEM NO. OR REFERENCE DESIGNATION</b>	<b>INDEX NO.</b>
9-6	A2R5	A114		A16R32	A604
	A2R6	A111		A16R33	A615
	A2R7	A112		A16R34	A600
	A2R8	A115		A16R35	A605
				A16R36	A611
9-8	A16	A597		A16R37	A616
	A16C1	A620		A16R38,	A605
	A16C2	A621		A16R39	
	A16C3	A620		A16R40	A617
	A16C4	A622		A16R41	A600
	A16C5	A623		A16R42	A605
	A16C6	A624		A16R43	A617
	A16C7	A620		A16R44	A600
	A16C8	A625		A16R45	A618
	A16C9	A622		A16R46	A602
	A16C10	A631E		A16R47	A599
	A16CR1 thru	A626		A16R48,	A619
	A16CR4			A16R49	
	A16M1	A627		A16R50	A631D
	A16M2	A628		A16TP1,	A631
	A16Q1	A629		A16TP2	
	A16Q2	A630		A16TP3	
	A16Q3	A629			
	A16Q4,	A630	9-10	A14	A483
	A16Q5			A14C2	A519
	A16Q6	A629		A14C3	A524
	A16Q7 thru	A630		A14C4	A521
	A16Q11			A14C6	A521
	A16Q12	A629		A14C7	A522
	A16Q14	A629		A14C8,	A521
	A16Q15	A630		A14C9	
	A16Q16	A629		A14C10	A523
	A16R1	A631A		A14C11	A524
	A16R2	A599		A14C12	A521
	A16R3	A631B		A14C13	A525
	A16R4	A601		A14C14	A526
	A16R5	A631C		A14C15	A521
	A16R6	A631B		A14C16	A527
	A16R7,	A603		A14C17	A521
	A16R8			A14C18	A522
	A16R9	A604		A14C19	A528
	A16R10	A605		A14C20	A529
	A16R11	A606		A14C21	A521
	A16R12	A607		A14C22	A519
	A16R13	A604		A14C23	A521
	A16R14	A608		A14C24	A519
	A16R15	A609		A14C25	A521
	A16R16	A600		A14C26	A530
	A16R17	A604		A14C27	A528
	A16R18	A605		A14C28 thru	A529
	A16R19,	A610		A14C31	
	A16R20			A14C32	A520
	A16R21	A602		A14CR1	A533
	A16R22	A611		A14CR2	A536
	A16R23	A600		A14L1	A534
	A16R24	A604		A14L2,	A535
	A16R25	A610		A14L3	
	A16R26	A612		A14L4	A534
	A16R27	A613		A14L5	A541A
	A16R28	A602		A14Q1	A531
	A16R29	A608		A14Q3	A531
	A16R30	A605		A14Q5	A531
	A16R31	A614		A14Q7 thru	A531
				A14Q11	

**SECTION VI. INDEX-FEDERAL STOCK NUMBER CROSS REFERENCE TO INDEX NUMBER  
(CONTINUED)**

<b>FIG NO</b>	<b>ITEM NO. OR REFERENCE DESIGNATION</b>	<b>REF NO</b>	<b>FIG NO.</b>	<b>ITEM NO. OR REFERENCE DESIGNATION</b>	<b>INDEX NO.</b>
9-10	A14Q12	A532		A15C7	A577
	A14Q13,	A531		A15C8,	A576
	A14Q14,			A15C9	
	A14Q15			A15C10	A578
	A14Q16	A532		A15C11	A579
	A14Q17,	A531		A15C12	A576
	A14Q18			A15C13	A580
	A14R1	A487AC		A15C14	A581
	A14R3	A488		A15C15	A576
	A14R5	A489		A15C16	A582
	A14R9	A490		A15C17	A576
	A14R13	A491		A15C18	A577
	A14R14	A492		A15C19	A575
	A14R15	A493		A15C20	A576
	A14R17	A501		A15C23	A584
	A14R18	A513		A15C24	A574
	A14R19	A487AC		A15C25	A576
	A14R20	A494		A15C26	A583
	A14R21	A495		A15C27	A575
	A14R22	A496		A15CR1	A587
	A14R23	A497		A15L1	A588
	A14R24	A487AC		A15L2	A589
	A14R25	A498		A15L3	A590
	A14R26	A513		A15L4	A588
	A14R27	A499		A15Q1	A585
	A14R28	A500		A15Q3	A585
	A14R29	A490		A15Q5	A585
	A14R30	A501		A15Q7 thru	A585
	A14R31	A502		A15Q11	
	A14R32	A503		A15Q12	A586
	A14R33	A496		A15Q13,	A585
	A14R34	A504		A15Q14,	
	A14R35	A506		A15Q15	
	A14R36	A507		A15Q16	A586
	A14R37	A508		A15Q17,	A585
	A14R38	A509		A15Q18	
	A14R39	A489		A15R1	A547
	AL4R40	A510		A15R3	A547A
	A14R41	A505		A15R5	A547B
	A14R42	A508		A15R9	A547C
	A14R43	A511		A15R13	A548
	A14R44	A492		A15R14	A549
	A14R45	A508		A15R15	A550
	A14R46	A499		A15R17	A558
	A14R47	A500		A15R18	A567
	A14R48	A502		A15R19	A547
	A14R49	A503		A15R20	A551
	A14R50	A514		A15R21	A552
	A14R51	A515		A15R22	A553
	A14R52	A516		A15R23	A554
	A14R53	A517		A15R24	A547
	A14R54	A514		A15R25	A555
	A14R55	A510		A15R26	A567
	A14R56	A492		A15R27	A556
	A14R57	A518		A15R28	A557
	A14R58	A495		A15R29	A547C
	A14R59	A512		A15R30	A558
				A15R31	A559
	A15	A542		A15R32	A560
	A15C2	A574		A15R35	A561
	A15C3,	A576		A15R36	A562
	A15C4			A15R37	A563
	A15C6	A576		A15R38	A564

**SECTION VI. INDEX-FEDERAL STOCK NUMBER CROSS REFERENCE TO INDEX NUMBER  
(CONTINUED)**

← FIG NO →	ITEM NO. OR REFERENCE DESIGNATION	← REF NO →	← FIG NO. →	ITEM NO. OR REFERENCE DESIGNATION	← INDEX NO. →
9-12	A15R39	A547B		A7Q13,	A287
	A15R40	A565		A7Q14,	
	A15R42	A563		A7Q15	A286
	A15R43	A566		A7Q16,	
	A15R44	A549		A7Q17,	
	A15R45	A563		A7Q18	
	A15R46	A556		A7Q19,	A287
	A15R47	A557		A7Q20,	
	A15R48	A559		A7Q21	
	A15R49	A560		A7Q22,	A286
	A15R50	A565		A7Q23,	
	A15R51	A569		A7Q24	
	A15R52	A570		A7Q25,	A287
	A15R53	A571		A7Q26,	
	A15R54	A568		A7Q27	
	A15R55	A572		A7R1	A264
	A15R56	A549		A7R2	A265
	A15R57	A573		A7R3	A264
	A15R58	A552		A7R4	A265
	A15R59	A554		A7R5	A264
A15R60	A591		A7R6	A265	
9-14	A7	A259		A7R7,	A266
	A7C1,	A277		A7R8,	
	A7C2,			A7R9	
	A7C3			A7R10,	A267
	A7C4	A278		A7R11,	
	A7C5	A280		A7R12	
	A7C6	A282		A7R13,	A268
	A7C7	A279		A7R14,	
	A7C8	A281		A7R15	
	A7C9	A283		A7R16,	A269
	A7C10	A278		A7R17,	
	A7C11	A280		A7R18	
	A7C12	A282		A7R19,	A270
	A7C13	A279		A7R20,	
	A7C14	A281		A7R21	
	A7C15	A283		A7R22,	A271
	A7C16	A278		A7R23,	
	A7C17	A280		A7R24	
	A7C18	A282		A7R25,	A272
	A7C19	A279		A7R26,	
	A7C20	A281		A7R27	
	A7C21	A283		A7R28,	A268
	A7C22	A278		A7R29,	
	A7C23	A280		A7R30	
	A7C24	A282		A7R31,	A269
	A7C25	A279		A7R32,	
	A7C26	A281		A7R33	
	A7C27	A283		A7R34,	A270
	A7C28,	A285		A7R35,	
	A7C29			A7R36	
	A7C30 thru	A284		A7R37,	A271
	A7C35			A7R38,	
	A7E1 thru	A261		A7R39	
	A7E5			A7R40,	A272
	A7Q1 thru	A286		A7R41,	
	A7Q6			A7R42	
	A7Q7,	A287		A7R43,	A268
	A7Q8,			A7R44,	
A7Q9			A7R45		
A7Q10,	A286		A7R46,	A269	
A7Q11,			A7R47,		
A7Q12			A7R48		

**SECTION VI. INDEX-FEDERAL STOCK NUMBER CROSS REFERENCE TO INDEX NUMBER  
(CONTINUED)**

← FIG NO →	ITEM NO. OR REFERENCE DESIGNATION	← REF NO →	← FIG NO. →	ITEM NO. OR REFERENCE DESIGNATION	← INDEX NO. →
9-14	A7R49,	A270		A13Q10,	A3Q6A
	A7R50,			A13Q11,	
	A7R51			A13Q12	
	A7R52,	A271		A13Q13,	A326B
	A7R53,			A13Q14,	
	A7R54			A13Q15	
	A7R55,	A272		A13Q16,	A326A
	A7R56,			A13Q17,	
	A7R57			A13Q18	
	A7R58,	A268		A13Q19,	A326B
	A7R59,			A13Q20,	
	A7R60			A13Q21	
	A7R62	A273		A13Q22,	A326A
	A7R64,	A273		A13Q23,	
	A7R65			A13Q24	
	A7R67,	A270		A13Q25,	A326B
	A7R68,			A13Q26,	
	A7R69			A13Q27	
	A7R70,	A271		A13R1	A305
	A7R71,			A13R2	A306
	A7R72			A13R3	A305
A7R73,	A272		A13R4	A306	
A7R74,			A13R5	A305	
A7R75			A13R6	A306	
9-15	A13	A300		A13R7,	A307
	A13C1,	A318		A13R8,	
	A13C2,			A13R9	
	A13C3			A13R10,	A308
	A13C4	A319		A13R11,	
	A13C5	A321		A13R12	
	A13C6	A323		A13R13,	A309
	A13C7	A320		A13R14,	
	A13C8	A322		A13R15	
	A13C9	A324		A13R16,	A310
	A13C10	A319		A13R17,	
	A13C11	A321		AL3R18	
	A13C12	A323		A13R19,	A311
	A13C13	A320		A13R20,	
	A13C14	A322		A13R21	
	A13C15	A324		A13R22,	A312
	A13C16	A319		A13R23,	
	A13C17	A321		A13R24	
	A13C18	A323		A13R25,	A313
	A13C19	A320		A13R26,	
	A13C20	A322		A13R27	
	A13C21	A324		A13R28,	A309
	A13C22	A319		A13R29,	
	A13C23	A321		A13R30	
	A13C24	A323		A13R31,	A310
	A13C25	A320		A13R32,	
	A13C26	A322		A13R33	
	A13C27	A324		A13R34,	A311
	A13C28,	A326		A13R35,	
	A13C29			A13R36	
	A13C30 thru	A325		A13R37,	A312
	A13C35			A13R38,	
	A13E1 thru	A302		A13R39	
	A13E6			A13R40,	A313
A13Q1 thru	A326A		A13R41,		
A13Q6			A13R42		
A13Q7,	A326B		A13R43,	A309	
A13Q8,			A13R44,		
A13Q9			A13R45		

**SECTION VI. INDEX-FEDERAL STOCK NUMBER CROSS REFERENCE TO INDEX NUMBER  
(CONTINUED)**

<b>FIG NO</b>	<b>ITEM NO. OR REFERENCE DESIGNATION</b>	<b>REF NO</b>	<b>FIG NO.</b>	<b>ITEM NO. OR REFERENCE DESIGNATION</b>	<b>INDEX NO.</b>
9-15	A13R46, A13R47, A13R48 A13R49, A13R50, A13R51 A13R52, A13R53, A13R54 A13R55, A13R56, A13R57 A13R58, A13R59, A13R60 A13R61 A13R62 A13R63 A13R64 A13R65 A13R66 A13R67, A13R68, A13R69 A13R70, A13R71, A13R72 A13R73, A13R74, A13R75	A310  A311  A312  A313  A309  A315 A314 A316 A314 A317 A314 A311  A312  A313		A6R11 A6R12 A6R13 A6R14 A6R15, A6R16 A6R17, A6R18 A6R19 A6R20 A6R21 A6R22, A6R23 A6R24 A6R25, A6R26 A6R27 A6R28, A6R29 A6R30 A6R31 A6R32 A6R33 A6R34 A6R35 A6R36, A6R37 A6R38 A6R39 A6TP1, A6TP2, A6TP3	A692 A687 A693 A694 A693  A695  A693 A697 A695 A698  A699 A700  A693 A700  A693 A695 A693 A702 A693 A697 A687  A696 A701 A715
9-17	A6 A6A1, A6A2 A6C2 A6C3 A6C4 A6C5 A6C6 A6C7 A6C8 A6C9, A6C10 A6C11 A6C12 A6C13 A6C14 A6CR1 A6CR2 thru A6CR5 A6CR6 A6Q1 thru A6Q5 A6R1 A6R2 A6R3 A6R4 A6R5 A6R6 A6R7 A6R8 A6R9 A6R10	A681 A714  A703 A704 A705 A704 A703 A706 A707 A704  A708 A716 A709 A716 A710 A711  A712 A713  A683 A684 A685 A686 A687 A683 A688 A689 A690 A691	9-19	A12 A12A1, A12A2 A12C1 A12C2 A12C3 A12C4 A12C5, A12C6 A12C7 A12C8 A12C9 A12C10 A12C11 A12C12, A12C13 A12C14 A12C15 A12C16 A12C17, A12C18 A12C19, A12C20, A12C21 A12C23 A12C24, A12C25 A12CR1 A12CR2 A12CR3 thru A12CR12	A632 A680  A665 A666 A667 A668 A669  A677 A670 A671 A669 A672 A671  A669 A670 A667 A669  A667  A673 A669  A674 A676 A675



**SECTION VI. INDEX-FEDERAL STOCK NUMBER CROSS REFERENCE TO INDEX NUMBER  
(CONTINUED)**

<b>FIG NO</b>	<b>ITEM NO. OR REFERENCE DESIGNATION</b>	<b>REF NO</b>	<b>FIG NO.</b>	<b>ITEM NO. OR REFERENCE DESIGNATION</b>	<b>INDEX NO.</b>
9-19	A12Q1 thru A12Q4 A12Q5 A12Q6, A12Q7, A12Q8 A12Q9, A12Q10 A12R11 A12Q12 A12R1, A12R2 A12R3 A12R4 A12R5 A12R6 A12R7 A12R8 A12R9 A12R10 A12R11 A12R12 A12R13 A12R14 A12R15 A12R16 A12R17 A12R18, A12R19 A12R20 A12R21, A12R22 A12R23 A12R24, A12R25 A12R26 A12R27 A12R28, A12R29 A12R30 A12R31, A12R32 A12R34, A12R35 A12R36 A12R37 A12R38 A12R39 A12R40 A12R41 A12R42 A12R43 A12R44, A12R45, A12R46 A12R47 A12R48 A12R49 A12R50 A12R51 A12R52 A12R53, A12R54	A678  A679 A678  A679 A678 A679 A634  A635 A636 A637 A638 A639 A635 A640 A641 A642 A643 A644 A645 A646 A64 A637 A647  A648 A642  A633C A649  A650 A651 A652  A653 A637  A656  A640 A657 A653 A634 A658 A659 A634 A658 A634  A660 A661 A662 A663 A662 A634 A642	9-21	A12R55, A12R56 A12R57 A12R58, A12R59, A12R60 A12R61 A12R62, A664 A12R63 A12R64 A12R65, A12R66, A12R67  A3 A3C1, A3C2, A3C3 A3C4 A3C5 A3C6 A3C7 A3C8 A3C9 A3C10 A3C11 A3C12 A3C13 A3C14 A3C15 A3C16 A3C17 A3CL8 A3C19 A3C20 A3CR1 thru A3CR9 A3R1 thru A3Q4 A3Q5 A3Q6, A3Q7 A3RQ, A3Q9, A3Q10 A3Q11 thru A3Q15 A3R1 A3R2 A3R3 A3R4 A3R5 A3R6 A3R7 A3R8, A3R9, A3R10 A3R11 A3R12 A3R13 thru A3RP6 A3R17 A3R18	A649  A652 A664  A634  A634 A664  A861 A887  A888 A889 A890 A888 A891 A889 A890 A88 A891 A892 A893 A892 A894 A895 A896 A897 A90LA A898  A899  A900 A899  A900  A863 A864 A865 A866 A867 A868 A869 A870  A871 A864 A872  A868 A869

**SECTION VI. INDEX-FEDERAL STOCK NUMBER CROSS REFERENCE TO INDEX NUMBER  
(CONTINUED)**

← FIG NO →	ITEM NO. OR REFERENCE DESIGNATION	← REF NO →	← FIG NO. →	ITEM NO. OR REFERENCE DESIGNATION	← INDEX NO. →
9-21	A3R19	A873		A8M1	A858
	A3R20,	A866		A8Q1,	A856
	A3R21			A8Q2	
	A3R22	A873		A8Q3	A857
	A3R23	A874		A8Q4,	A856
	A3R24	A875		A8Q5,	
	A3R25	A869		A8Q6	
	A3R26	A876		A8Q7	A857
	A3R27	A864		A8Q8 thru	A856
	A3R28	A873		A8Q11	
	A3R29	A871		A8Q12	A857
	A3R30	A877		A8Q13 thru	A856
	A3R31	A878		A8Q16	
	A3R32	A879		A8R1	A802
	A3R33	A880		A8R2	A803
	A3R34	A881		A8R3 thru	A804
	A3R35	A882		A8R6	
	A3R36	A865		A8R7	A805
	A3R37	A871		A8R8	A806
	A3R38	A864		A8R9	A807
	A3R39	A883		A8R10	A808
	A3R40	A864		A8R11	A809
	A3R41	A884		A8R12	A810
	A3R42	A866		A8R13	A811
	A3R43	A875		A8R14	A809
	A3R44	A863		A8R15,	A811
	A3R45	A884		A8R16	
	A,3R46	A885		A8R17	A812
	A3R47	A886		A8R18	A813
	A3R48	A864		A8R19	A808
	A3R49	A873		A8R20,	A814
	A3TP1,	A901		A8R21	
A3TP2			A8R22	A802	
			A8R23	A815	
			A8R24	A802	
			A8R25	A816	
			A8R26,	A808	
			A8R27		
			A8R28	A805	
			A8R29	A813	
			A8R30	A817	
			A8R31	A818	
			A8R32,	A819	
			A8R33		
			A8R34	A820	
			A8R35	A821	
			A822		
			A8R38	A809	
			A8R39	A823	
			A8R40	A804	
			A8R41	A821	
			A8R42	A824	
			A8R43	A825	
			A8R44	A826	
			A8R45	A802	
			A8R46	A827	
			A8R47	A828	
			A8R48	A829	
			A8R49	A830	
			A8R50	A831	
			A8R51	A832	
			A8R52	A833	
			A8R53	A834	
9-23	A8	A800			
	A8A1	A859			
	A8C1	A843			
	A8C2	A844			
	A8C3	A845			
	A8C4	A846			
	A8C5	A843			
	A8C6	A847			
	A8C7,	A846			
	A8C8				
	A8C9	A848			
	A8C11,	A849			
	A8C11	A8R36			
	A8C12	A850			
	A8C13,	A851			
	A8C14				
	A8C15	A845			
	A8C16A,	A846			
	A8C16B				
	A8C17	A852			
A8C18	A845				
A8CR1 thru	A853				
A8CR14					
A8CR15	A854				
A8CR16	A853				
A8CR17	A854				
A8CR18,	A853				
A8CR19,					
A8CR20					

**SECTION VI. INDEX-FEDERAL STOCK NUMBER CROSS REFERENCE TO INDEX NUMBER  
(CONTINUED)**

<b>FIG NO</b>	<b>ITEM NO. OR REFERENCE DESIGNATION</b>	<b>REF NO</b>	<b>FIG NO.</b>	<b>ITEM NO. OR REFERENCE DESIGNATION</b>	<b>INDEX NO.</b>
9-23	A8R54 A8R55 A8R56 A8R57 A8R58, A8R59 A8R60 A8R61 A8R62 A8R63 A8R64 A8R65 A8R66 A8R67 A8R68 A8TP1, A8TP2, A8TP3	A835 A836 A837 A812 A838  A821 A839 A809 A837 A840 A841 A842 A808 A838 A860		A1M7 thru A1M11 A1Q1, A1Q2 A1Q3, A1Q4, A1Q5 A1R1 A1R2 A1R3 A1R4 A1R5 A1R6 A1R7 A1R8 A1R9 A1R10 A1R11 A1R12 A1R13 A1R14, A1R15 A1R16 A1R17 A1R18 A1R19 A1R20 A1R21 A1XDS1 thru A1XDS5	A018  A034  A035   A020 A020 A020 A020 A020 A021 A022 A022 A023 A024 A025 A026 A025 A028  A030 A036 A031 A029 A027 A037 A033
9-25	A10 A10C1 A10C2 A10M1 A10M2, A10M3 A10M4, A10M5 A10M6 A10M7 A10M8, A10M9 A10M10 thru A10M13 A10M14 thru A1021 A10R1, A10R2, A10R3 A10R4, A10R5	A335 A337 A338 A339 A340  A341  A340 A342 A341  A340  A341  A344	9-31	A11 A11CI, A11C2 A11C3, A11C4 A11C5 thru A1C88 A11C9, A11C10 A11CR1, A11CR2 A11CR3, A11CR4 A11Q1 thru A11Q4 A11Q5 A11Q6 A11Q7 A11Q8 A11Q10, A11Q11 A11Q13, A11Q4 A11Q5 thru A11Q18 A11R1, A11R2 A11R3 A11R5 A11R7, A11R8	A385 A395  A396  A397  A396  A390B  A411A  A392  A391 A393 A391 A393 A393  A393  A394  A398  A399 A399 A400
9-27	A9 A9C1 A9C2 A9CR1 thru A9CR26 A9M1 thru A9M8 A9R1 thru A9R13 A9R14	A327 A329 A330 A331  A332  A333  A334			
9-29	A1 A1C1 A1C2 A1C3 A1CR1 thru A1CR51 A1DS1 thru A1DS5 A1M1 A1M2 thru A1M6	A010 A012 A013 A032 A015  A016  A019 A017			

**SECTION VI. INDEX-FEDERAL STOCK NUMBER CROSS REFERENCE TO INDEX NUMBER  
(CONTINUED)**

← FIG NO →	ITEM NO. OR REFERENCE DESIGNATION	← REF NO →	← FIG NO. →	ITEM NO. OR REFERENCE DESIGNATION	← INDEX NO. →		
9-31	A11R9,	A401	9-36	A5R14	A371		
	A11R10			A5R15	A372		
	A11R11,	A400		A5R16	A373		
	A11R12			A5R17	A374		
	A11R13	A402		A5R18	A375		
	A11R14	A403		A5RL9	A376		
	A11R15	A402		A5R20	A377		
	A11R16	A403		A5R21	A378		
	A11R17	A398		A5R22	A377		
	A11R18	A404					
	A11R19	A398			C1,	A178	
	A11R20	A404			C2,		
	A11R21,	A405			C3,		
	A11R22				C4		
	A11R23,	A406			C5,	A180	
	A11R24				C6		
	A11R25,	A407			C7	A179	
	A11R26				C8	A176	
	A11R27,	A408			C9	A176	
	A11R28				C10	A176	
	A11R29,	A409			C11	A176	
	A11R30				CR1	A208	
	A11R31,	A408			CR2	A208	
	A11R32				CR13 thru	A174	
	A11R33	A410			CR17		
	A11R34	A411			E1 thru	A170	
	A11R35,	A410			E16		
	A11R36				FI	A077	
	A11R37	A411			FL1,	A169	
	A11R38	A410			FL2		
	9-33	A5		A345		J2	A070
		A5C1		A379		J3	A069
		A5C3		A379		J4	A070
		A5C4		A380		J5	A069
		A5C5		A381		J7,	A051
		A5C6		A382		J8	
		A5C7		A383		M1	A082
		A5C8		A384		M2	A089
A5CR1,		A359		Q1,	A209		
A5CR2				Q2			
A5CR3,		A360		Q3	A209		
A5CR4				R1	A202		
A5Q1,		A357		R2	A202		
A5Q2				R3	A203		
A5Q3		A356		R4	A081		
A5Q4		A355		R5	A059		
A5S6,		A355		R6	A058		
A5Q7				R7	A073		
A5Q8,		A358		R8	A067		
A5Q9				R9	A066		
A5R1		A361		R15	A173		
A5R2		A362		R16,	A175		
A5R4		A363		R17,			
A5R5		A364		R18			
A5R6		A363		S1	A072		
A5R7		A365		S2	A063		
A5R8		A366		S3	A078		
A5R9		A368		S4	A005		
A5R10		A362		S5	A062		
A5R11		A367		S6	A061		
A5R12		A369		S7	A004		
A5R13		A370		S8	A079		
				S9	A060		

**SECTION VI. INDEX-FEDERAL STOCK NUMBER CROSS REFERENCE TO INDEX NUMBER  
(CONTINUED)**

<b>FIG NO</b>	<b>ITEM NO. OR REFERENCE DESIGNATION</b>	<b>REF NO</b>	<b>FIG NO.</b>	<b>ITEM NO. OR REFERENCE DESIGNATION</b>	<b>INDEX NO.</b>		
9-36	S10	A005	9-42	A18R31	A794		
	S11	A075		A18R32	A789		
	S12	A080		A18R33	A796		
	S13	A071		A18R35	A798		
	S14	A071					
	S15	A068		A20	A288		
	S16	A061		A20C1	A295		
	T1	A177		A20R1	A296		
	TB3	A181		A20R2	A297		
	XF1	A076		A20R3	A298		
	A20R4			A299			
	9-38	A17		A738	A20R5	A299A	
		A17C1		A762	9-43	A19	A717
		A17R1,		A746			
		A17R2					
A17R3,		A747					
A17R4							
A17R5,		A748					
A17R6							
A17R7		A753					
A17R8		A749					
A17R9		A750					
A17RL0		A751					
A17R11		A752					
A17R12		A754					
A17R13		A755					
A17R14		A756					
A17R15		A757					
A17R16		A758					
A17R17		A759					
A17R18		A756					
A17R19		A760					
A17R20	A761						
9-40	A18	A763					
	A18C1	A799					
	A18R1,	A771					
	A18R2						
	A18R3,	A772					
	A18R4						
	A18R7,	A774					
	A18R8						
	A18R10	A775					
	A18R11	A776					
	A18R12	A777					
	A18R13,	A778					
	A18R14						
	A18R15	A780					
	A18R16	A795					
	A18R17	A781					
	A18R18	A782					
	A18R19	A783					
	A18R20	A784					
	A18R21	A785					
	A18R22	A786					
	A18R23	A787					
	A18R24	A788					
	A18R25	A789					
	A18R26	A790					
	AL8R27	A791					
	A18R28	A785					
	A18R29,	A793					
	A18R30						

**SECTION VII. INDEX-REFERENCE DESIGNATION CROSS REFERENCE  
TO INDEX NUMBER**

<b>REFERENCE DESIGNATION</b>	<b>INDEX NO.</b>	<b>REFERENCE DESIGNATION</b>	<b>INDEX NO.</b>	<b>REFERENCE DESIGNATION</b>	<b>INDEX NO.</b>
A1	A010	A1R13	A025	A2L1	A107
A1C1	A012	A1R14, A1R15	A028	A2L2	A107
A1C2	A013	A1R16	A030	A2L3	A108
A1C3	A032	A1R17	A036	A2P1	A126A
A1CR1 thru A1CR51	A015	A1R18	A031	A2Q1, A2Q2	A109
A1DS1 thru A1DS5	A016	A1R19	A029	A2R1	A110
A1J1	A046	A1R20	A027	A2R2	A111
A1M1	A019	A1R21	A037	A2R3	A112
A1M2 thru A1M6	A017	A1XDS1 thru A1XDS5	A033	A2R4	A113
A1M7 thru A1M11	A018	A2	A097	A2R5	A114
A1P1	A049	A2C1	A099	A2R6	A111
A1Q1, A1Q2	A034	A2C2	A100	A2R7	A112
A1Q3, A1Q4, A1Q5	A035	A2C3	A101	A2R8	A115
A1R1	A020	A2C4	A102	A2S5	A131
A1R2	A020	A2C5	A102	A2XA3 thru A2XA9	A234
A1R3	A020	A2C6	A103	A2XA19	A234
A1R4	A020	A2C7	A099	A3	A861
A1R5	A020	A2C8	A104	A3C1, A3C2, A3C3	A887
A1R6	A021	A2C9	A099	A3C4	A888
A1R7	A022	A2C10	A104	A3C5	A889
A1R8	A022	A2C12	A103	A3C6	A890
A1R9	A023	A2C15, A2C16	A139	A3C7	A888
A1R10	A024	A2CR1	A106	A3C8	A891
A1R11	A025	A2CR2	A106	A3C9	A889
A1R12	A026	A2J1	A123	A3C10	A890
		A2J2	A127	A3C11	A888
		A2J6, A2J7	A216	A3C12	A891

**SECTION VII. INDEX-REFERENCE DESIGNATION CROSS REFERENCE  
TO INDEX NUMBER (CONTINUED)**

<b>REFERENCE DESIGNATION</b>	<b>INDEX NO.</b>	<b>REFERENCE DESIGNATION</b>	<b>INDEX NO.</b>	<b>REFERENCE DESIGNATION</b>	<b>INDEX NO.</b>
A3C13	A892	A3R17	A868	A3R47	A886
A3C14	A893	A3R18	A869	A3R48	A864
A3C15	A892	A3R19	A873	A3R49	A873
A3C16	A894	A3R20,	A866	A3TP1, A3TP2	A901
A3R21					
A3C17	A895	A3R22	A873	A4	A412
A3C18	A896	A3R23	A874	A4C1	A416
A3C19	A897	A3R24	A875	A4C2	A417
A3C20	A901A	A3R25	A869	A4C3	A416
A3CR1 thru A3CR9	A898	A3R26	A876	A4C4	A419
A3Q1 thru A3Q4	A899	A3R27	A864	A4C5	A417
		A3R28	A873	A4C6	A416
A3Q5	A900	A3R29	A871	A4C7	A418
A3Q6, A3Q7	A899	A3R30	A877	A4C8, A4C9	A416
A3Q8, A3Q9, A3Q10	A900	A3R31	A878	A4C10	A420
	A3R32		A879	A4C11 thru AC421	A416
A3Q11 thru A3Q15	A899	A3R33	A880	A4C16	A421
		A3R34		A4C17, A4C18, A4C19	A416
A3R1	A863	A3R35	A882	A4C20	A422
A3R2	A864	A3R36	A865	A4C21	A421
A3R3	A865	A3R37	A871	A4C22	A422
A3R4	A866	A3R38	A864	A4C23	A421
A3R5	A867	A3R39	A883	A4C24, A4C25, A4C26	A416
A3R6	A868	A3R40	A864	A4C27, A4C28	A419
A3R7	A869	A3R41	A884	A4C30	A416
A3R8, A3R9 A3R10	A870	A3R42	A866	A4C31	A422
A3R11	A871	A3R43	A875		
A3R12	A864	A3R44	A863		
A3R13 thru A3R16	A872	A3R45	A884		
		A3R46	A885		

**SECTION VII. INDEX-REFERENCE DESIGNATION CROSS REFERENCE  
TO INDEX NUMBER (CONTINUED)**

REFERENCE DESIGNATION	INDEX NO.	REFERENCE DESIGNATION	INDEX NO.	REFERENCE DESIGNATION	INDEX NO.
A4C33	A4161	A4R8	A440	A4R38	A463
A4C34	A425	A4R9	A441	A4R39	A464
A4C35	A416	A4R10	A442	A4R40	A463
A4C36	A421	A4R11	A443	A4R41	A465
A4C37	A416	A4R12, A4R13	A44	A4R44	A443
A4C38	A421	A4R14	A445	A4R45	A445
A4C39	A416	A4R15	A446	A4R46	A443
A4C40	A425	A4R16	A447	A4R47	A446
A4C41	A420	A4R17	A444	A4R48	A442
A4C42	A419	A4R18	A448	A4TP1	A472
A4C44	A416	A4R19	A449	A4XY1	A467
A4CR1	A426	A4R20	A450	A4Y1	A466
A4CR2, A4CR3, A4CR4	A427	A4R21	A451	A5	A345
A4CR5	A428	A4R22	A452	A5C1	A379
A4L1	A429	A4R23	A453	A5C3	A379
A4L2, A4L3	A430	A4R24	A454	A5C4	A380
A4L4	A433	A4R25	A451	A5C5	A381
A4Q1, A4Q2	A431	A4R26	A455	A5C6	A382
A4Q3	A432	A4R27	A456	A5C7	A383
A4Q4 thru A4Q15	A431	A4R28, A4R29	A457	A5C8	A384
A4R1, A4R2	A434	A4R30	A452	A5CR1, A5CR2	A359
A4R3	A435	A4R31, A4R32	A458	A5CR3, A5CR4	A360
A4R4	A436	A4R33	A459	A5Q1, A5Q2	A357
A4R5	A437	A4R34	A460	A5Q3	A356
A4R6	A438	A4R35	A435	A5Q4	A355
A4R7	A439	A4R36	A461	A5Q6, A5Q7	A355
		A4R37	A462	A5Q8, A5Q9	A358



**SECTION VII. INDEX-REFERENCE DESIGNATION CROSS REFERENCE  
TO INDEX NUMBER (CONTINUED)**

<b>REFERENCE DESIGNATION</b>	<b>INDEX NO.</b>	<b>REFERENCE DESIGNATION</b>	<b>INDEX NO.</b>	<b>REFERENCE DESIGNATION</b>	<b>INDEX NO.</b>
A5R1	A3611	A6C7	A706	A6R17, A6R18	A695
A5R2	A362	A6C8	A707	A6R19	A693
A5R4	A363	A6C9, A6C10	A704	A6R20	A697
A5R5	A364	A6C11	A708	A6R21	A695
A5R6	A363	A6C12	A716	A6R22, A6R23	A698
A5R7	A365	A6C13	A709	A6R24	A699
A5R8	A366	A6C14	A716	A6R25, A6R26	A700
A5R9	A368	A6CR1	A710	A6R27	A693
A5R10	A362	A6CR2 thru A6CR5	A711	A6R28, A6R29	A700
A5R11	A367	A6CR6	A712	A6R30	A693
A5R12	A369	A6Q1 thru A6Q5	A713	A6R31	A695
A5R13	A370	A6R1	A683	A6R32	A693
A5R14	A371	A6R2	A684	A6R33	A702
A5R15	A372	A6R3	A685	A6R34	A693
A5R16	A373	A6R4	A686	A6R35	A697
A5R17	A374	A6R5	A687	A6R36, A6R37	A687
A5R18	A375	A6R6	A683	A6R38	A696
A5R19	A376	A6R7	A688	A6R39	A701
A5R20	A377	A6R8	A689	A6TP1, A6TP2, A6TP3	A715
A5R21	A378	A6R9	A690	A7	A259
A5R22	A377	A6R10	A691	A7C1, A7C2, A7C3	A277
A6	A681	A6R11	A692	A7C4	A278
A6A1, A6A2	A714	A6R12	A687	A7C5	A280
A6C2	A703	A6R13	A693		
A6C3	A704	A6R14	A694		
A6C4	A705	A6R15, A6R16	A693		
A6C5	A704				
A6C6	A703				

**SECTION VII. INDEX-REFERENCE DESIGNATION CROSS REFERENCE  
TO INDEX NUMBER (CONTINUED)**

<b>REFERENCE DESIGNATION</b>	<b>INDEX NO.</b>	<b>REFERENCE DESIGNATION</b>	<b>INDEX NO.</b>	<b>REFERENCE DESIGNATION</b>	<b>INDEX NO.</b>
A7C6	A282	A7Q7, A7Q8, A7Q9	A287	A7R19, A7R20, A7R21	A270
A7C7	A279				
A7C8	A281	A7Q10, A7Q11, A7Q12	A286	A7R22, A7R23, A7R24	A271
A7C9	A283				
A7C10	A278	A7Q13, A7Q14, A7Q15	A287	A7R25, A7R26, A7R27	A272
A7C11	A280				
A7C12	A282	A7Q16, A7Q17, A7Q18	A286	A7R28, A7R29, A7R30	A268
A7C13	A279				
A7C14	A281	A7Q19, A7Q20, A7Q21	A287	A7R31, A7R32, A7R33	A269
A7C15	A283				
A7C16	A278	A7Q22, A7Q23, A7Q24	A286	A7R34, A7R35, A7R36	A270
A7C17	A280				
A7C18	A282	A7Q25, A7Q26, A7Q27	A287	A7R37, A7R38, A7R39	A271
A7C19	A279				
A7C20	A281	A7R1	A264	A7R40, A7R41, A7R42	A272
A7C21	A283	A7R2	A265		
A7C22	A278	A7R3	A264	A7R43, A7R44, A7R45	A268
A7C23	A280	A7R4	A265		
A7C24	A282	A7R5	A264	A7R46, A7R47, A7R48	A269
A7C25	A279	A7R6	A265		
A7C26	A281	A7R7, A7R8, A7R9	A266	A7R49, A7R50, A7R51	A270
A7C27	A283				
A7C28, A7C29	A285	A7R10, A7R11, A7R12	A267	A7R52, A7R53, A7R54	A271
A7C30 thru A7C35	A284	A7R13, A7R14, A7R15	A268	A7R55, A7R56, A7R57	A272
A7E1 thru A7E5	A261				
A7Q1 thru A7Q6	A286	A7R16, A7R17, A7R18	A269	A7R58, A7R59, A7R60	A268

**SECTION VII. INDEX-REFERENCE DESIGNATION CROSS REFERENCE  
TO INDEX NUMBER (CONTINUED)**

<b>REFERENCE DESIGNATION</b>	<b>INDEX NO.</b>	<b>REFERENCE DESIGNATION</b>	<b>INDEX NO.</b>	<b>REFERENCE DESIGNATION</b>	<b>INDEX NO.</b>
A7R62	A273	A8CR15	A854	A8R17	A8112
A7R64, A7R65	A273	A8CR16	A853	A8R18	A813
A7R67, A7R68, A7R69	A270	A8CR17	A854	A8R19	A808
A7R70, A7R71, A7R72	A271	A8CR18, A8CR19, A8CR20	A853	A8R20, A8R21	A814
A7R73, A7R74, A7R75	A272	A8M1	A858	A8R22	A802
A8	A800	A8Q1, A8Q2	A856	A8R23	A815
A8A1	A859	A8Q3	A857	A8R24	A802
A8C1	A843	A8Q4, A8Q5, A8Q6	A856	A8R25 A8R26, A8R27	A816 A808
A8C2	A844	A8Q7	A857	A8R28	A805
A8C3	A845	A8Q8 thru A8Q11	A856	A8R29	A813
A8C4	A846	A8Q12	A857	A8R30	A817
A8C5	A843	A8Q13 thru A8Q16	A856	A8R31	A818
A8C6	A847	A8R1	A802	A8R32, A8R33	A819
A8C7, A8C8	A846	A8R2	A803	A8R34 A8R35	A820 A821
A8C9	A848	A8R3 thru A8R6	A804	A8R36	A822
A8C10, A8C11	A849	A8R7	A805	A8R38	A809
A8C12	A850	A8R8	A806	A8R39	A823
A8C13, A8C14	A851	A8R9	A807	A8R40	A804
A8C15	A845	A8R10	A808	A8R41	A821
A8C16A, A8C16B	A846	A8R11	A809	A8R42	A824
A8C17	A852	A8R12	A810	A8R43	A825
A8C18	A845	A8R13	A811	A8R44	A826
A8CR1 thru A8CR14	A853	A8R14	A809	A8R45	A802
		A8R15, A8R16	A811	A8R46	A827
				A8R47	A828

**SECTION VII. INDEX-REFERENCE DESIGNATION CROSS REFERENCE  
TO INDEX NUMBER (CONTINUED)**

<b>REFERENCE DESIGNATION</b>	<b>INDEX NO.</b>	<b>REFERENCE DESIGNATION</b>	<b>INDEX NO.</b>	<b>REFERENCE DESIGNATION</b>	<b>INDEX NO.</b>
A8R48	A829	A9R1 thru A9R13	A333	A11CR3, A11CR4	A411A
A8R49	A830	A9R14	A334	A11Q1 thru A11Q4	A392
A8R50	A831	A10	A335	A11Q5	A391
A8R51	A832	A10C1	A337	A11Q6	A393
A8R52	A833	A10C2	A338	A11Q7	A391
A8R53	A834	A10M1	A339	A11Q8	A393
A8R54	A835	A10M2, A10M3	A340	A11Q10, A11Q11	A393
A8R55	A836	A10M4, A10M	A341	A11Q13, A11Q14	A393
A8R56	A837	A10M6	A340	A11Q15 thru A11Q18	A394
A8R57	A812	A10M7	A342	A11R1, A11R2	A398
A8R58, A8R59 A8R60	A838 A821	A10M8, A10M9	A341	A11R3	A399
A8R61	A839	A10M10 thru A10M13	A340	A11R5	A399
A8R62	A809	A10114 thru A10M21	A341	A11R7, A11R8	A400
A8R63	A837	A10R1, A10R2, A10R3	A343	A11R9, A11R10	A401
A8R64	A840	A10R4, A10R5	A344	A11R11, A11R12	A400
A8R65	A841	A11	A385	A11R13	A402
A8R66	A842	A11C1, A11C2	A395	A11R14	A403
A8R67	A808	A11C3, A11C4	A396	A11R15	A402
A8R68	A838	A11C5 thru A11C8	A397	A11R16 A11R17	A403 A398
A8TP1, A8TP2, A8TP3	A860	A11C9, A11C10	A396	A11R18	A404
A9	A327	A11CR1, A11CR2	A390B	A11R19	A398
A9C1	A329			A11R20	A404
A9C2	A330			A11R21, A11R22	A405
A9CR1 thru A9CR26	A331				
A9M1 thru A9M8	A332				

**SECTION VII. INDEX-REFERENCE DESIGNATION CROSS REFERENCE  
TO INDEX NUMBER (CONTINUED)**

<b>REFERENCE DESIGNATION</b>	<b>INDEX NO.</b>	<b>REFERENCE DESIGNATION</b>	<b>INDEX NO.</b>	<b>REFERENCE DESIGNATION</b>	<b>INDEX NO.</b>
A11R23, A11R24	A406	A12C15	A670	A12R10	A641
		A12C16	A667	A12R11	A642
A11R25, A11R26	A407	A12C17, A12C18	A669	A12R12	A643
A11R27, A11R28	A408	A12C19, A12C20, A12C21	A667	A12R13	A644
A11R29, A11R30	A409			A12R14	A615
		A12C23	A673	A12R15	A646
A11R31, A11R32	A408	A12R16	A640		
		A12C24, A12C25	A669	A12R17	A637
A11R33	A410				
A11R34	A411	A12CR1	A674	A12R18, A12R19	A647
		A12CR2	A676		
A11R35, A11R36	A410	A12CR3 thru A12CR12	A675	A12R20	A648
A11R37	A411			A12R21, A12R22	A642
A11R38	A410	A12Q1 thru	A678		
A12	A632	A12Q4		A12R23	A633C
		A12Q5	A679	A12R24, A12R25	A649
A12A1, A12A2	A680	A12Q6, A12Q7, A12Q8	A678		
				A12R26	A650
A12C1	A665				
		A12Q9, A12Q10	A679	A12R27	A651
A12C2	A666			A12R28, A12R29	A652
A12C3	A667	A12Q11	A678		
A12C4	A668	A12Q12	A679	A12R30	A653
A12C5, A12C6	A669	A12R1, A12R2	A634	A12R31, A12R32	A637
A12C7	A677	A12R3	A635	A12R34, A12R35	A656
A12C8	A670	A12R4	A636	A12R36	A640
A12C9	A671	A12R5	A637	A12R37	A657
A12C10	A669	A12R6	A638	A12R38	A653
A12C11	A672	A12R7	A639	A12R39	A634
A12C12, A12C13	A671	A12R8	A635	A12R40	A658
A12C14	A669	A12R9,	A640	A12R41	A659

**SECTION VII. INDEX-REFERENCE DESIGNATION CROSS REFERENCE  
TO INDEX NUMBER (CONTINUED)**

← REFERENCE DESIGNATION →	INDEX NO. ← →	← REFERENCE DESIGNATION →	INDEX NO. ← →	← REFERENCE DESIGNATION →	INDEX NO. ← →
A12R42	A634	A13C8	A322	A13Q10, A13Q11,	A326A
A12R43	A658	A13C9	A324	A13Q12	
A12R44, A12R45, A12R46 A12R47	A634	A13C10	A319	A13Q13, A13Q14, A13Q15	A326B
	A660	A13C11	A321	A13Q16, A13Q17,	A326A
A12R48	A661	A13C12	A323	A13Q18	
A12R49	A662	A13C13	A320	A13Q19, A13Q20,	A326B
		A13C14	A322	A13Q21	
A12R50	A663	A13C15	A324	A13Q22, A13Q23,	A326A
A12R51	A662	A13C16	A319	A13Q24	
				A13Q25, A13Q26, A13Q27	A326B
A12R52	A634	A13C17	A321		
A12R53, A12R54	A642	A13C18	A323	A13R1	A305
		A13C19	A320	A13R2	A306
A12R55, A12R56	A649	A13C20	A322	A13R3	A305
A12R57	A652	A13C21	A324	A13R4	A306
A12R58, A12R59, A12R60	A664	A13C22	A319	A13R5	A305
A12R61	A634	A13C23	A321	A13R6	A306
A12R62, A12R63	A664	A13C24	A323		
		A13C25	A320	A13R7, A13R8, A13R9	A307
A12R64	A634	A13C26	A322	A13R10, A13R11, A13R12	A308
		A13C27	A324		
A12R65, A12R66, A12R67	A664	A13C28, A13C29	A326	A13R13, A13R14, A13R15	A309
A13	A300	A13C30 thru A13C35	A325	A13R16, A13R17, A13R18	A310
A13C1, A13C2, A13C3	A318	A13E1 thru A13E6	A302		
A13C4	A319	A13Q1 thru A13Q6	A326A	A13R19, A13R20, A13R21	A311
A13C5	A321	A13Q7, A13Q8, A13Q9	A326B		
A13C6	A323				
A13C7	A320				

**SECTION VII. INDEX-REFERENCE DESIGNATION CROSS REFERENCE  
TO INDEX NUMBER (CONTINUED)**

<b>REFERENCE DESIGNATION</b>	<b>INDEX NO.</b>	<b>REFERENCE DESIGNATION</b>	<b>INDEX NO.</b>	<b>REFERENCE DESIGNATION</b>	<b>INDEX NO.</b>
A13R22, A13R23, A13R24	A312	A13R63	A316	A14C21	A521
A13R25, A13R26, A13R27	A313	A13R64	A314	A14C22	A519
A13R28, A13R29, A13R30	A309	A13R65	A317	A14C23	A521
A13R31, A13R32, A13R33	A310	A13R66	A314	A14C24	A519
		A13R67, A13R68, A13R69	A311	A14C25	A521
		A13R70, A13R71, A13R72	A312	A14C26	A530
				A14C27	A528
A13R34, A13R35, A13R36	A311	A13R73, A13R74, A13R75	A313	A14C28 thru A14C31	A529
				A14C32	A520
A13R37, A13R38, A13R39	A312	A14	A483	A14CR1	A533
A14L1		A14C2	A519	A14CR2	A536
A13R40, A13R41, A13R142	A313	A14C3	A524		A534
A13R43, A13RA45	A309	A14C4	A521	A14L2, A14L3	A535
A13R46, A13R47, A13R48	A310	A14C6	A521	A14L4	A534
		A14C7	A522	A14L5	A541A
		A14C8, A14C9	A521	A14Q1	A531
				A14Q3	A531
A13R49, A13R50, A13R51	A311	A14C10	A523	A14Q5	A531
		A14C11	A524	A14Q7 thru A14Q11	A531
		A14C12	A521		
A13R52, A13R53, A13R54	A312	A14C13	A525	A14Q12	A532
		A14C14	A526	A14Q13, A14Q14, A14Q15	A531
A13R55, A13R56, A13R57	A313	A14C15	A521		
		A14C16	A527	A14Q16	A532
A13R58, A13R59, A13R60	A309	A14C17	A521	A14Q17, A14Q18	A531
		A14C18	A522		
A13R61	A315	A14C19	A528	A14R1	A487AC
A13R62	A314	A14C20	A529	A14R3	A488

**SECTION VII. INDEX-REFERENCE DESIGNATION CROSS REFERENCE TO INDEX NUMBER (CONTINUED)**

<b>REFERENCE DESIGNATION</b>	<b>INDEX NO.</b>	<b>REFERENCE DESIGNATION</b>	<b>INDEX NO.</b>	<b>REFERENCE DESIGNATION</b>	<b>INDEX NO.</b>
A14R5	A489	A14R40	A510	A15C11	A579
A11R9	A490	A14R41	A505	A15C12	A576
A14R13	A491	A14R42	A508	A15C13	A580
A14R14	A492	A14R43	A511	A15C14	A581
A14R15	A493	A14R44	A492	A15C15	A576
A14R17	A501	A14R45	A508	A15C16	A582
A14R18	A513	A14R46	A499	A15C17	A576
A14R19	A487AC	A14R47	A500	A15C18	A577
A14R20	A494	A14R48	A502	A15C19	A575
A14R21	A495	A14R49	A503	A15C20	A576
A14R22	A496	A14R50	A514	A15C23	A584
A14R23	A497	A14R51	A515	A15C24	A574
A14R24	A487AC	A14R52	A516	A15C25	A576
A11R25	A498	A14R53	A517	A15C26	A583
A14R26	A513	A14R54	A514	A15C27	A575
A14R27	A499	A14R55	A510	A15CR1	A587
A14R28	A500	A14R56	A492	A1511	A588
A14R29	A490	A14R57	A518	A1512	A589
A14R30	A501	A14R58	A495	A1513	A590
A14R31	A502	A14R59	A512	A1514	A588
A14R32	A503	A15	A542	A15Q1	A585
A14R33	A496	A15C2	A574	A15Q3	A585
A14R34	A504	A15C3, A15C4	A576	A15Q5	A585
A14R35	A506	A15C6	A576	A15Q7 thru A15Q11	A585
A14R36	A507	A15C7	A577	A15Q12	A586
A14R37	A508	A15C8,	A576	A15Q13,	A585
A14R38	A509	A15C9		A15Q14, A15Q15	
A14R39	A489	A15C10	A578	A15Q16	A586



**SECTION VII. INDEX-REFERENCE DESIGNATION CROSS REFERENCE TO INDEX NUMBER (CONTINUED)**

<b>REFERENCE DESIGNATION</b>	<b>INDEX NO.</b>	<b>REFERENCE DESIGNATION</b>	<b>INDEX NO.</b>	<b>REFERENCE DESIGNATION</b>	<b>INDEX NO.</b>
A15Q17, A15Q18	A585	A15R38	A564	A16C6	C624
A15RR1	A547	A15R39	A547	A16C7	C620
A15R3	A547A	A15R40	A565	A16C8	A625
A15R5	A547B	A15R42	A563	A16C9	A622
A15R9	A547C	A15R43	A566	A16C10	A631E
A15R13	A548	A15R44	A549	A16CR1 thru A16CR4	A626
A15R14	A549	A15R45	A563	A16M1	A627
A15R15	A550	A15R46	A556	A16M2	A628
A15R17	A558	A15R47	A557	A16Q1	A629
A15R18	A567	A15R48	A559	A16Q2	A630
A15R19	A547	A15R49	A560	A16Q3	A629
A15R20	A551	A15R50	A565	A16Q4, A16Q5	A630
A15R21	A552	A15R51	A569	A16Q6	A629
A15R22	A553	A15R52	A570	A16Q7 thru A16Q11	A630
A15R23	A554	A15R53	A571	A16Q12	A629
A15R24	A547	A15R54	A568	A16Q14	A629
A15R25	A555	A15R55	A572	A16Q15	A630
A15R26	A567	A15R56	A549	A16Q16	A629
A15R27	A556	A15R57	A573	A16R1	A631A
A15R28	A557	A15R58	A552	A16R2	A599
A15R29	A557	A15R59	A554	A16R3	A631B
A15R30	A558	A15R60	A591	A16R4	A601
A15R31	A559	A16	A597	A16R5	A631C
A15R32	A560	A16C1	A620	A16R6	A631B
A15R35	A561	A16C2	A621	A16R7	A603
A15R36	A562	A16C3	A620	A16R8	A604
A15R37	A563	A16C4	A622	A16R9	
		A16C5	A623		

**SECTION VII. INDEX-REFERENCE DESIGNATION CROSS REFERENCE TO INDEX NUMBER (CONTINUED)**

<b>REFERENCE DESIGNATION</b>	<b>INDEX NO.</b>	<b>REFERENCE DESIGNATION</b>	<b>INDEX NO.</b>	<b>REFERENCE DESIGNATION</b>	<b>INDEX NO.</b>
A16R10	A605	A16R43	A61T	A18	A763
A16R11	A606	A16R44	A600	A18C1	A799
A16R12	A607	A16R45	A618	A18E1 thru A18E27	A770
A16R13	A604	A16R46	A602	A18R1,	A771
A16R14	A608	A16R47	A599	A18R2	
A16R15	A609	A16R48, A16R49	A619	A18R3, A18R4	A772
A16R16	A600	A16R50	A631D	A18R7,	A774
A16R17	A604	A16TP1, A16TP2, A16TP3	A631	A18R8	
A16R18	A605	A17	A738	A18R10	A775
A16R19, A16R20	A610	A17C1	A762	A18R11	A776
A16R21	A602	A17E1 thru A17E21	A745	A18R12	A777
A16R22	A611	A17R1, A17R2	A746	A18R13, A18R14	A778
A16R23	A600	A17R3, A17R4	A747	A18R15	A780
A16R24	A604	A17R5, A17R6	A748	A18R16	A795
A16R25	A610	A17R7	A753	A18R17	A781
A16R26	A612	A17R8	A749	A18R18	A782
A16R27	A613	A17R9	A750	A18R19	A783
A16R28	A602	A17R10	A751	A18R20	A784
A16R29	A608	A17R11	A752	A18R21	A785
A16R30	A605	A17R12	A754	A18R22	A786
A16R31	A614	A17R13	A755	A18R23	A787
A16R32	A604	A17R14	A756	A18R24	A788
A16R33	A615	A17R15	A757	A18R25	A789
A16R34	A600	A17R16	A758	A18R26	A790
A16R35	A605	A17R17	A759	A18R27	A791
A16R36	A611	A17R18	A756	A18R28	A785
A16R37	A616	A17R19	A760	A18R29, A18R30	A793
A16R38, A16R39	A605	A17R20	A761	A18R31	A794
A16R40	A617			A18R32	A789
A16R41	A600			A18R33	A796
A16R42	A605			A18R35	A798

**SECTION VII. INDEX-REFERENCE DESIGNATION CROSS REFERENCE TO INDEX NUMBER(CONTINUED)**

<b>REFERENCE DESIGNATION</b>	<b>INDEX NO.</b>	<b>REFERENCE DESIGNATION</b>	<b>INDEX NO.</b>	<b>REFERENCE DESIGNATION</b>	<b>INDEX NO.</b>
A19	A717	J1	A189	S6	A061
A19T2, A19T3	A733	J2	A070	S7	A004
A20	A288	J3	A069	S8	A079
A20C1	A295	J4	A070	S9	A060
A20E1 thru A20E6	A295	J5	A069	S10	A005
A20R1	A296	J7, J8	A051	S11	A075
A20R2	A297	J11, J12	A216	S12	A080
A20R3	A298	M1	A082	S13	A071
A20R4	A299	M2	A089	S14	A071
A20R5	A299A	Q1, Q2	A209	S15	A068
C1	A178	Q3		S16	A061
C2	A178	R1	A209	T1	A177
C3	A178	R2	A202	TB1, TB2	A194
C4	A178	R3	A202	TB3	A181
C5	A180	R4	A203	XA10 thru XA16	A221
C6	A180	R5	A081	XDS1	A092
C7	A179	R6	A059	XF1	A076
C8	A176	R7	A058	XQ1, XQ2, XQ3	A210
C9	A176	R8	A073		
C10	A176	R9	A067		
C11	A176	R15	A066		
CR1	A208	R16, R17, R18	A173		
CR2	A208	S1	A175		
CR13 thru CR17	A174	S2	A072		
E1 thru E16	A170	S3	A063		
F1	A077	S4	A078		
FL1, FL2	A169	S5	A005		
TS-2669/GCM D-67			A062		

By Order of the Secretary of the Army:

W. C. WESTMORELAND,  
*General, United States Army,*  
*Chief of Staff.*

Official:

KENNETH G. WICKHAM,  
*Major General, United States Army,*  
*The Adjutant General.*

Distribution:

*Active Army:*

CNGB (1)  
 CofEngrs (1)  
 TSG (1)  
 CofSptS (1)  
 ACSC-E (2)  
 USAMB (10)  
 USAARENBD (2)  
 USAARTYBD (2)  
 USCONARC (2)  
 USAMC (2)  
 USAMICOM (2)  
 USAECOM (2)  
 ARADCOM (2)  
 ARADCOM Rgn (1)  
 OS Maj Comd (2)  
 USACDCEC (10)  
 USASTRATCOM (2)  
 USAESC (70)  
 USATECOM (2)  
 Armies (1)  
 Sig FLDMS (1)  
 USASESS (10)  
 USAINTS (3)  
 USASA (2)  
 USACDCCEA (1)  
 USACDCCEA  
 Ft Huachuca (1)

LBAD (14)  
 SAAD (30)  
 TOAD (14)  
 LEAD (7)  
 NAAD (3)  
 SVAD (3)  
 ATAD (10)  
 Svc Colleges (1)  
 1st Cav Div (2)  
 GENDEP (1)  
 Sig Sec GENDEP (4)  
 Sig Dep (6)  
 USACRREL (2)  
 Ft Huachuca (5)  
 WSMR (2)  
 Ft Carson (7)  
 USAERDAA (2)  
 USAERDAW (2)  
 Units org under the fol TOE:  
 (one (1) cy ea unit)  
 11-155  
 11-157  
 11-158  
 11-347  
 11-587  
 11-592  
 11-597  
 29-134

NG: State AG (3).

USAR: None.

For explanation of abbreviations used, see AR 32040.

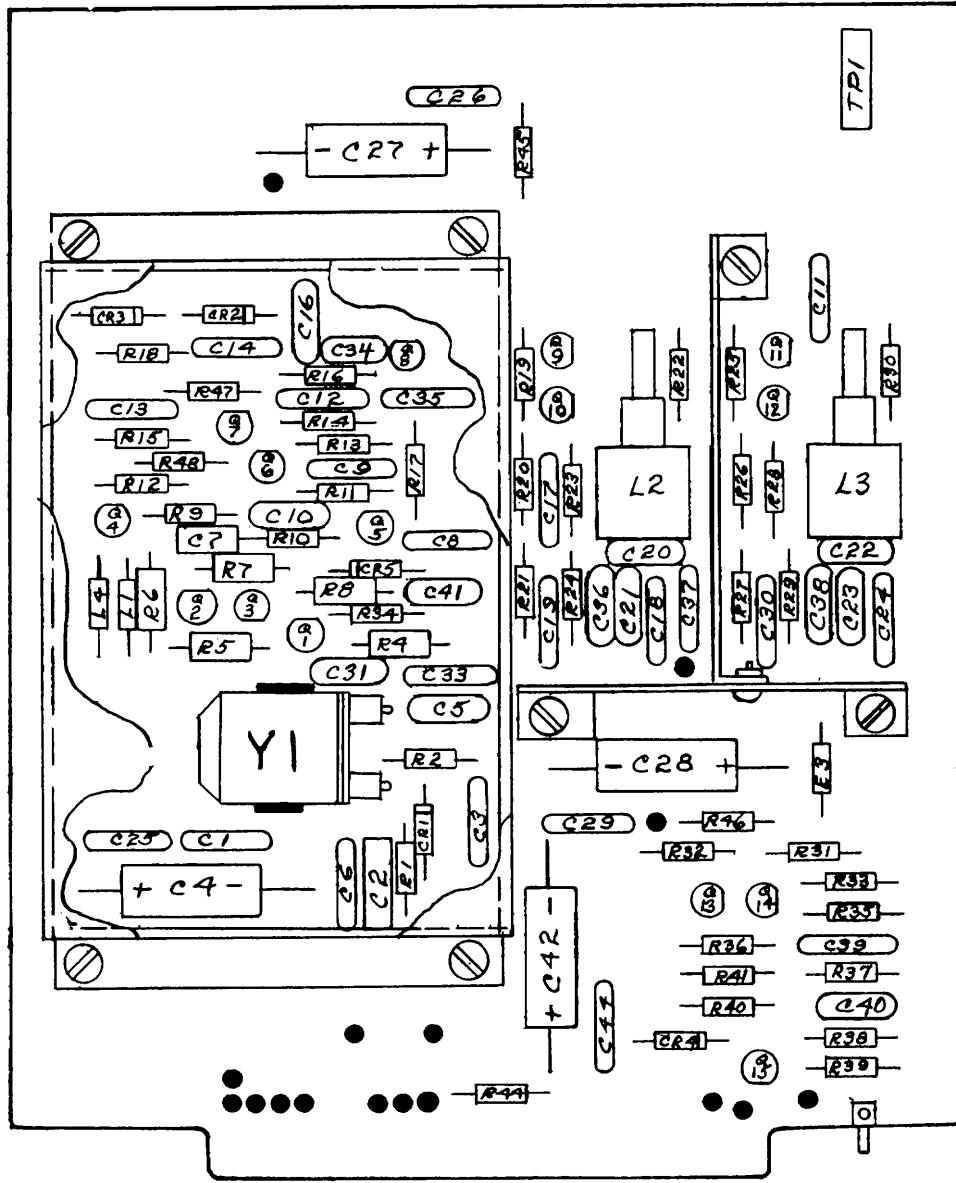

EL 6625-922-15-21

Figure 9-4. 2-MHz oscillator (A4), C-4696, location of components.

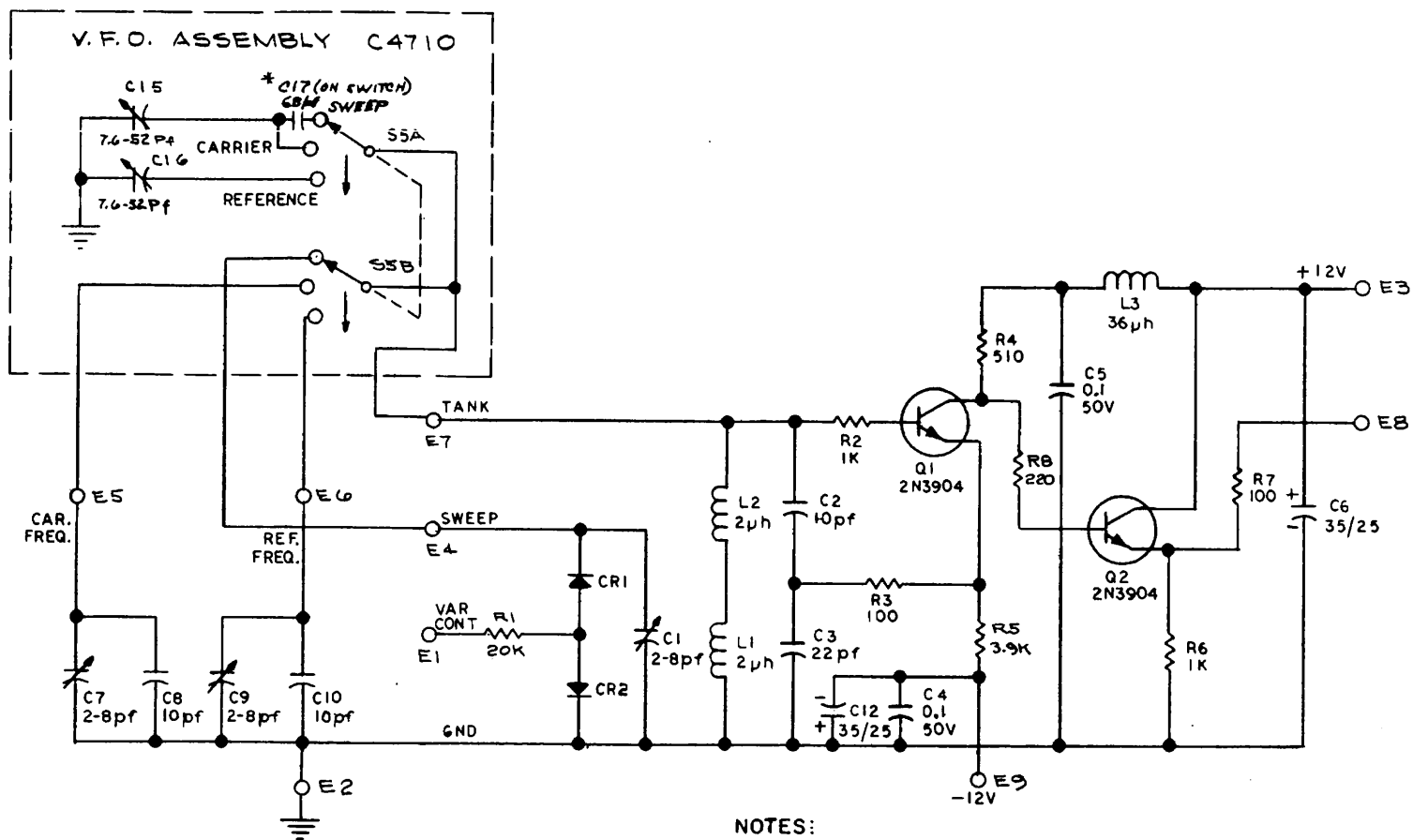

- NOTES:
1. UNLESS OTHERWISE SPECIFIED:  
RESISTORS ARE IN OHMS 1/4W, 5%  
CAPACITORS ARE IN MICROFARADS, 500V.
  2. CR1 AND CR2 ARE IN4809A.

EL 6625-922-15-22

Figure 9-5. Variable-frequency oscillator (A2), D-4710, schematic diagram.

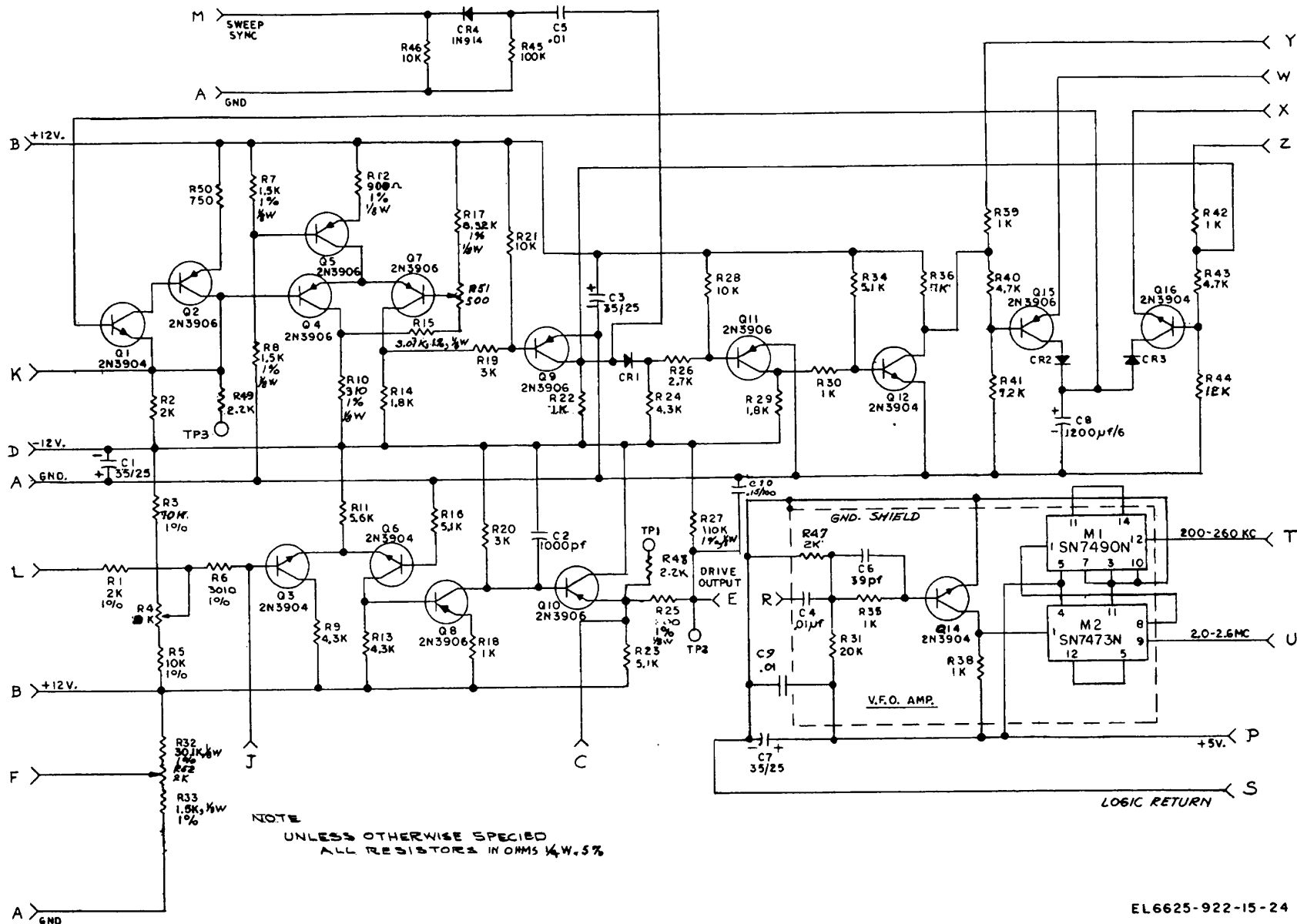
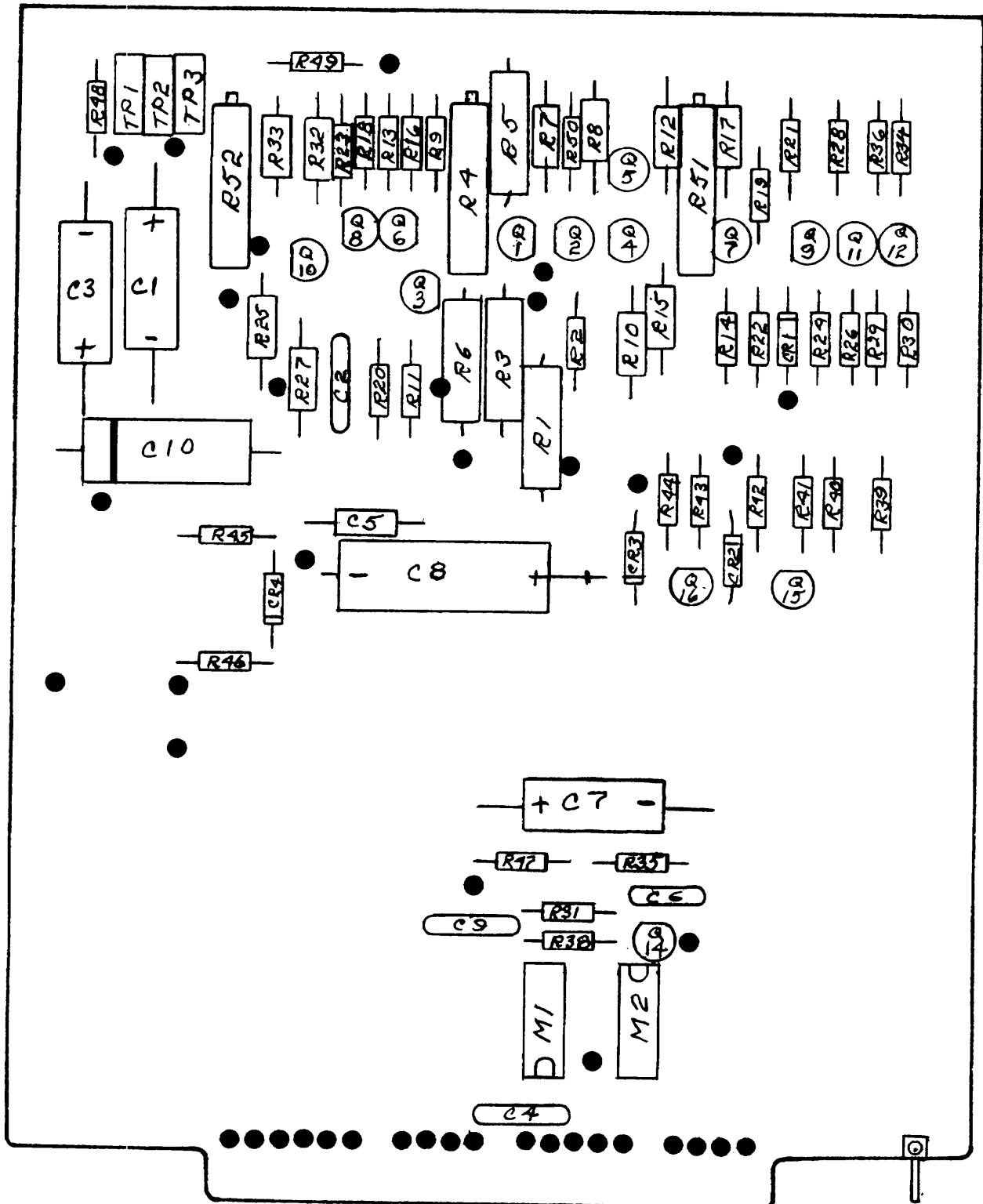

Figure 9-7. Sweep drive (A16), C-4707, schematic diagram.



EL 6625-922-15-25

Figure 9-8. Sweep drive (A16), C-4707, location of components.



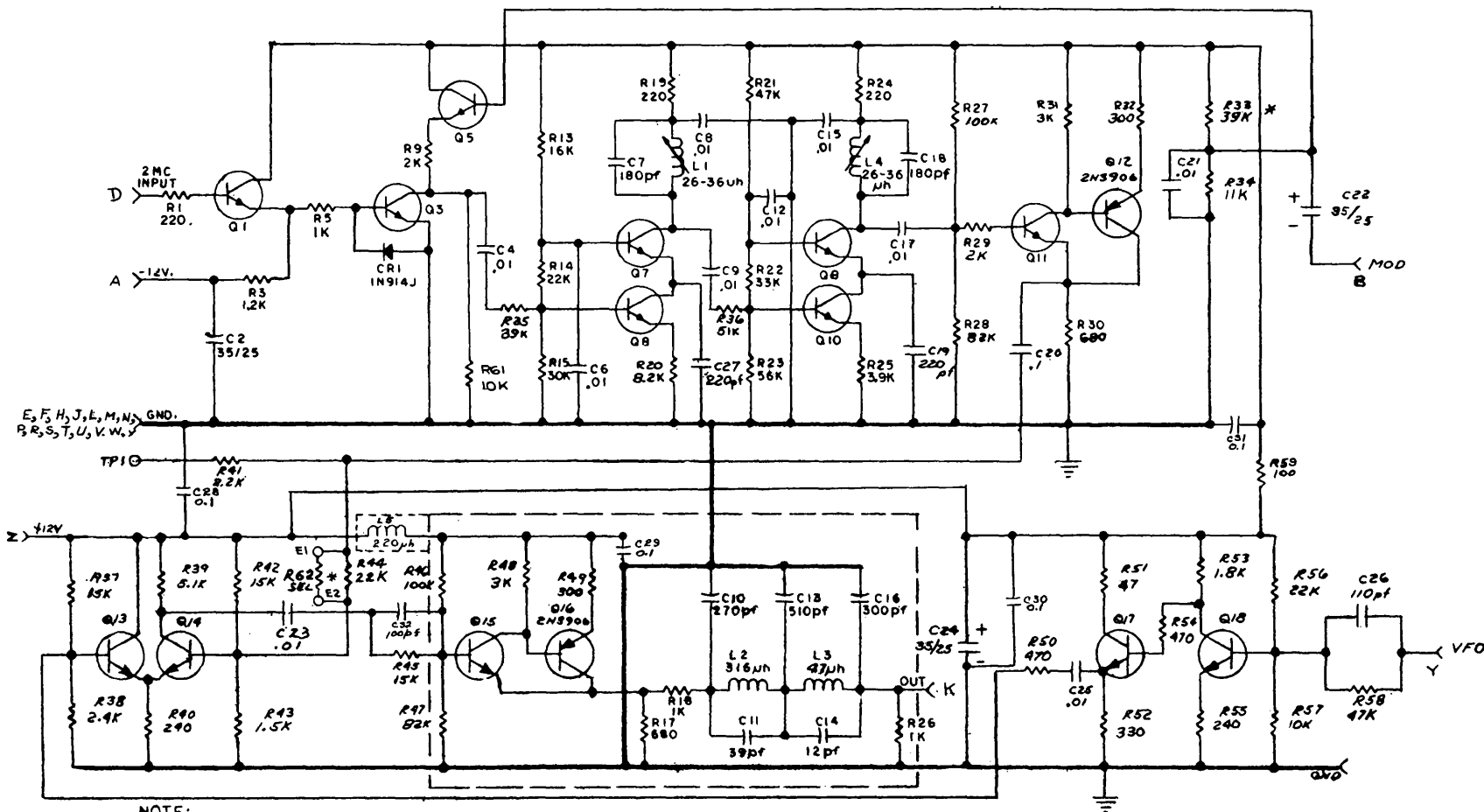

**NOTE:**  
 UNLESS OTHERWISE SPECIFIED:  
 ALL TRANSISTORS ARE 2N3904, EXCEPT Q3-2N918  
 ALL RESISTORS ARE 1/4W, ±5%  
 \* FACTORY SELECT.

EL6625-922-15-26

Figure 9-9. 2-MHz modulator mixer (A14), C-4705, schematic diagram.

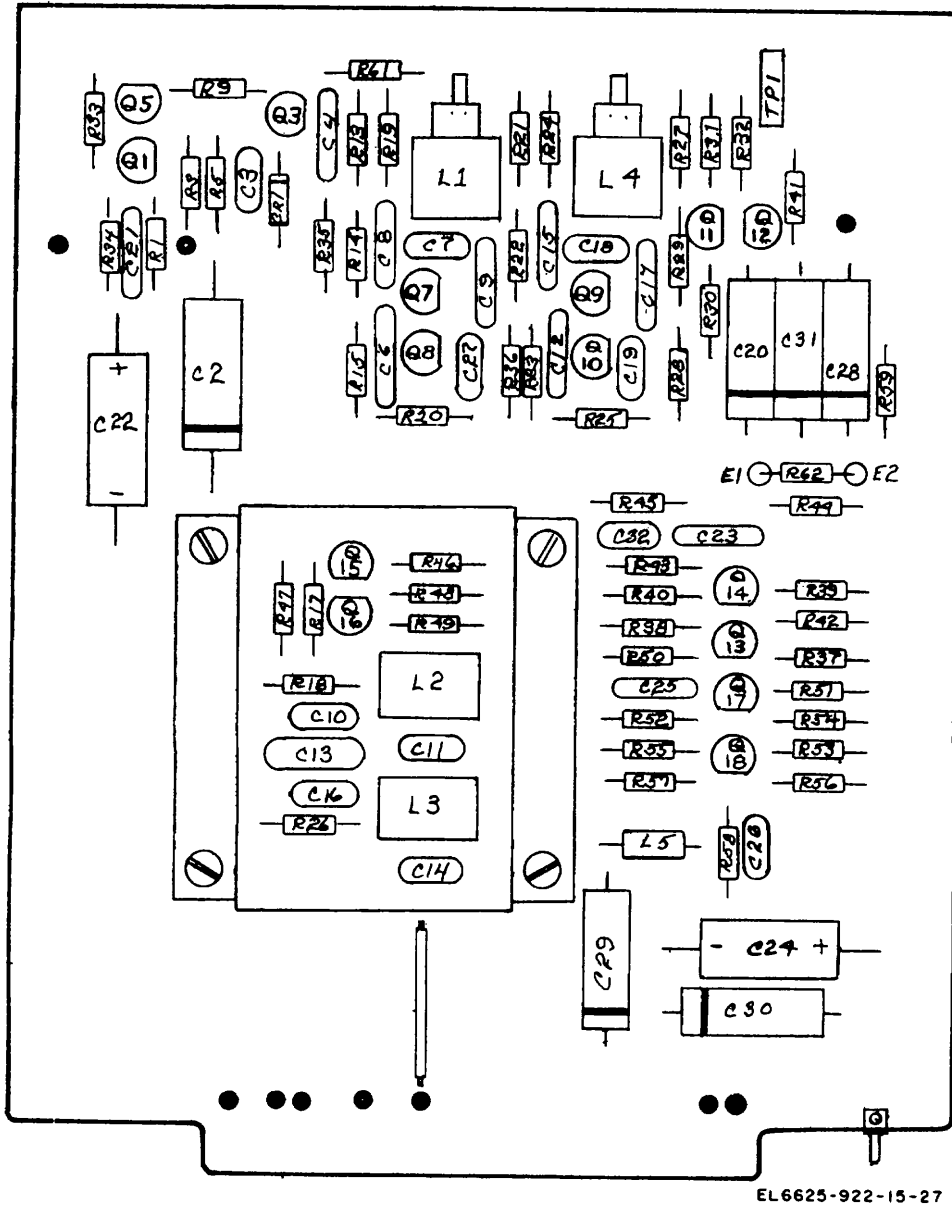

Figure 9-10. 2-MHz modulator mixer (A14), C-4705, location of component.

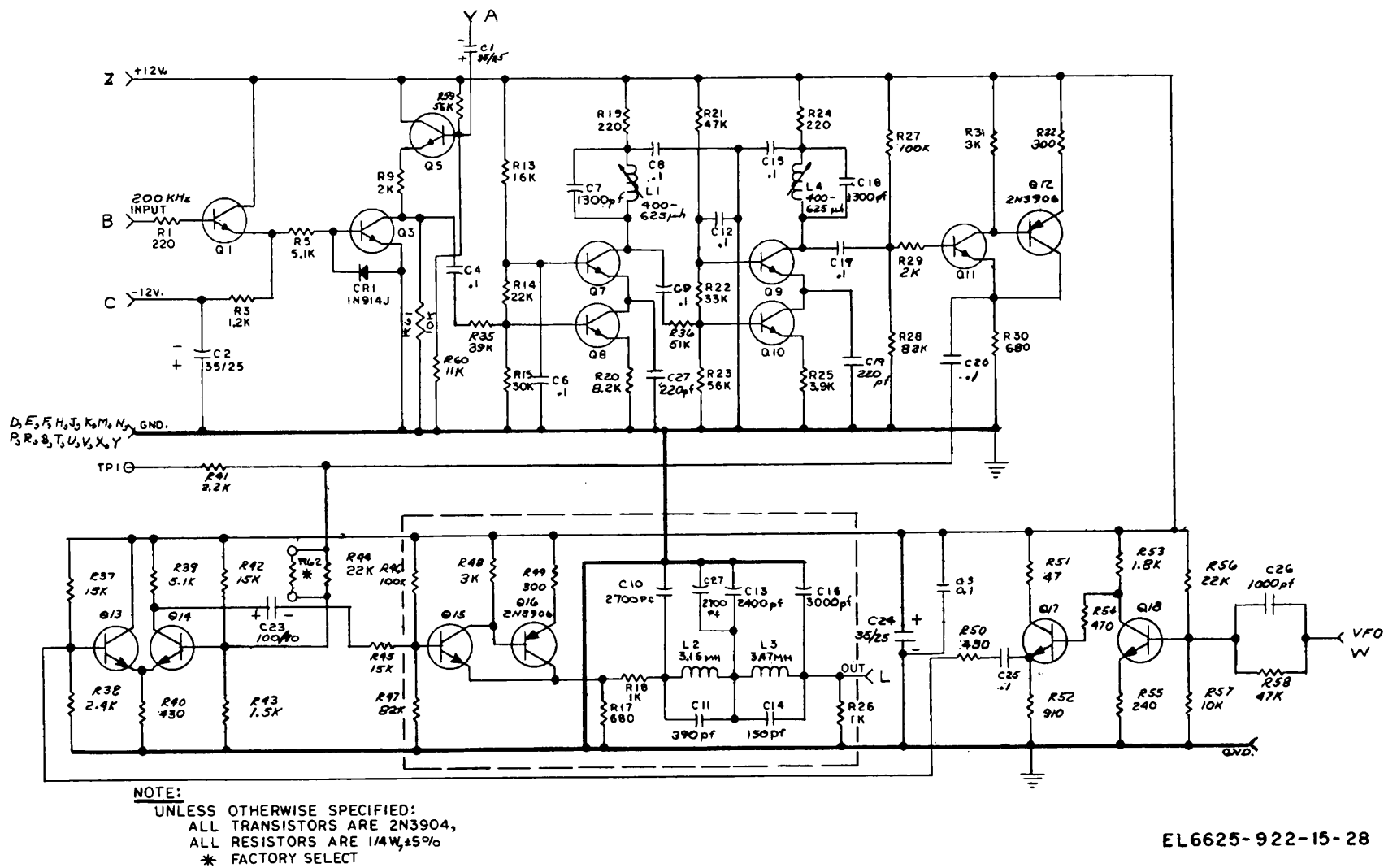
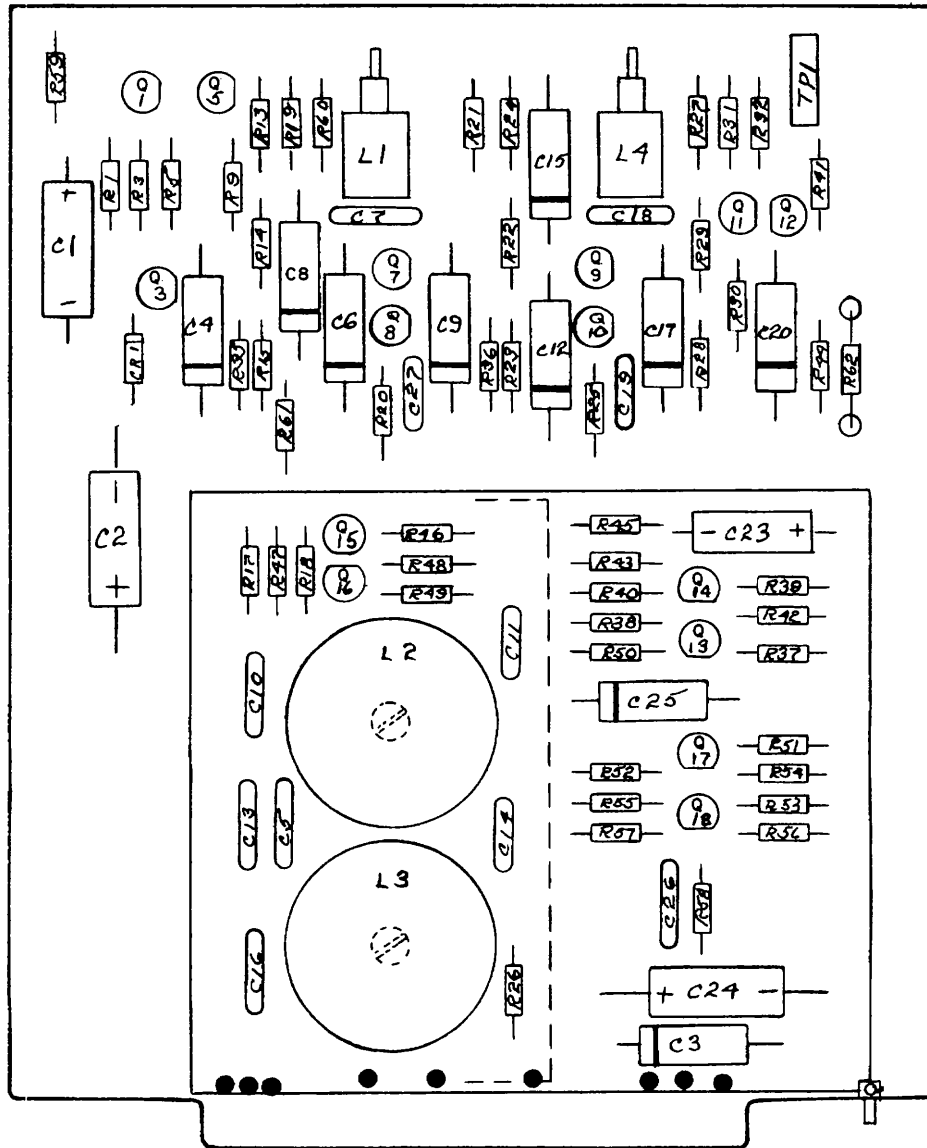
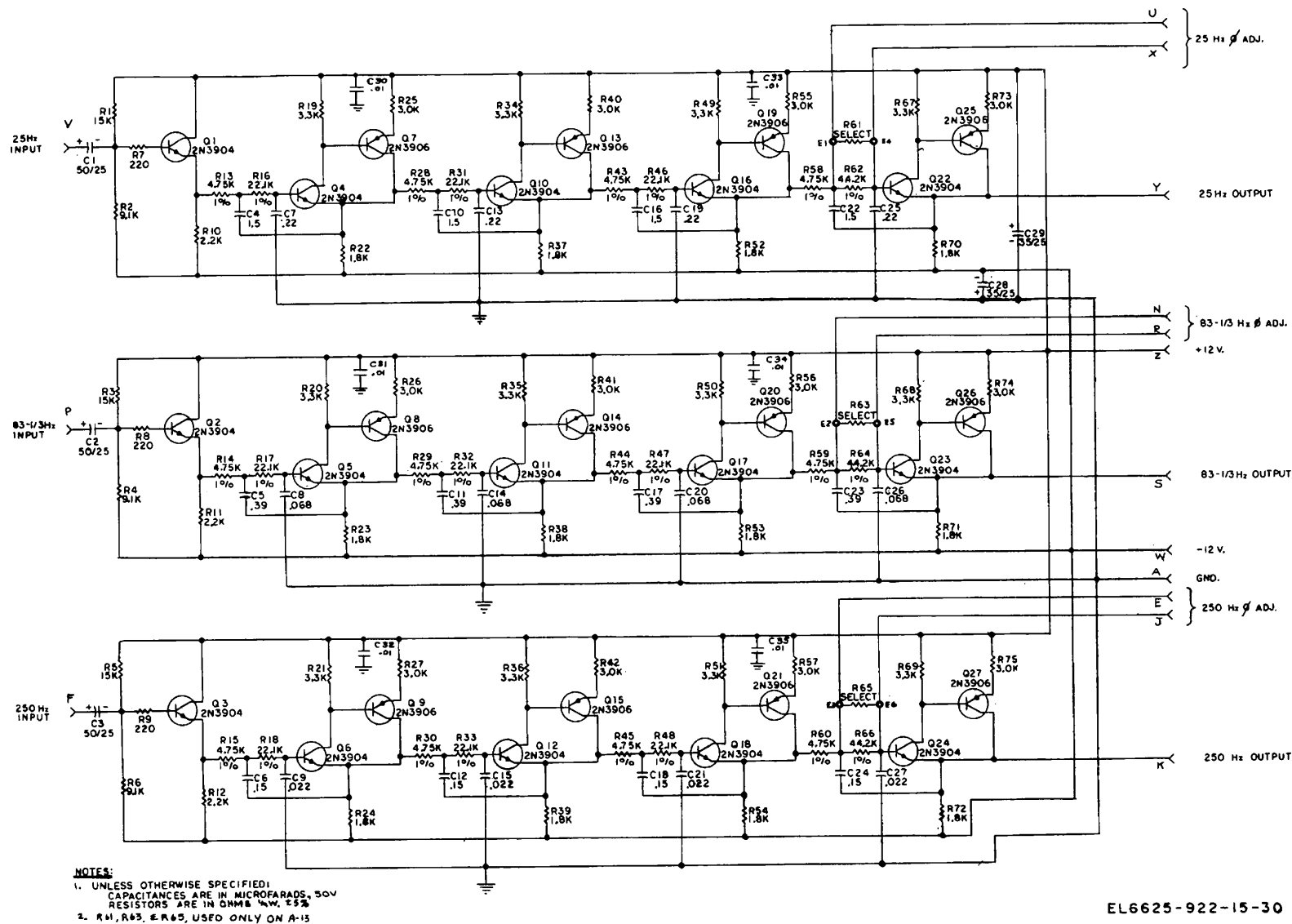

Figure 9-11. 200-kHz modulator mixer (A15), C-4706, schematic diagram.



EL6625-922-15-29

Figure 9-12. 200-kHz modulator mixer (A15), C-4706, location of components.



EL6625-922-15-30

Figure 9-13. Low-pass active filters (A7, A13), C-4699-1, C-4699-2, schematic diagram.

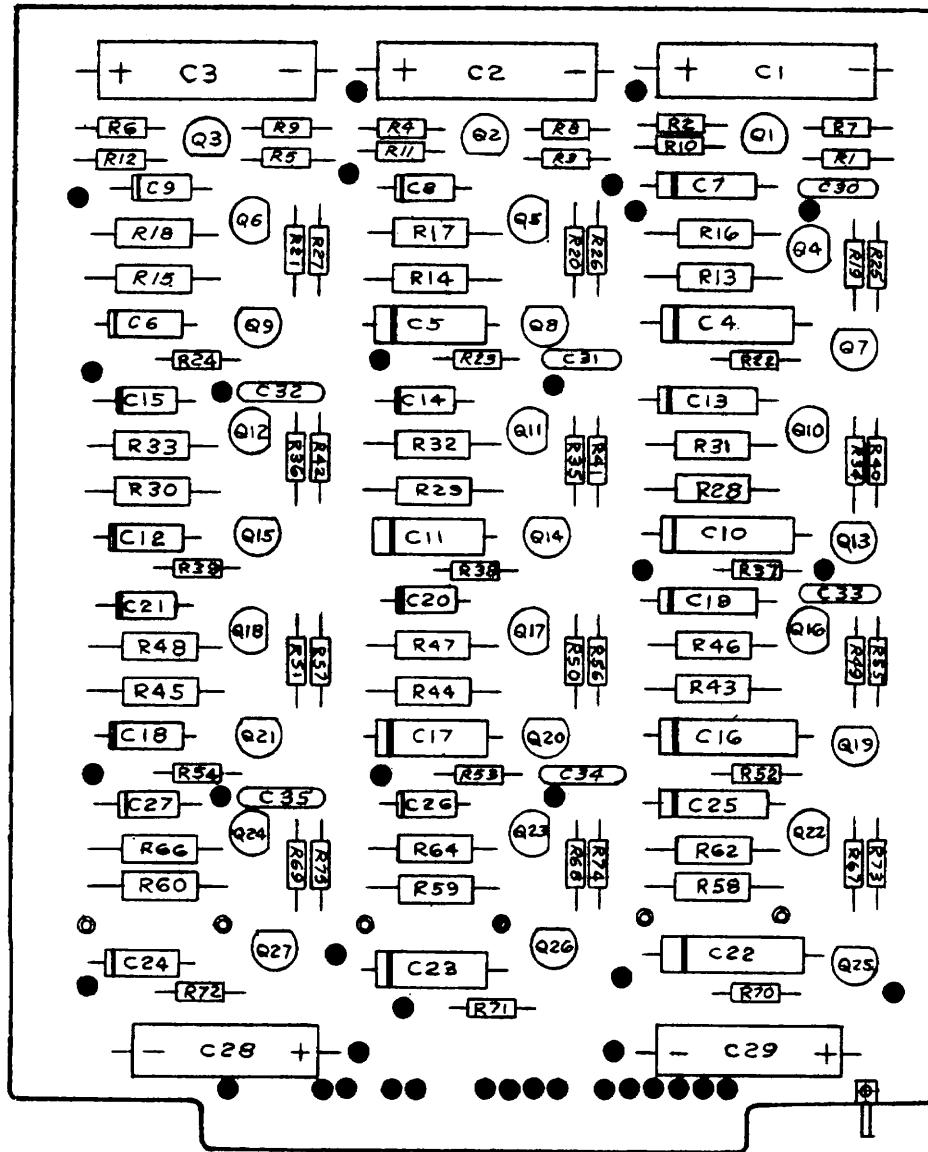

EL 6625-922-15-31

Figure 9-14. Low-pass active filters (A7), C-4699-1, location of components.

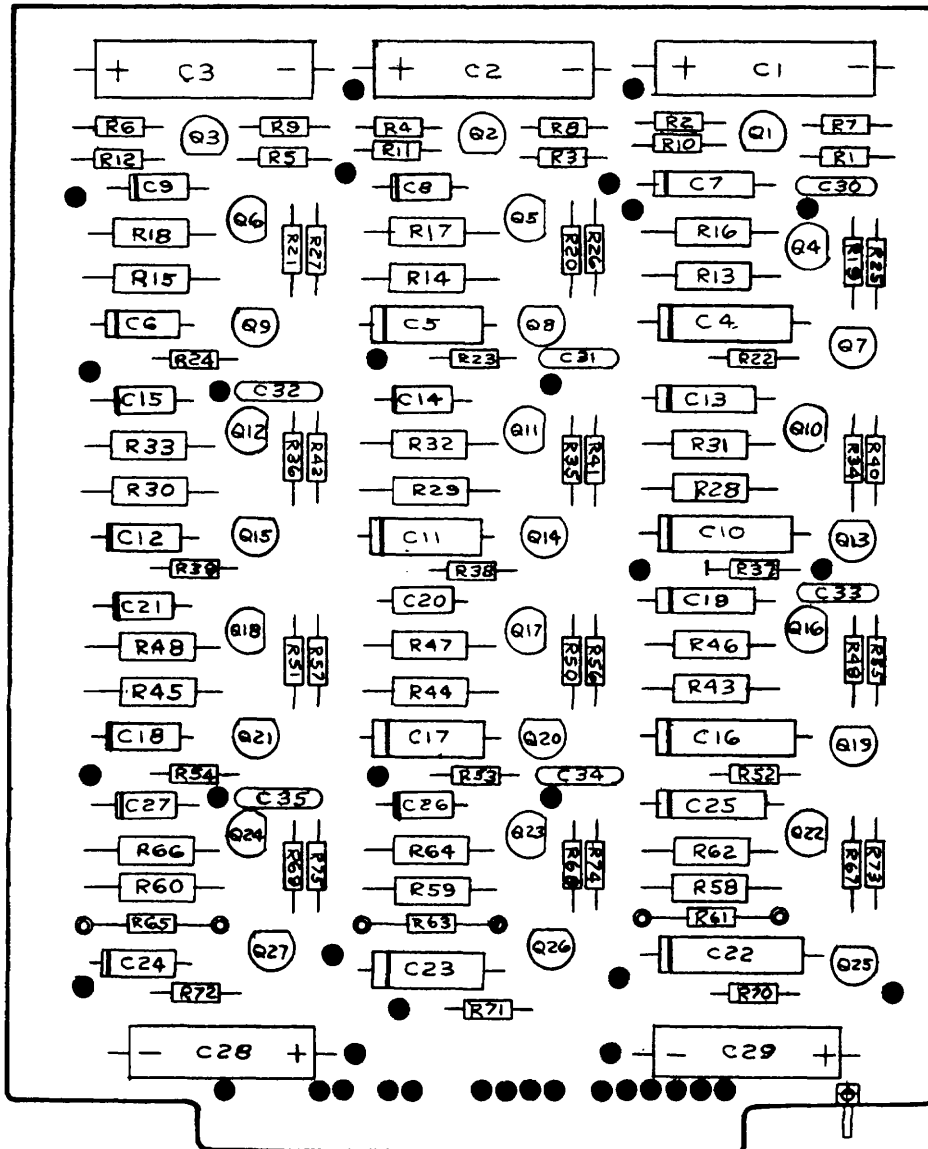

EL6625-922-15-32

Figure 9-15. Lowpass active filter (A13), C-4699-2, location of components.

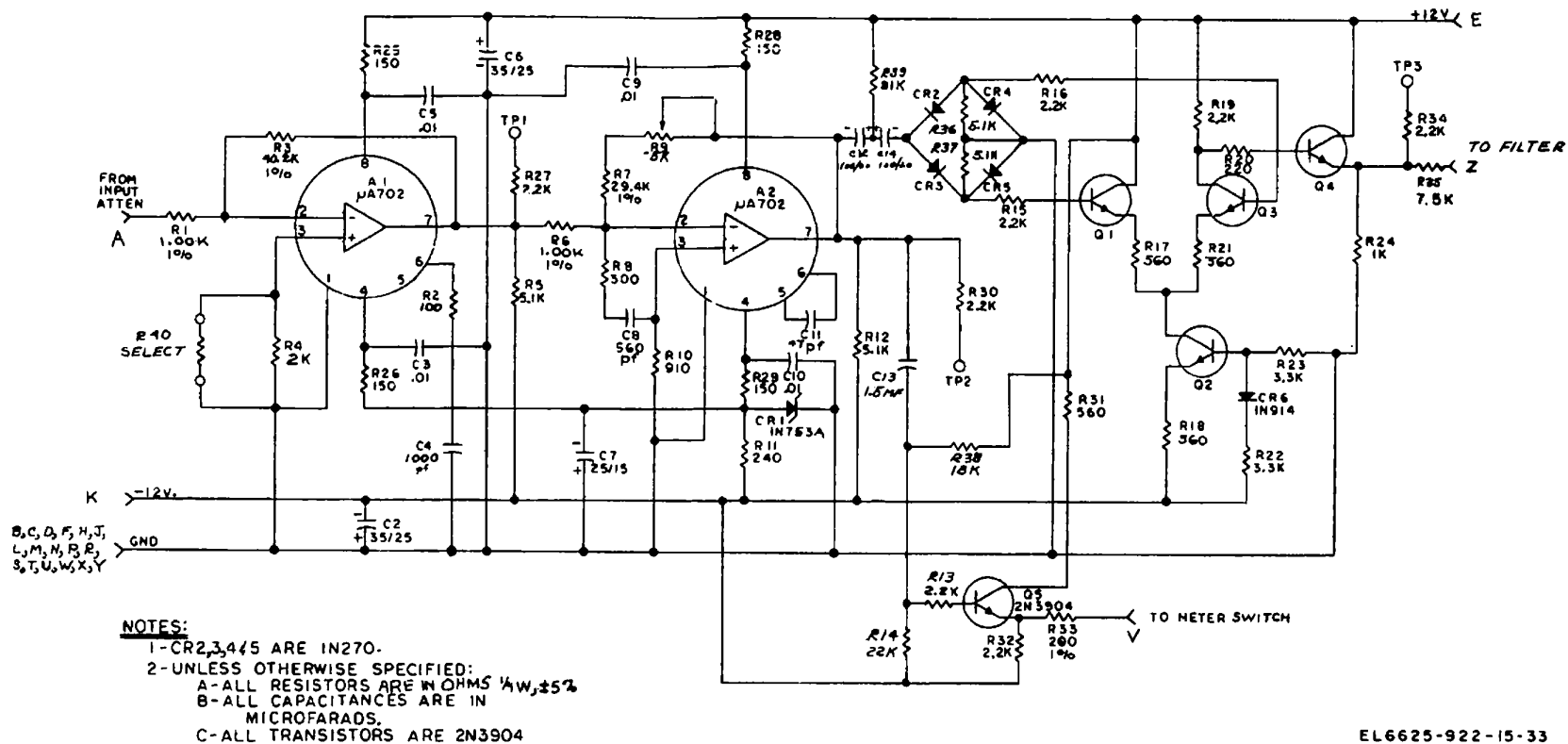

EL 6625-922-15-33

Figure 9-16. Input amplifier and demodulator (A6), C-4698, schematic diagram.



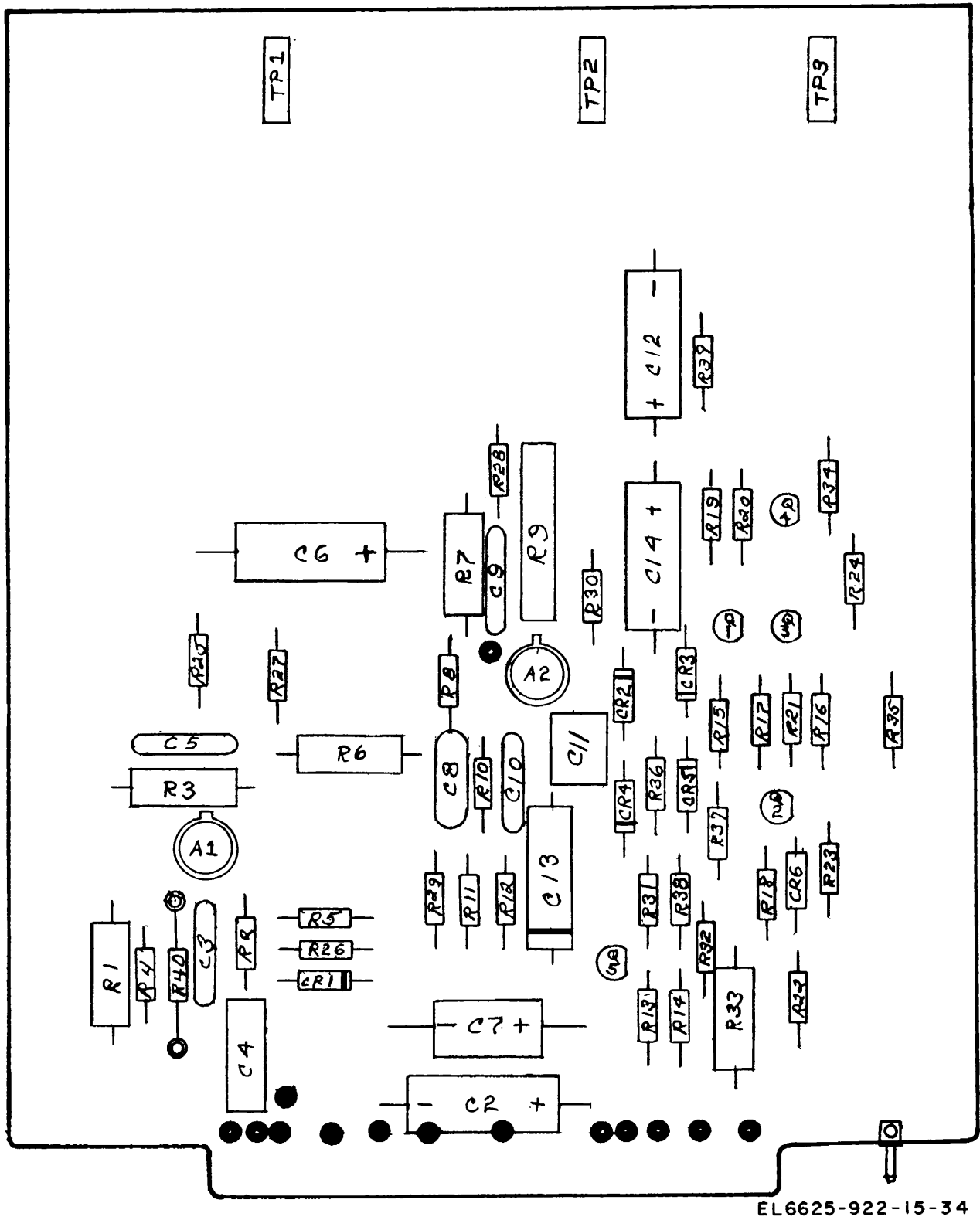

EL6625-922-15-34

Figure 9-17. Input amplifier and demodulator (A6), C-4698, location of components.

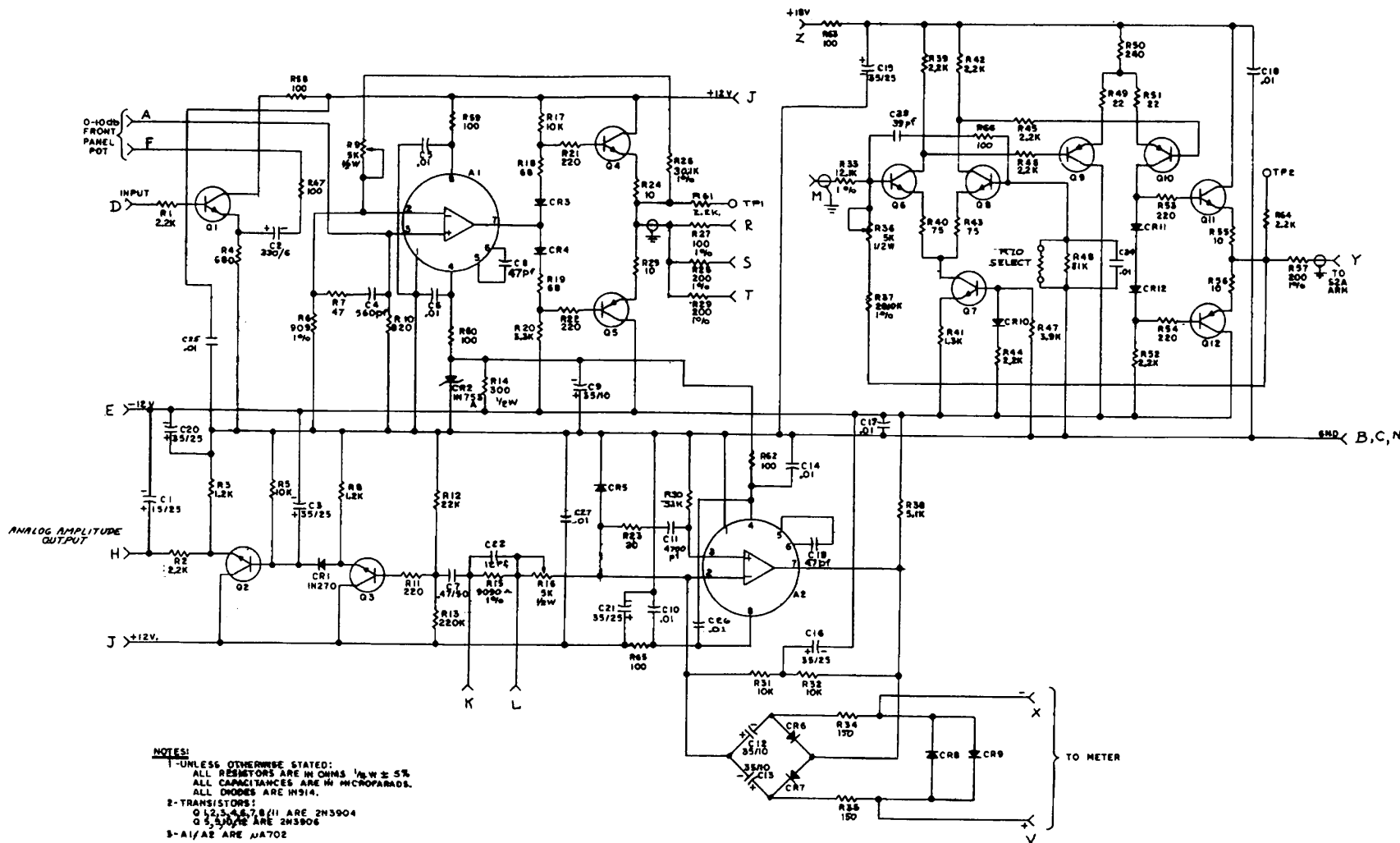

EL6625-922-15-35

Figure 9-18. Output amplifier and meter amplifier (A12), C-4704, schematic diagram.

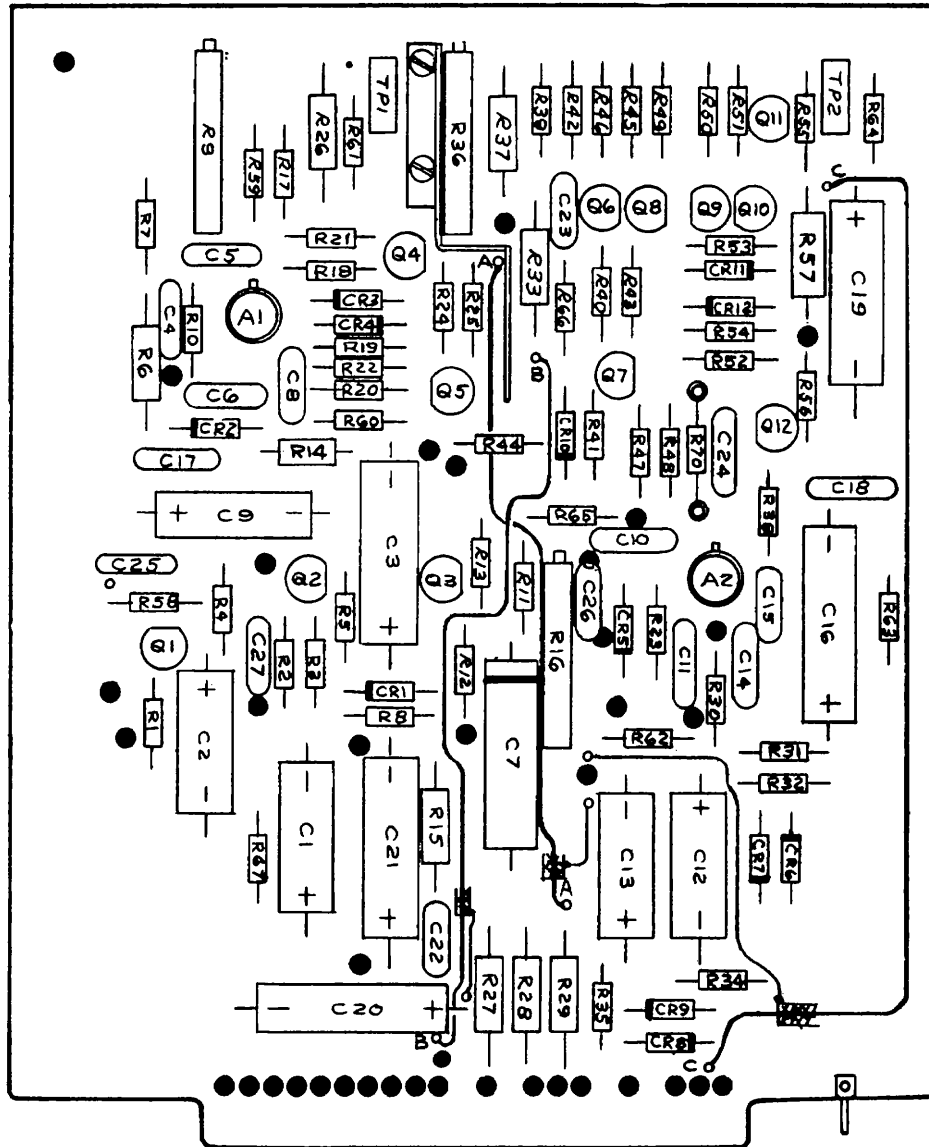

EL 6625-922-15-36

Figure 9-19. Output amplifier and meter amplifier (A12), C-4704, location of components.

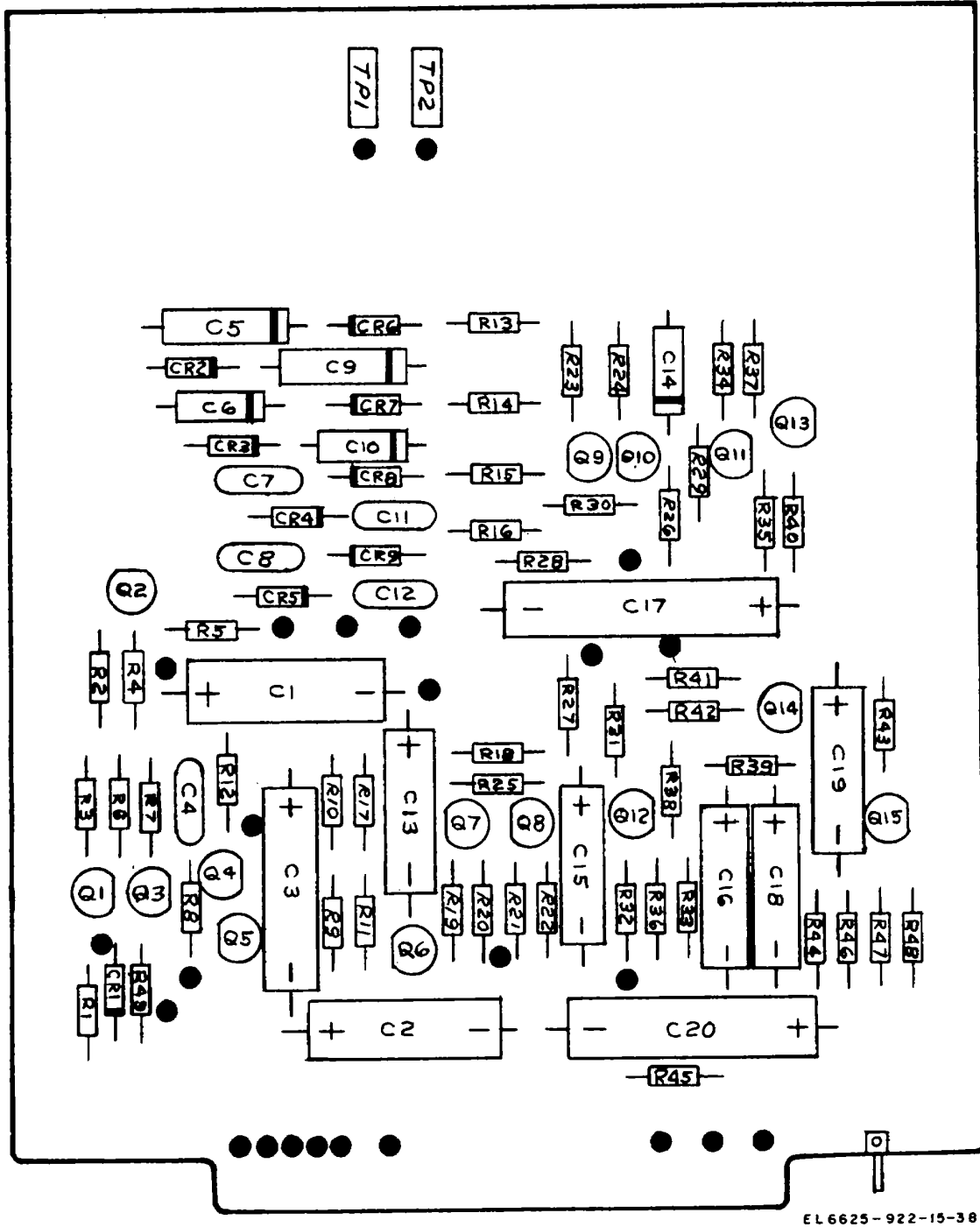

Figure 9-21. Analog output (A3), C-4801, location of components.

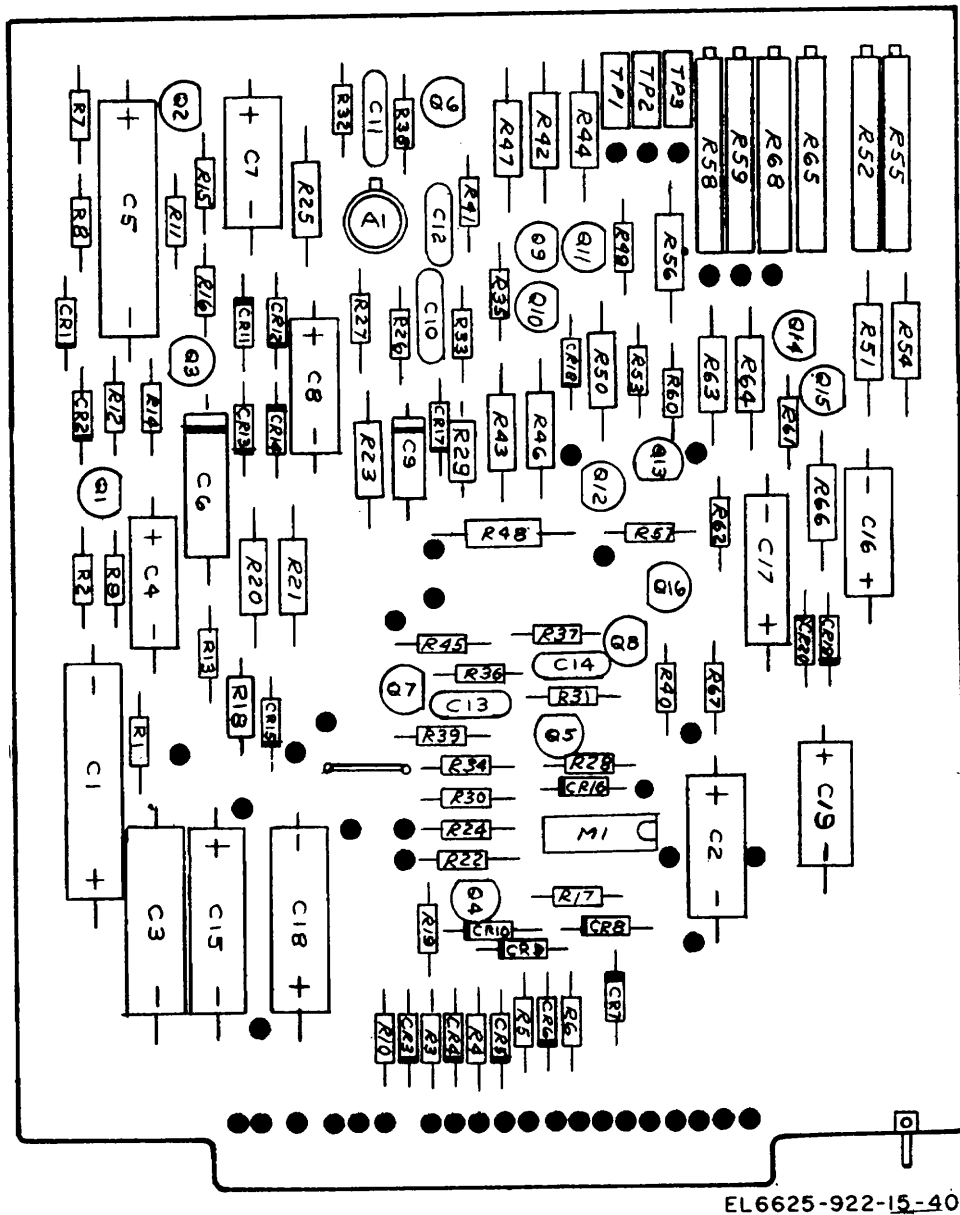
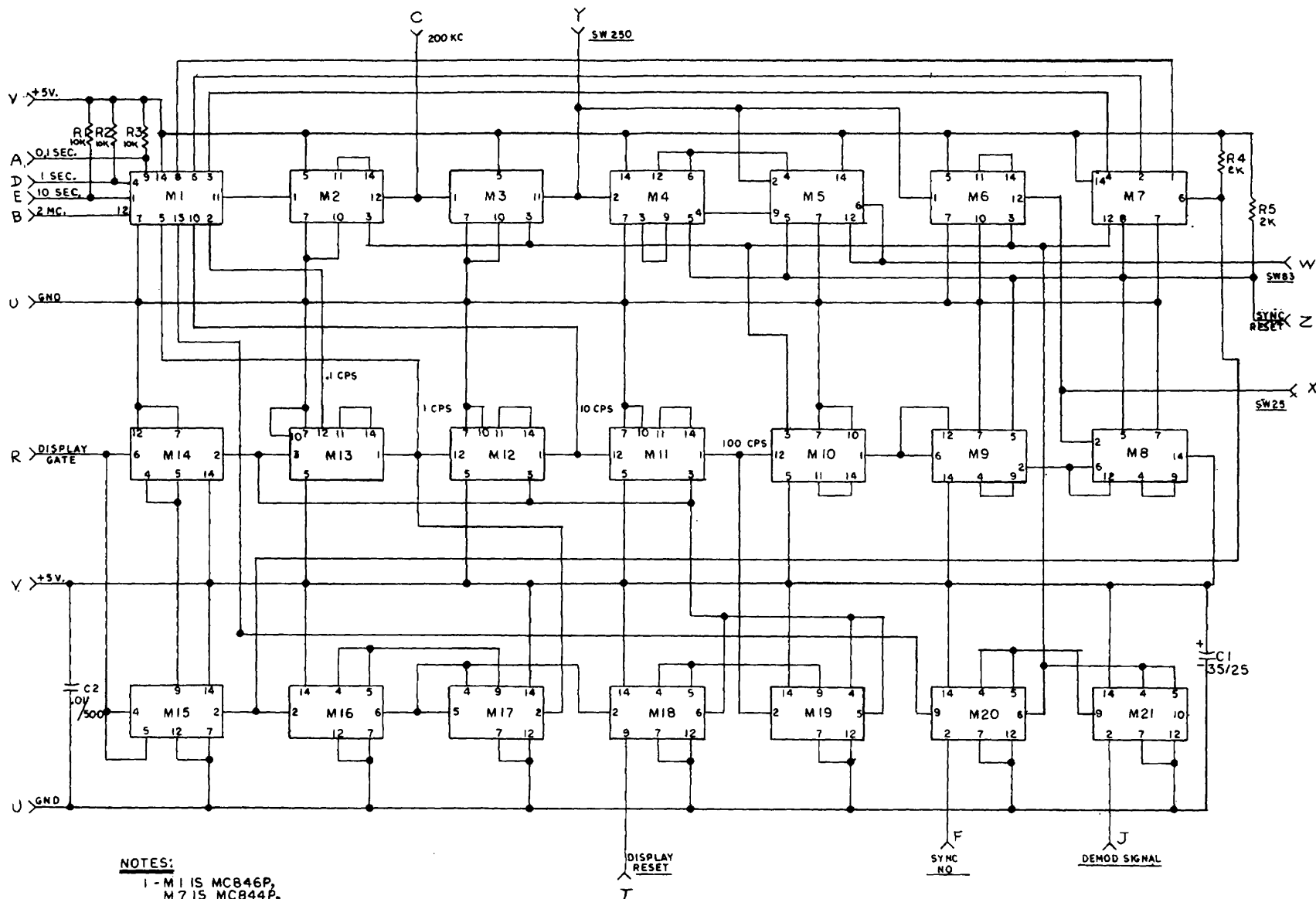

Figure 9-23. Delay output (A8), C-4700, location of components.



**NOTES:**  
 1 - M1 IS MCB46P,  
 M7 IS MCB44P,  
 M2,3,6,10 THRU 13 ARE SN7490N,  
 M4,5,8,9,14 THRU 21 ARE MCB45P.  
 2 - R1,2,3 ARE 10K, 1/4W, ±5%  
 R4,5 ARE 2K, 1/4W, ±5%

EL6625-922-15-41

Figure 9-24. Countdown logic (A10), C-4702, schematic diagram.

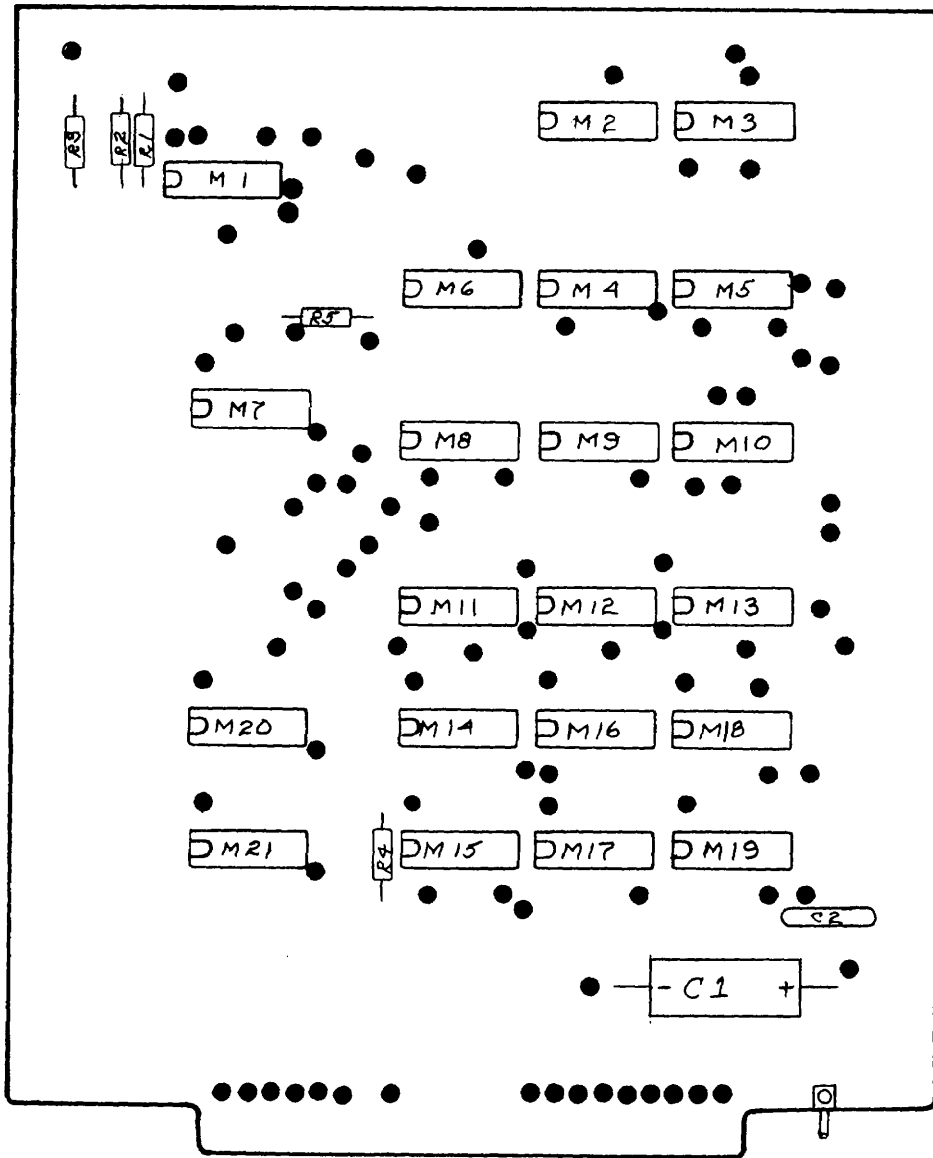

EL6625-922-15-42

Figure 9-25. Countdown logic (A10), C-4702, location of components.

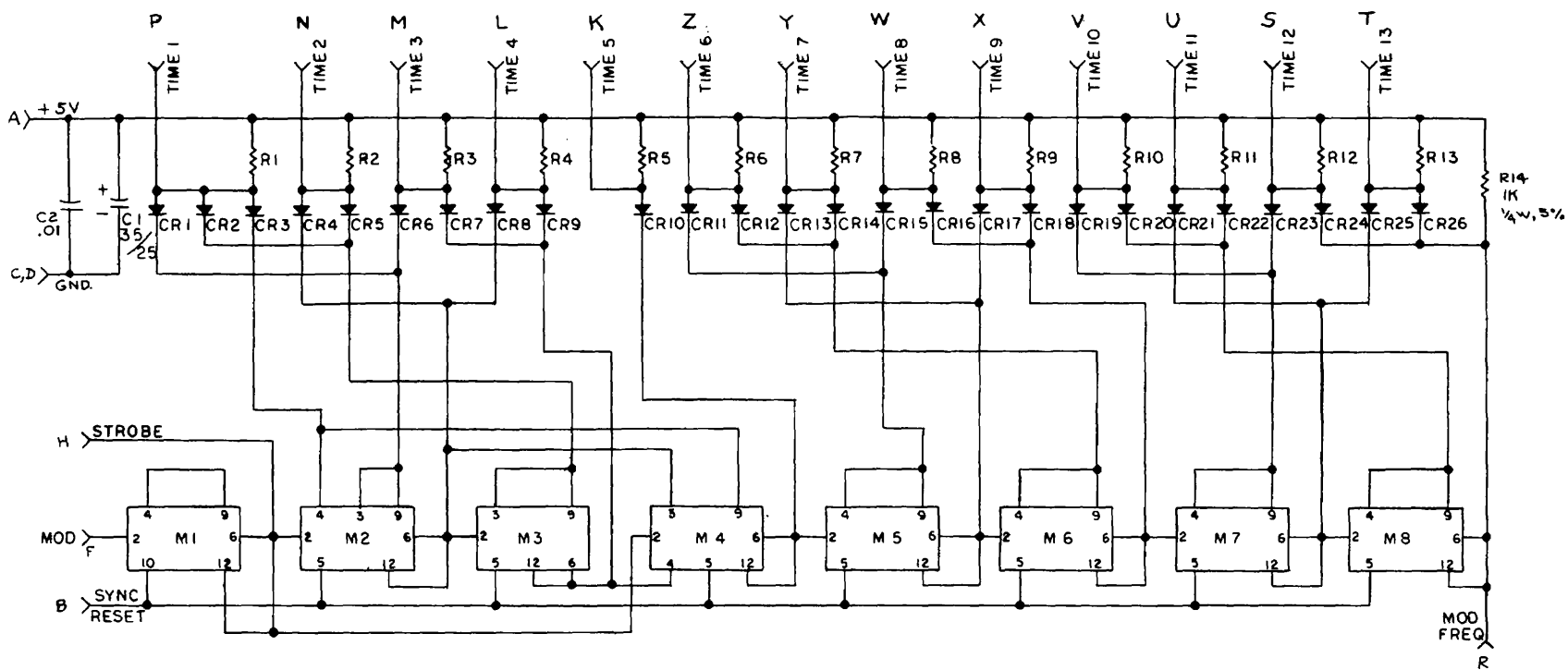

**NOTES:**

- 1- R1 THRU R13 ARE 20K, 1/4W, ±5%.
- 2- CR1 THRU CR26 ARE 1N914.
- 3- M1 THRU M8 ARE MC845P.

EL 6625-922-15-43

Figure 9-26. Time delay logic (A9), C-4701, schematic diagram.



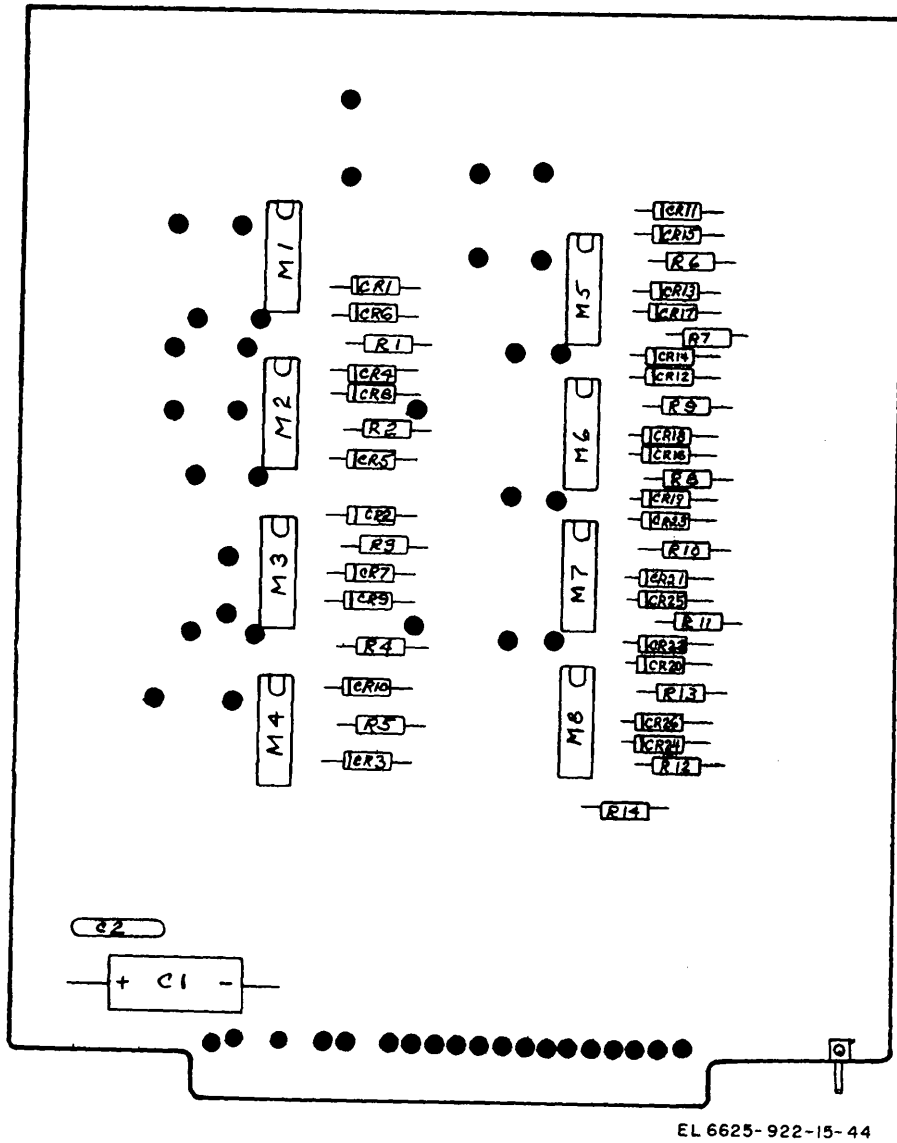
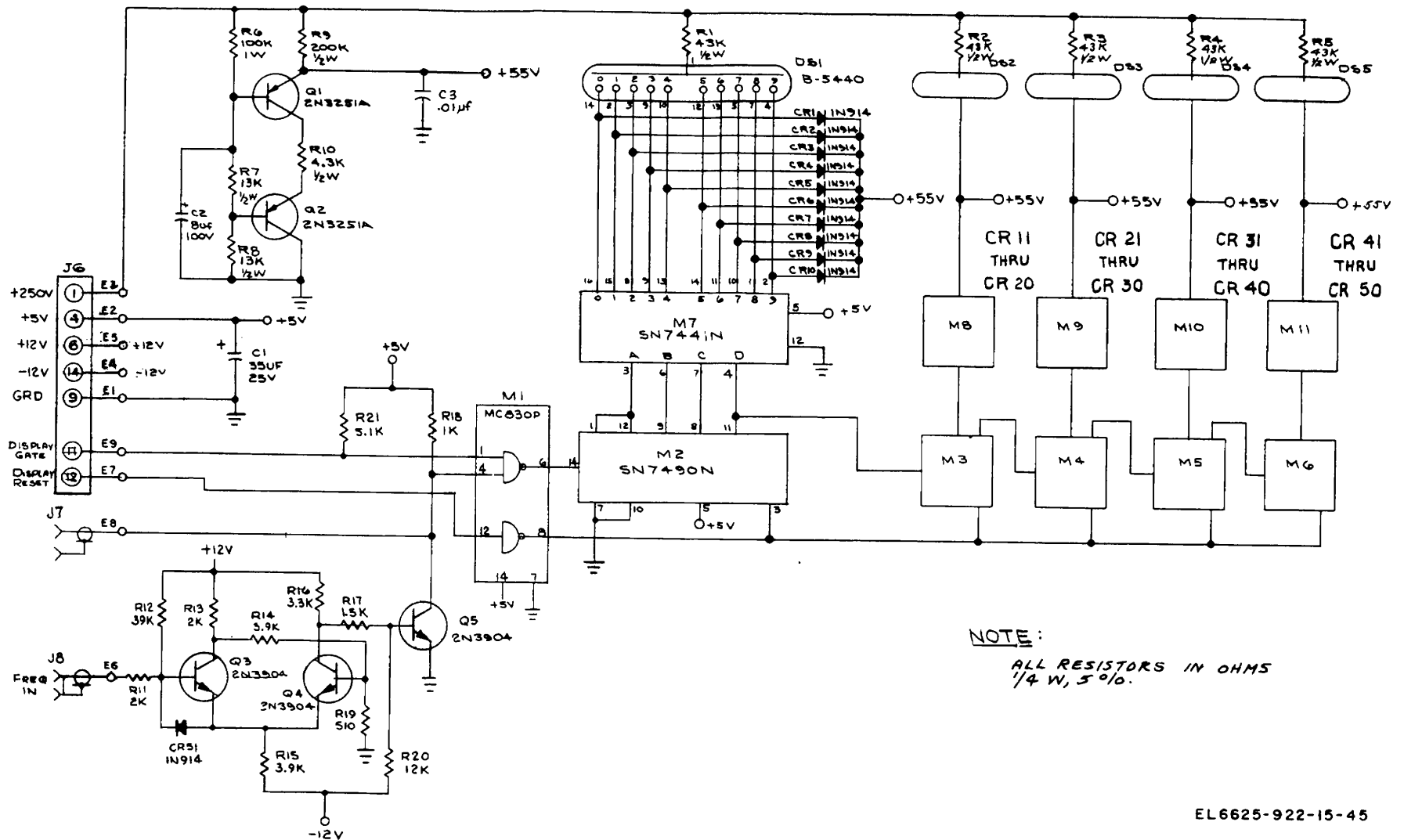
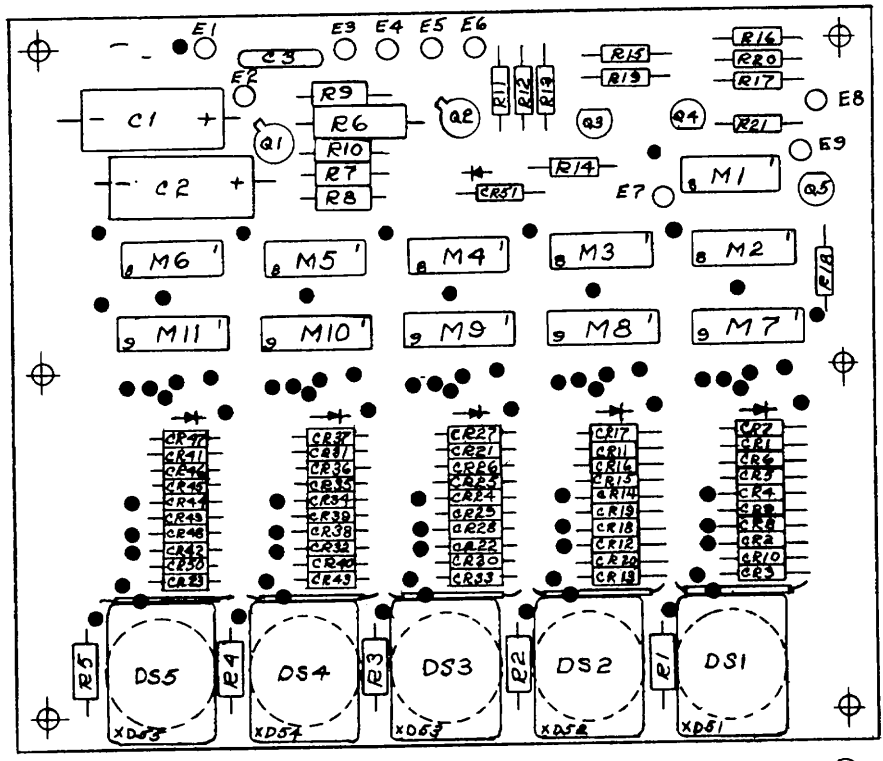

Figure 9-27. Time delay logic (A9), C-4701, location of components.



EL6625-922-15-45

Figure 9-28. Frequency counter/display (A1), D-4637, schematic diagram.



EL 6625-922-15-46 (1)

Figure 9-29(1). Frequency counter/display (A1), D-4637, location of components (part 1 of 2).

WIRE CHART		
DES. NO.	COLOR	WIRE TYPE
0	BLACK	#22 STRD.
1	BROWN	#22 STRD.
2	RED	#22 STRD.
3	ORANGE	#22 STRD.
4	YELLOW	#22 STRD.
5	GREEN	#22 STRD.
6	BLUE	#22 STRD.
7	VIOLET	#22 STRD.
9	WHITE	RG-100/U

LEFT SIDE VIEW

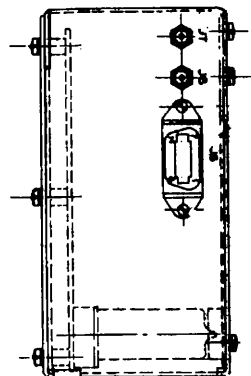

TOP VIEW

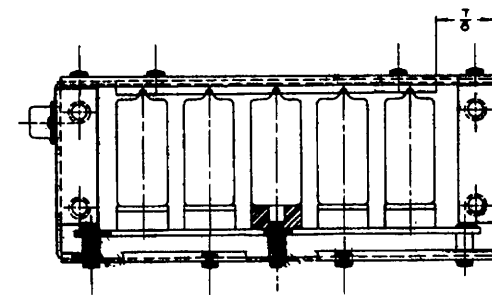
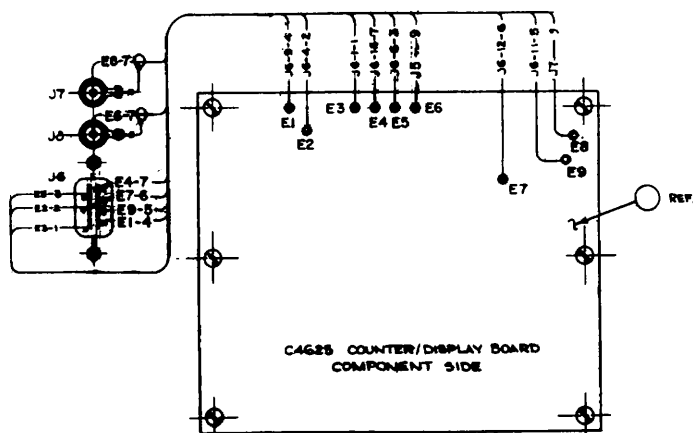
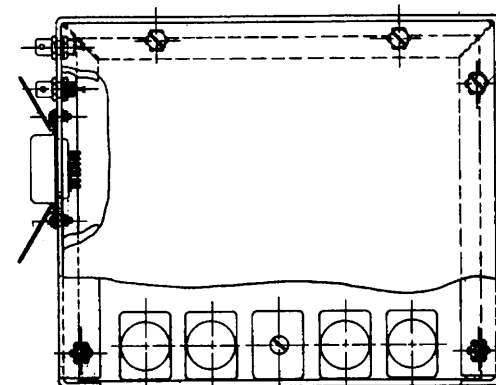

FRONT VIEW

EL6625-922-15-46 (2)

Figure 9-29 (2). Frequency counter-display (A1), D-4637, location of components (part 2 of 2).

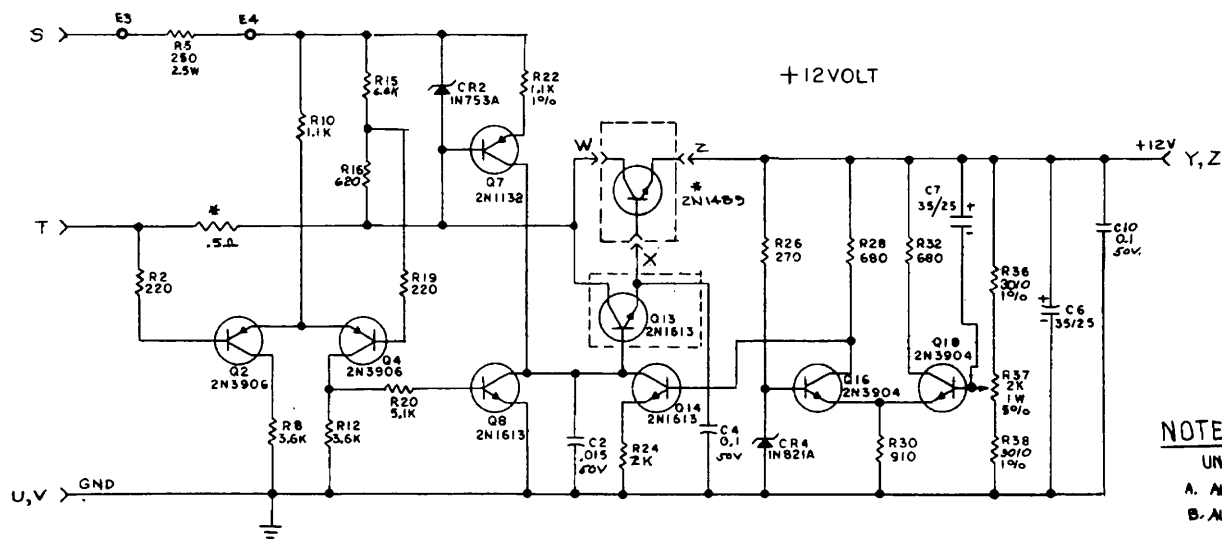
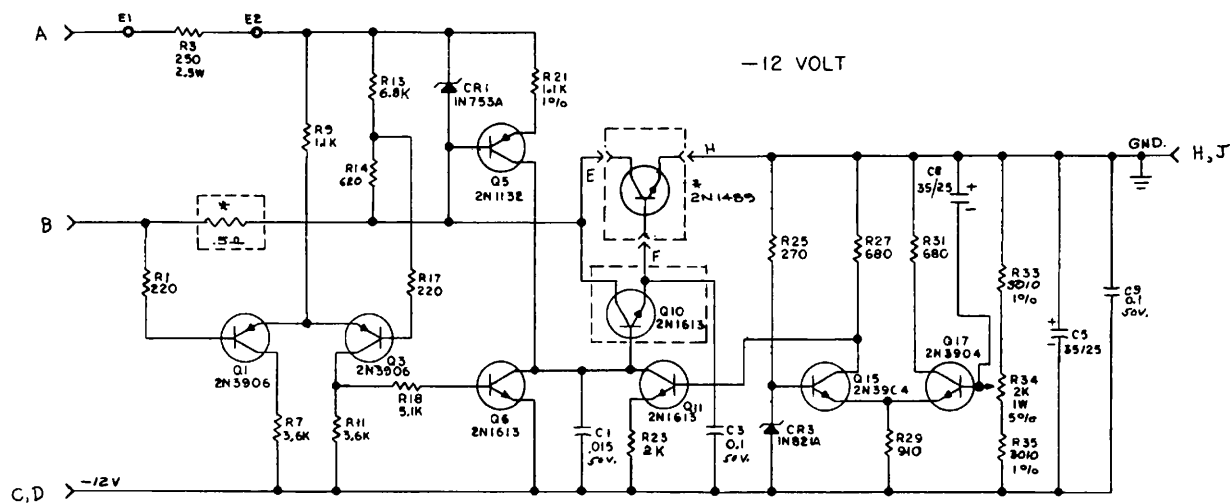

**NOTE:**  
 UNLESS OTHERWISE SPECIFIED  
 A. ALL RESISTORS ARE IN OHMS  $\frac{1}{2}\pm 5\%$   
 B. ALL CAPACITANCES IN MICROFARADS  
 EL6625-922-15-47

Figure 9-30. +12- and -12-volt regulators (A11), C-4703, schematic diagram.

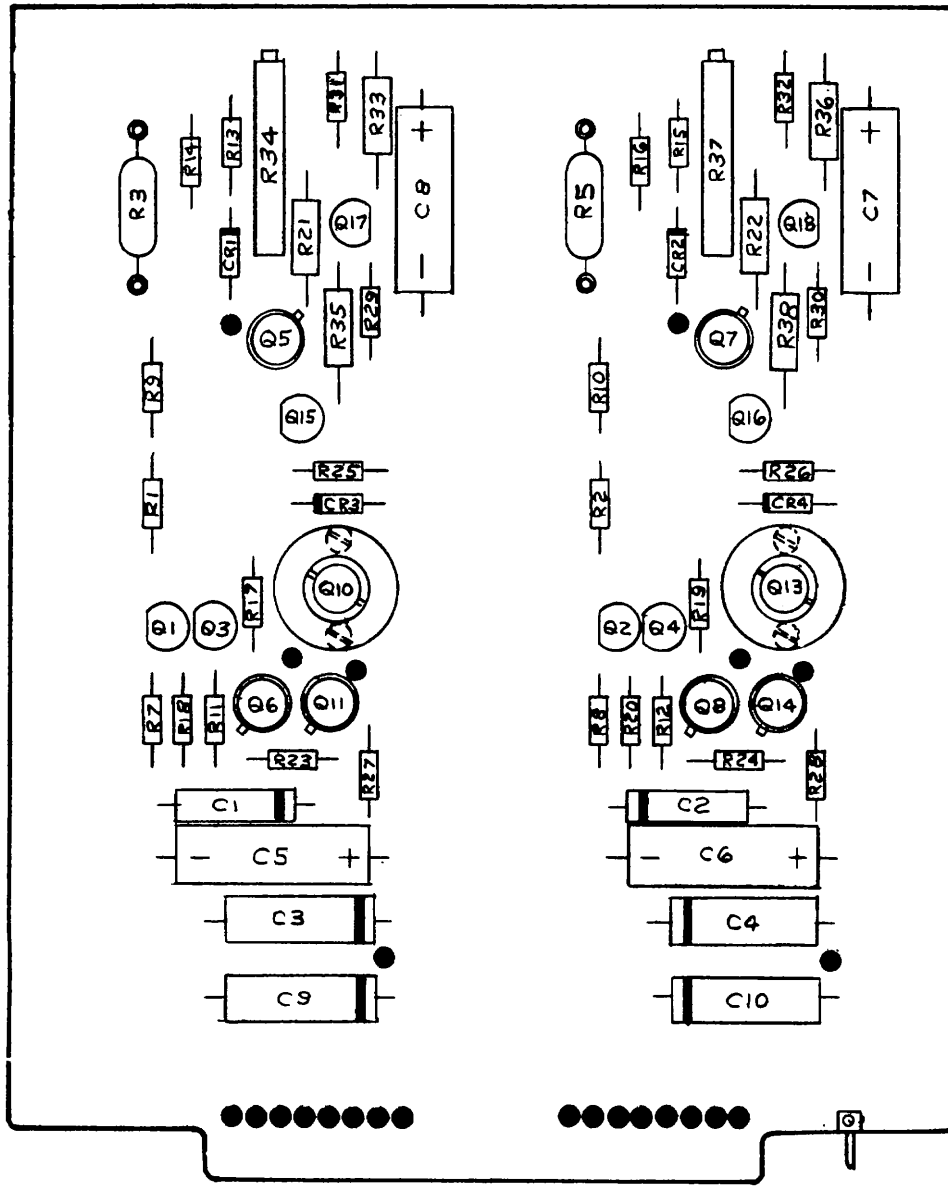

EL6625-922-15-48

Figure 9-31. +12- and -12-volt regulators (A11), C-4703, location of components.

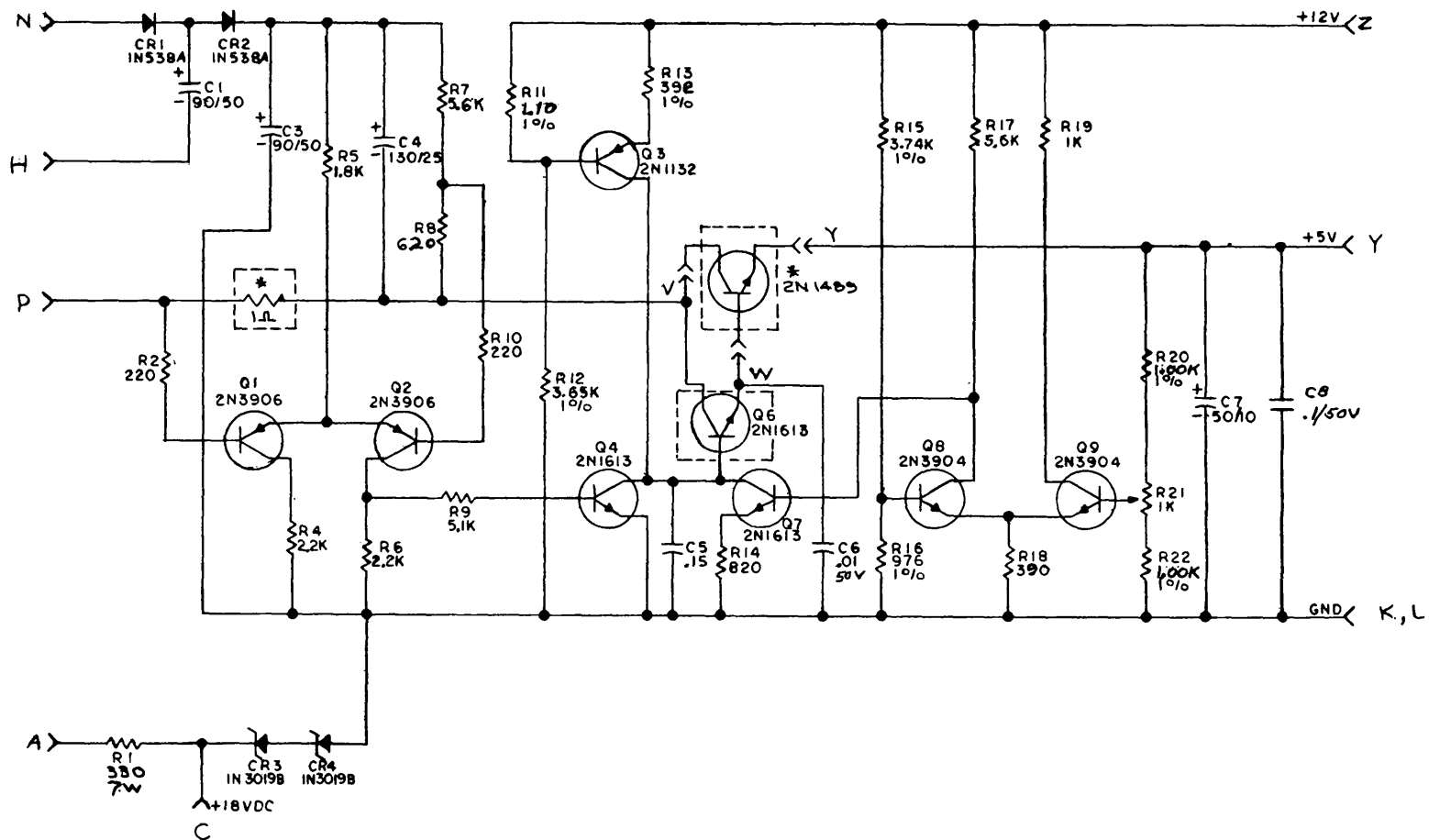

- NOTES:**
- 1- UNLESS OTHERWISE SPECIFIED:  
 ALL RESISTORS ARE IN OHMS 1/4 W, ± 5%  
 CAPACITANCES ARE IN MICROFARADS.
  - 2- FOR ASSEMBLY DWG. SEE C4697.
  - 3- \* MOUNTED ON CHASSIS

Figure 9-32. +5-volt regulator (A5), C-4697, schematic diagram.

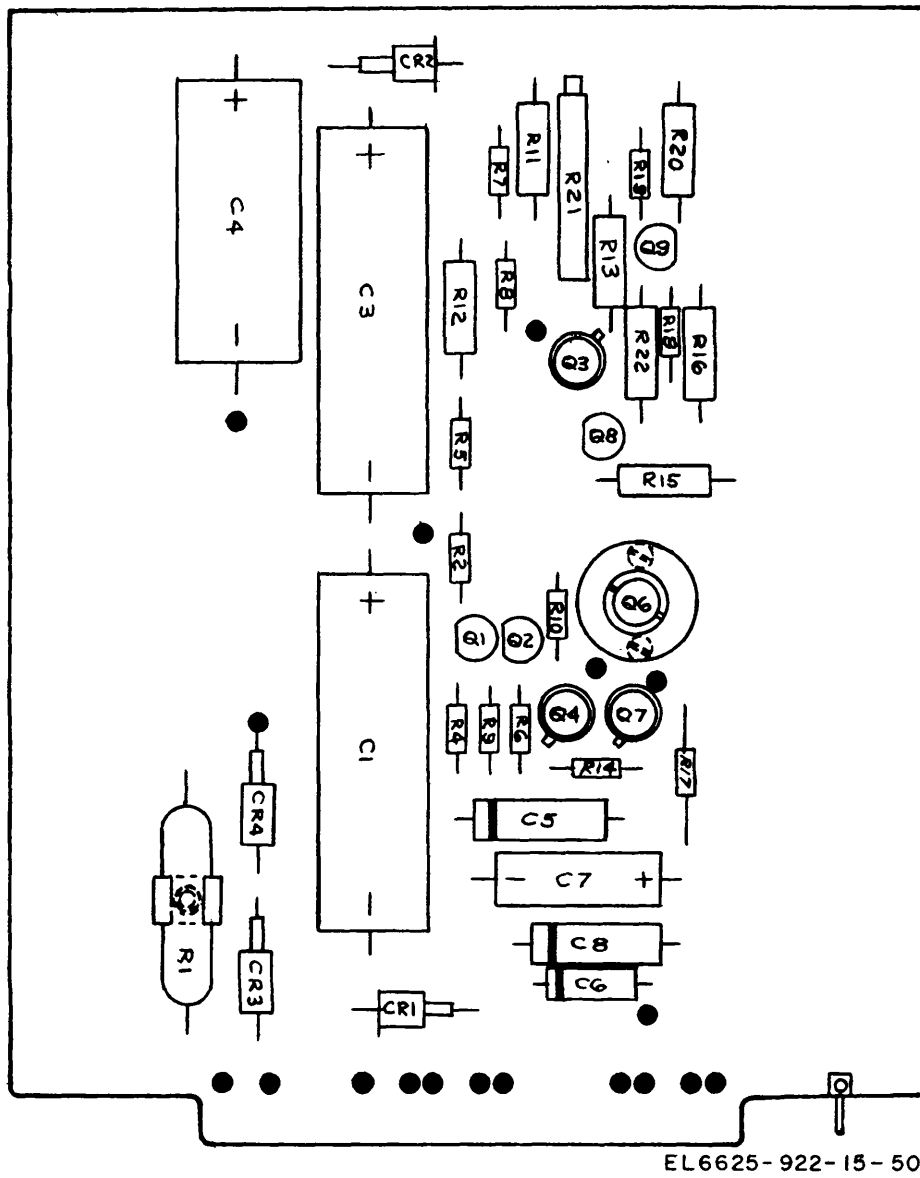

Figure 9-33. +5-volt (A5), C-4697, location of components.



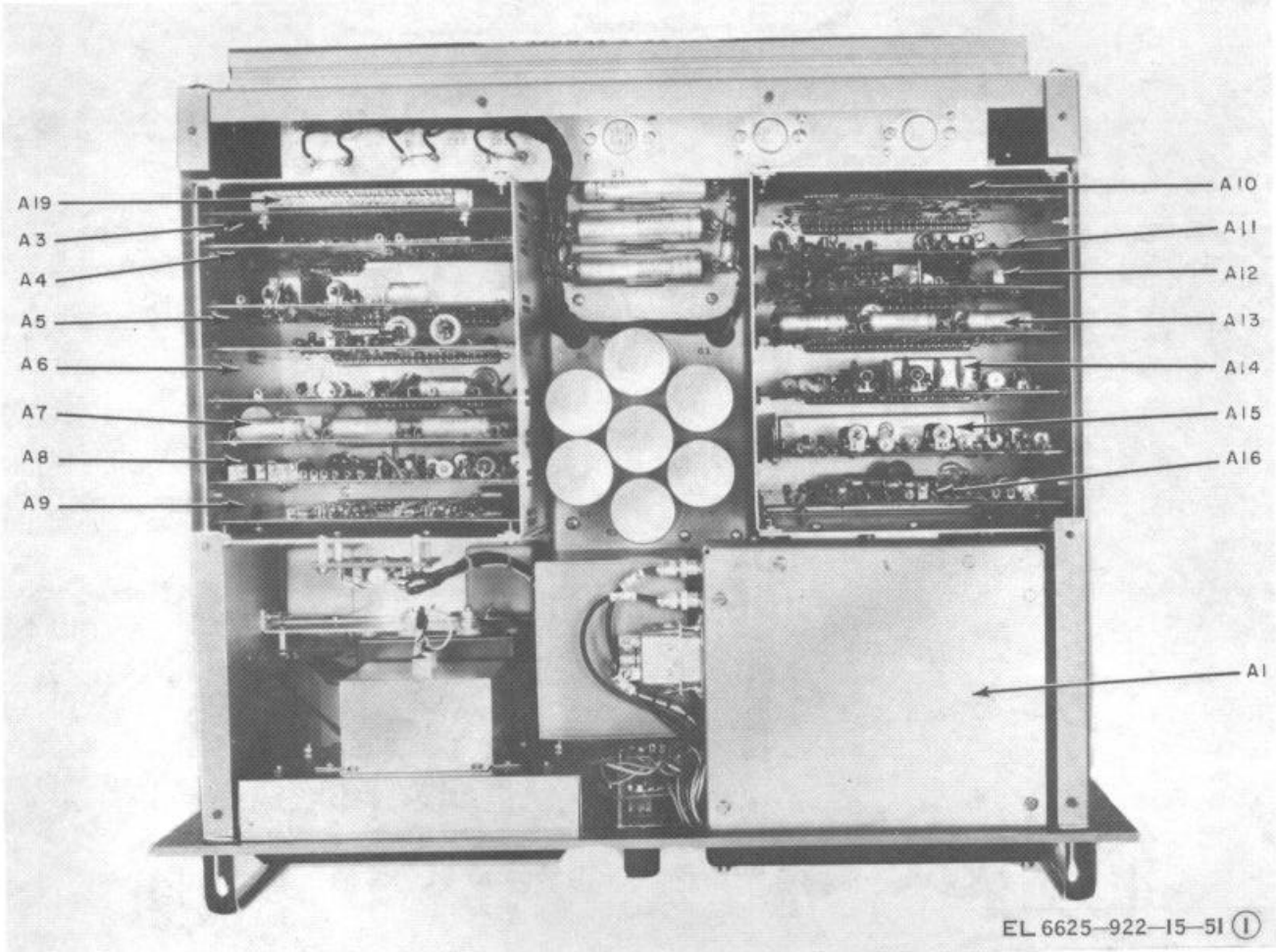
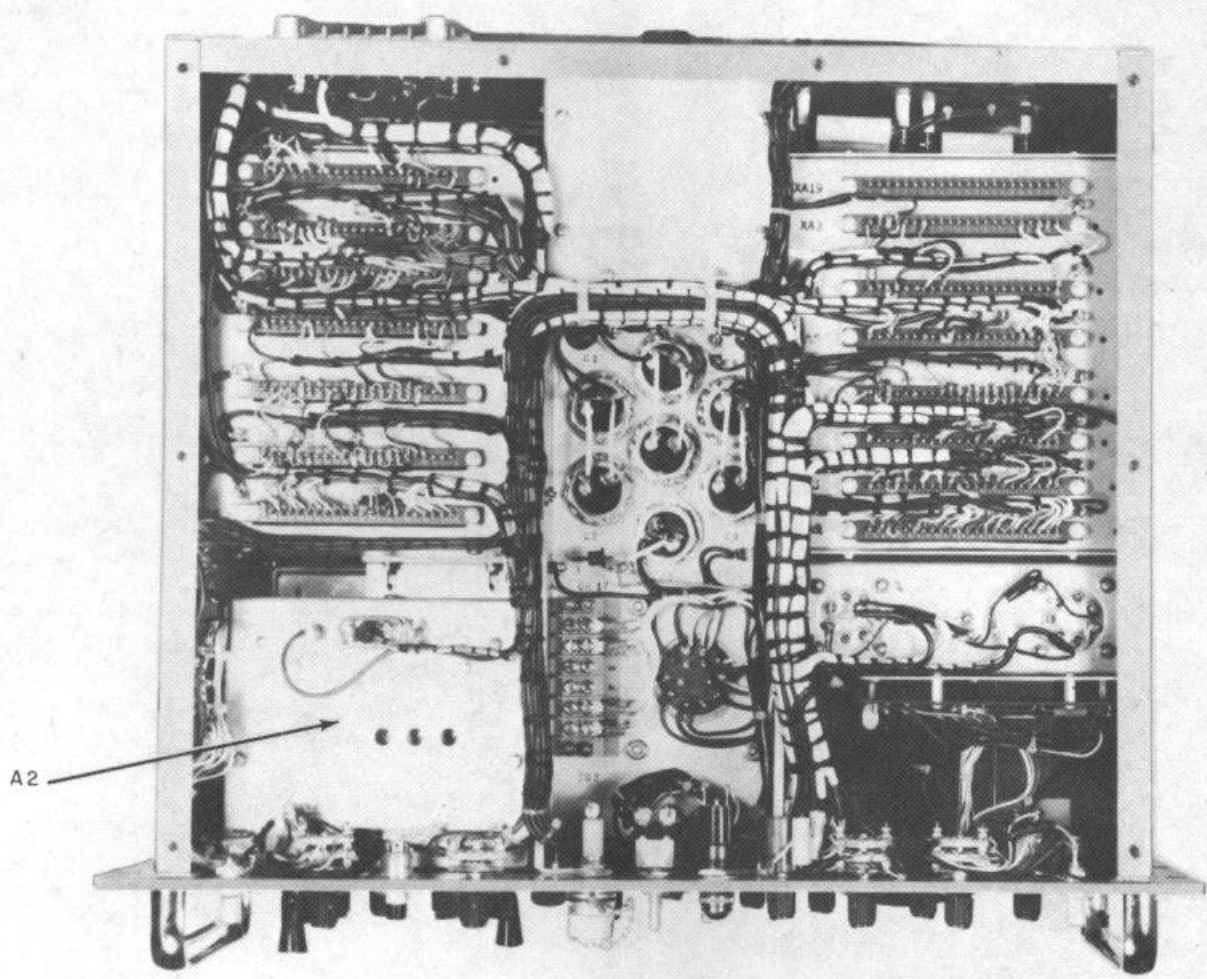

Figure 9-34(1). Location of assemblies (part 1 of 2).



EL 6625-922-15-51 (2)

Figure 9-34(2). Location of assemblies (part 2 of 2).

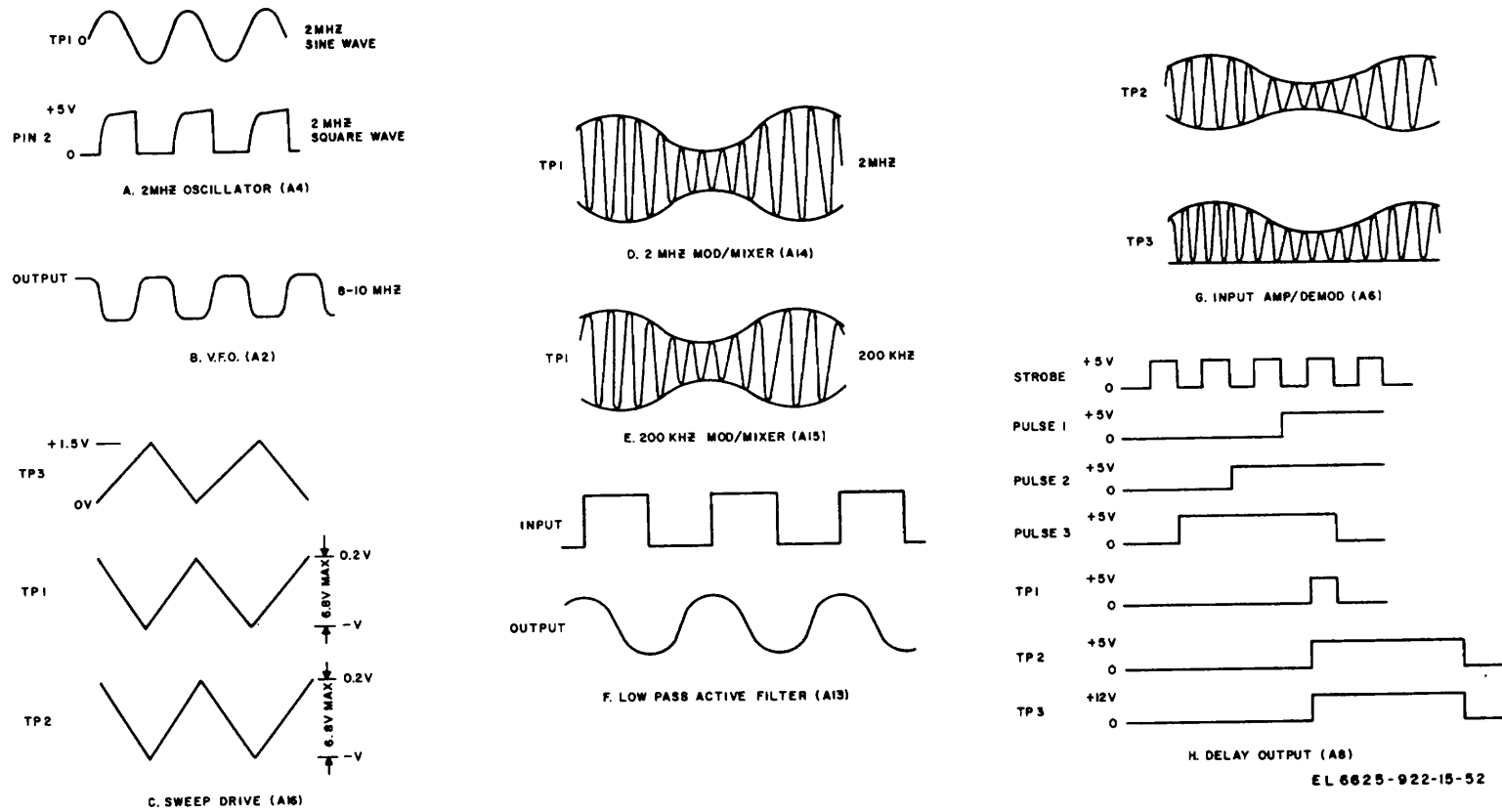

Figure 9-35. Signal waveforms.

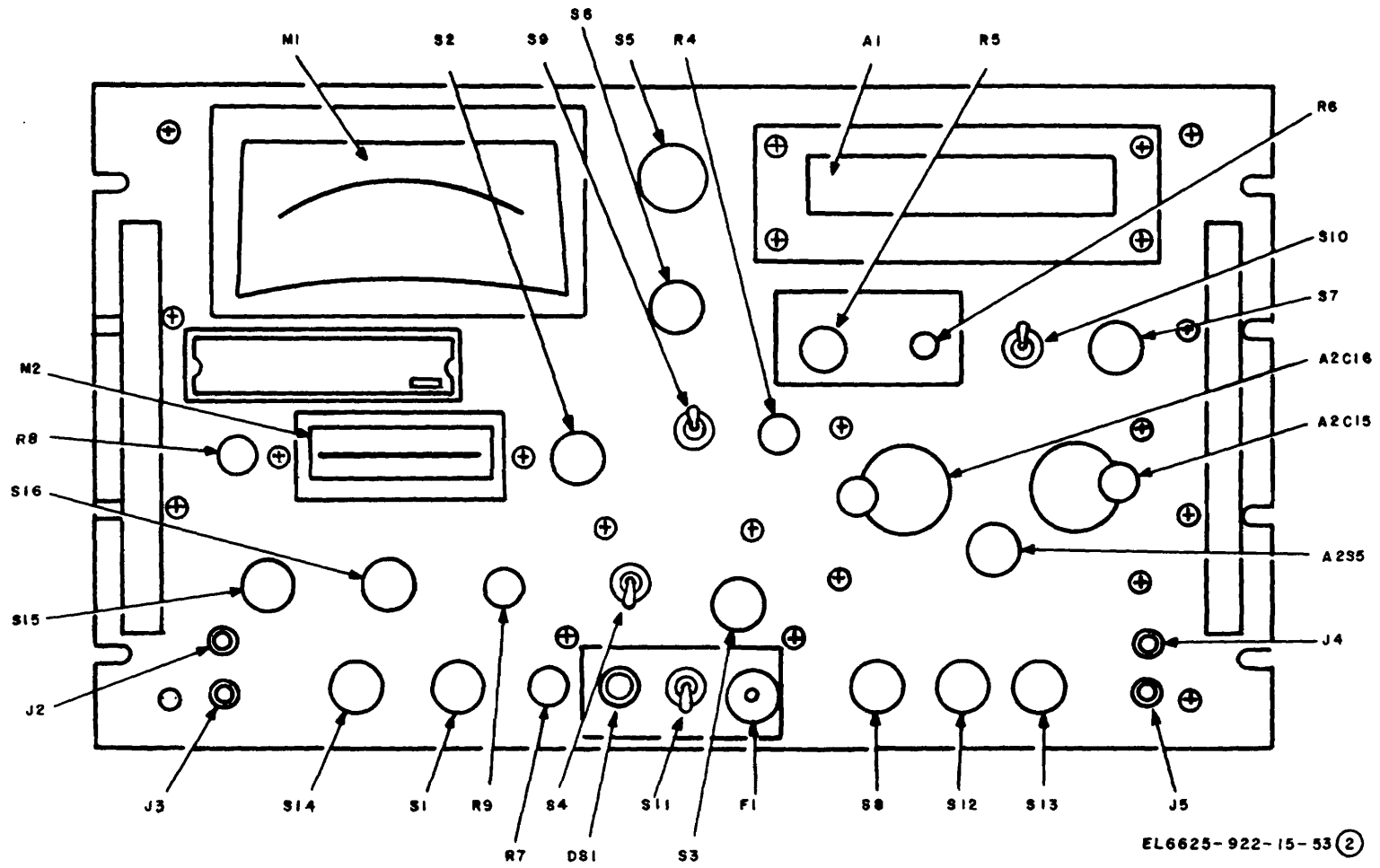
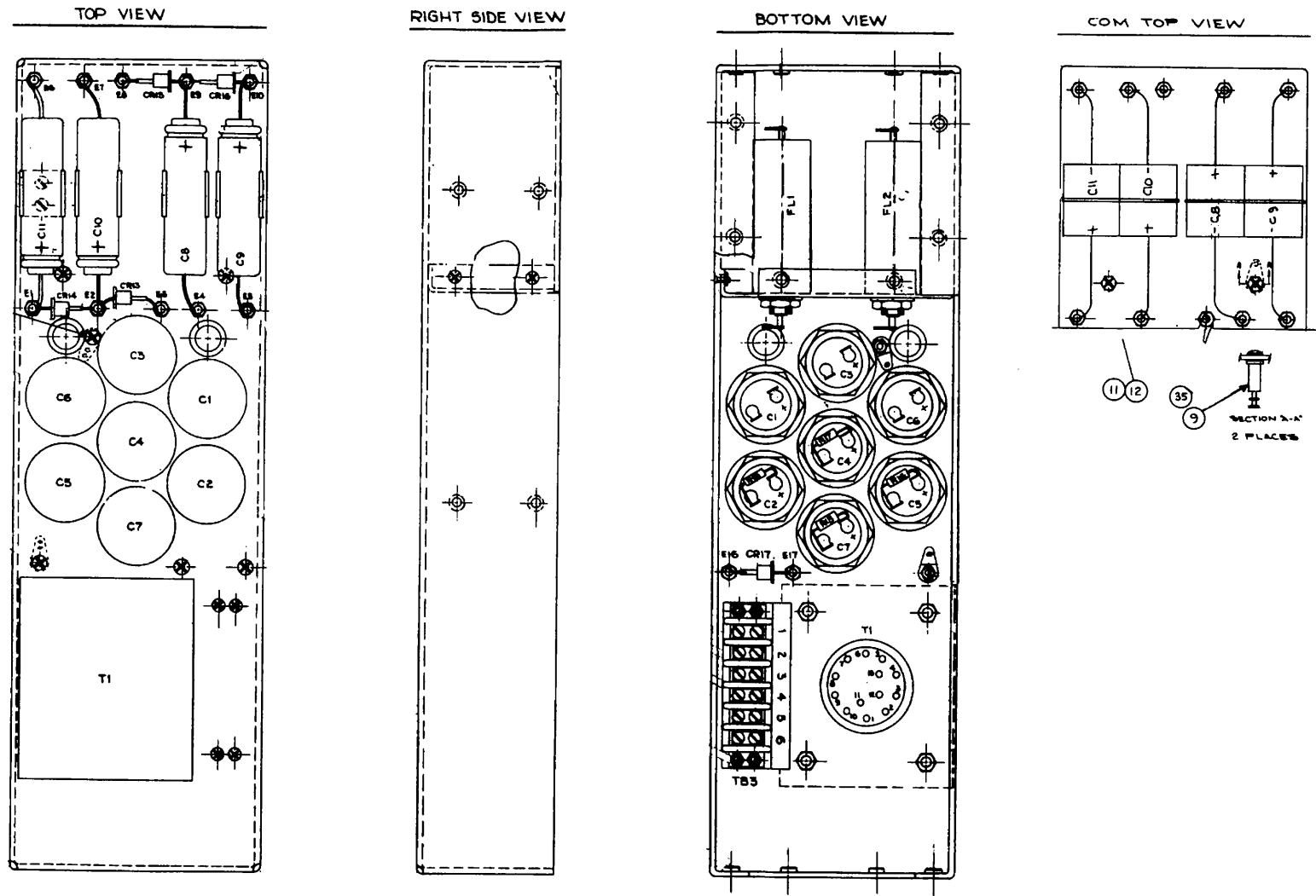
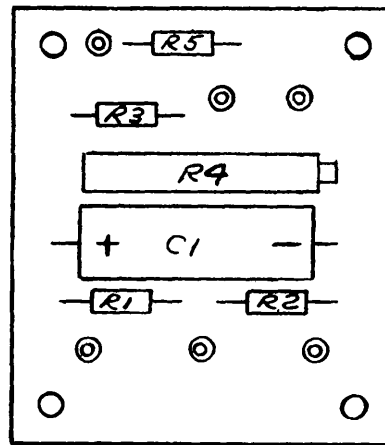

Figure 9-36(2). Assembly drawing (part 2 of 4).



EL 6625-922-15-53 (3)

Figure 9-36(3). Assembly drawing (part 3 of 4).



EL6625-922-15-59

Figure 9-42. Meter modulation adjust (A20), B-4806, location of components

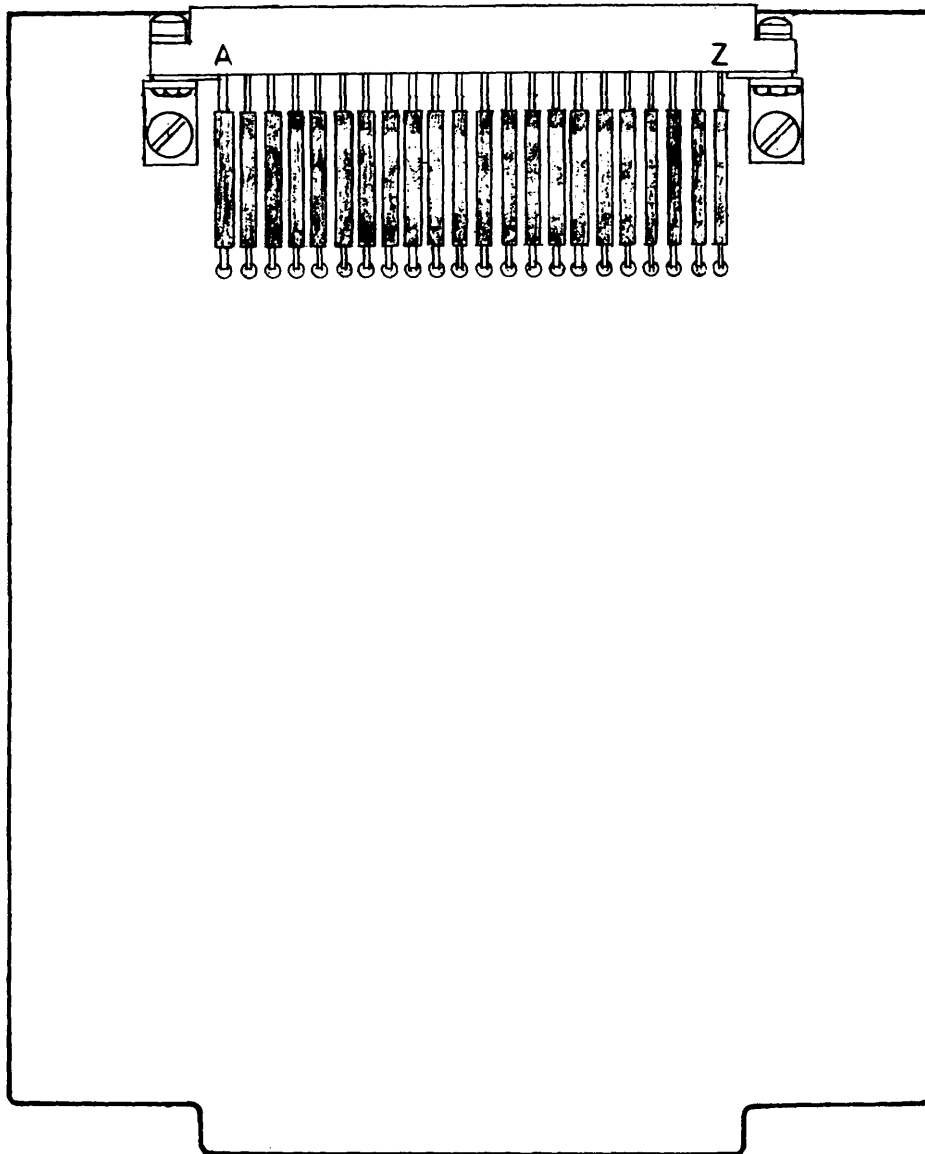

EL6625-922-15-60

Figure 9-43. Extender board assembly (A19), C-4695.

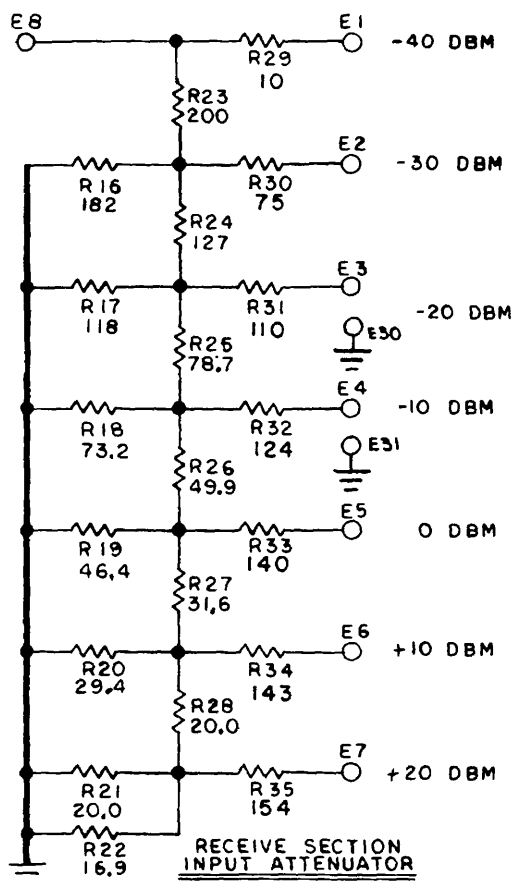
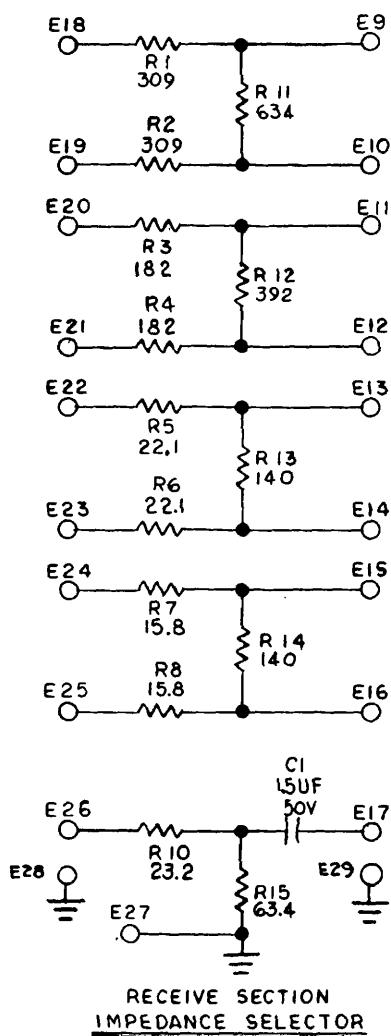

**NOTE:**  
RESISTORS IN INPUT ATTENUATOR  
SECTION ARE IN OHMS  $\frac{1}{4}W, \pm 1\%$  THOSE  
IN IMPEDANCE SELECTOR SECTION  
ARE  $1/8W, \pm 1\%$ .

Figure 9-39. Receive impedance selector and attenuator (A18), C-4714, schematic diagram

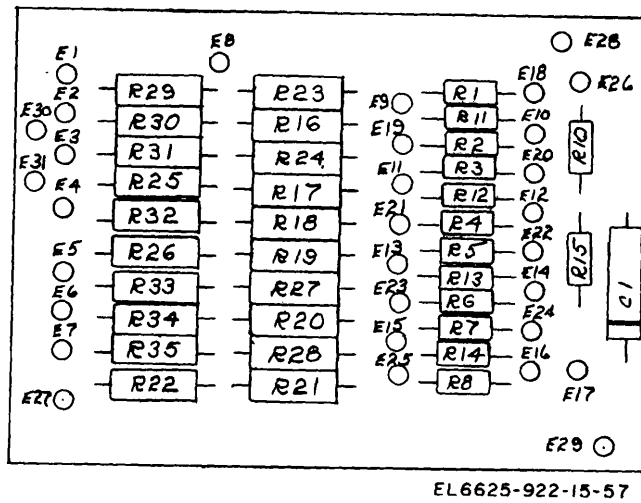

Figure 9-40. Receive impedance selector and attenuator (A18), C-4714, location of components.

NOTE:  
UNLESS OTHERWISE SPECIFIED  
RESISTORS ARE 1/4 W, 5%

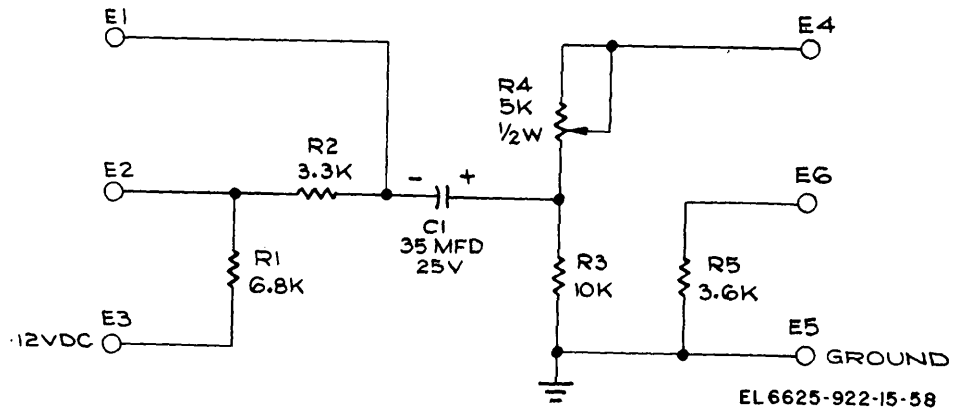
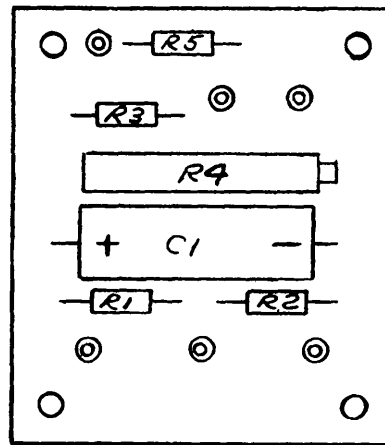

Figure 9-41. Meter modulation adjust (A20), B-4806, Schematic diagram





EL6625-922-15-59

Figure 9-42. Meter modulation adjust (A20), B-4806, location of components

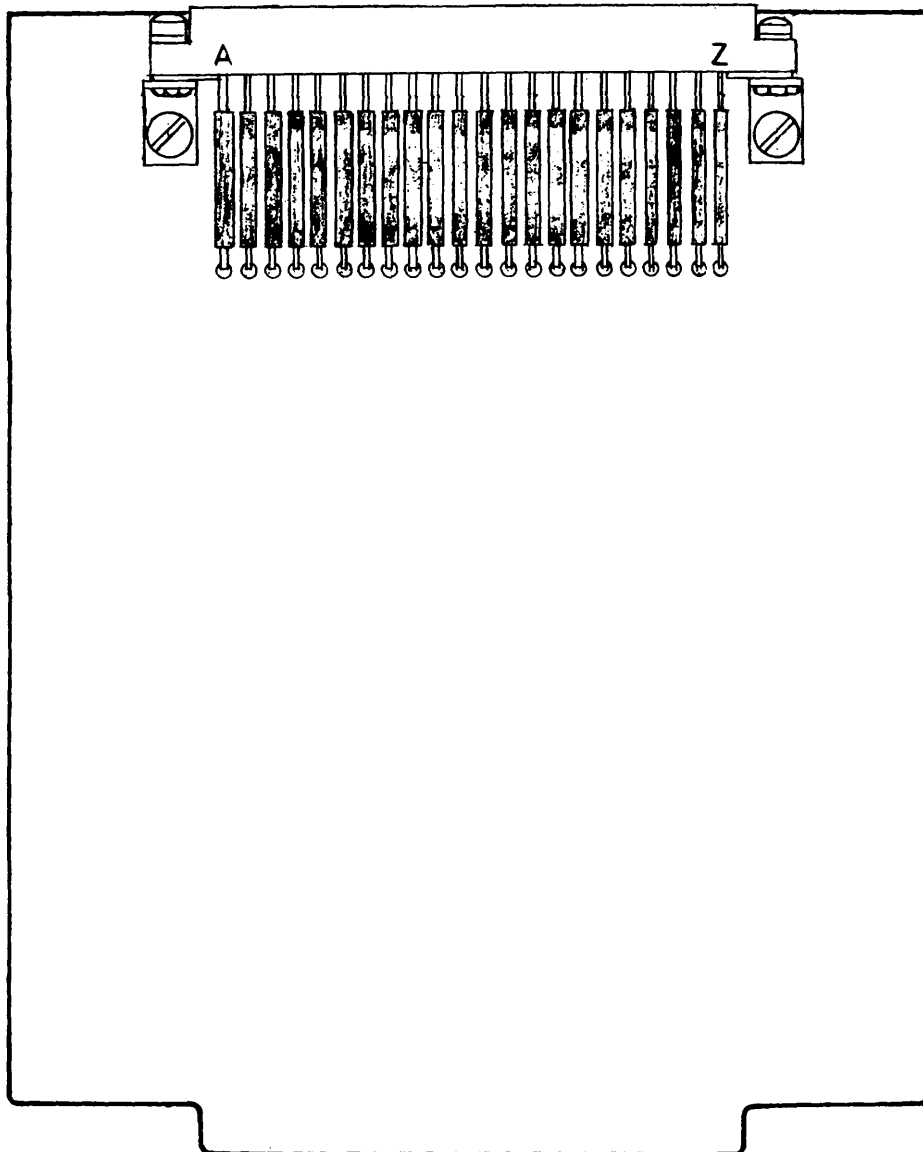

EL6625-922-15-60

Figure 9-48. Extender board assembly (A19), C-4695.

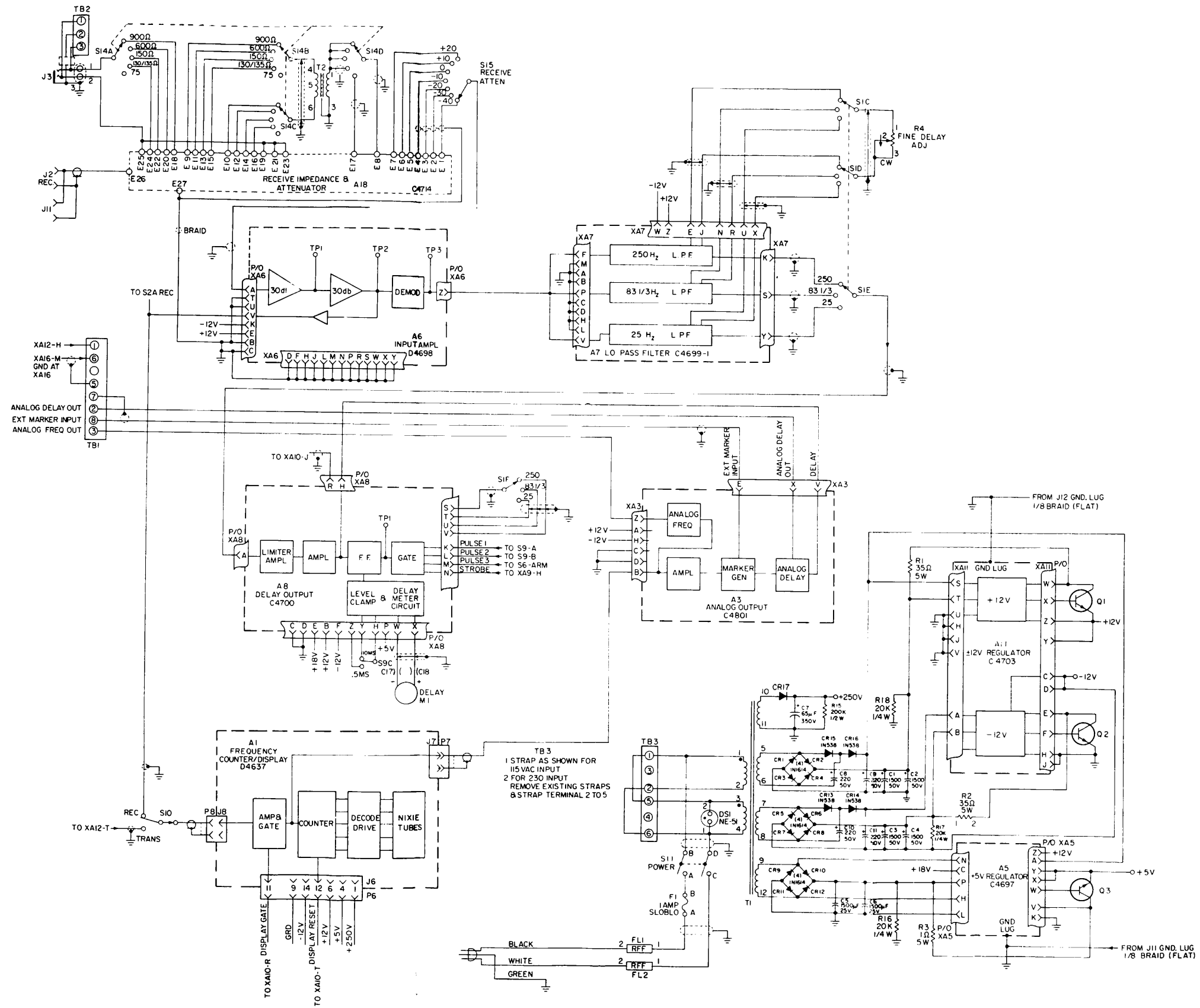

Figure 9-1. Complete schematic diagram (transmit).

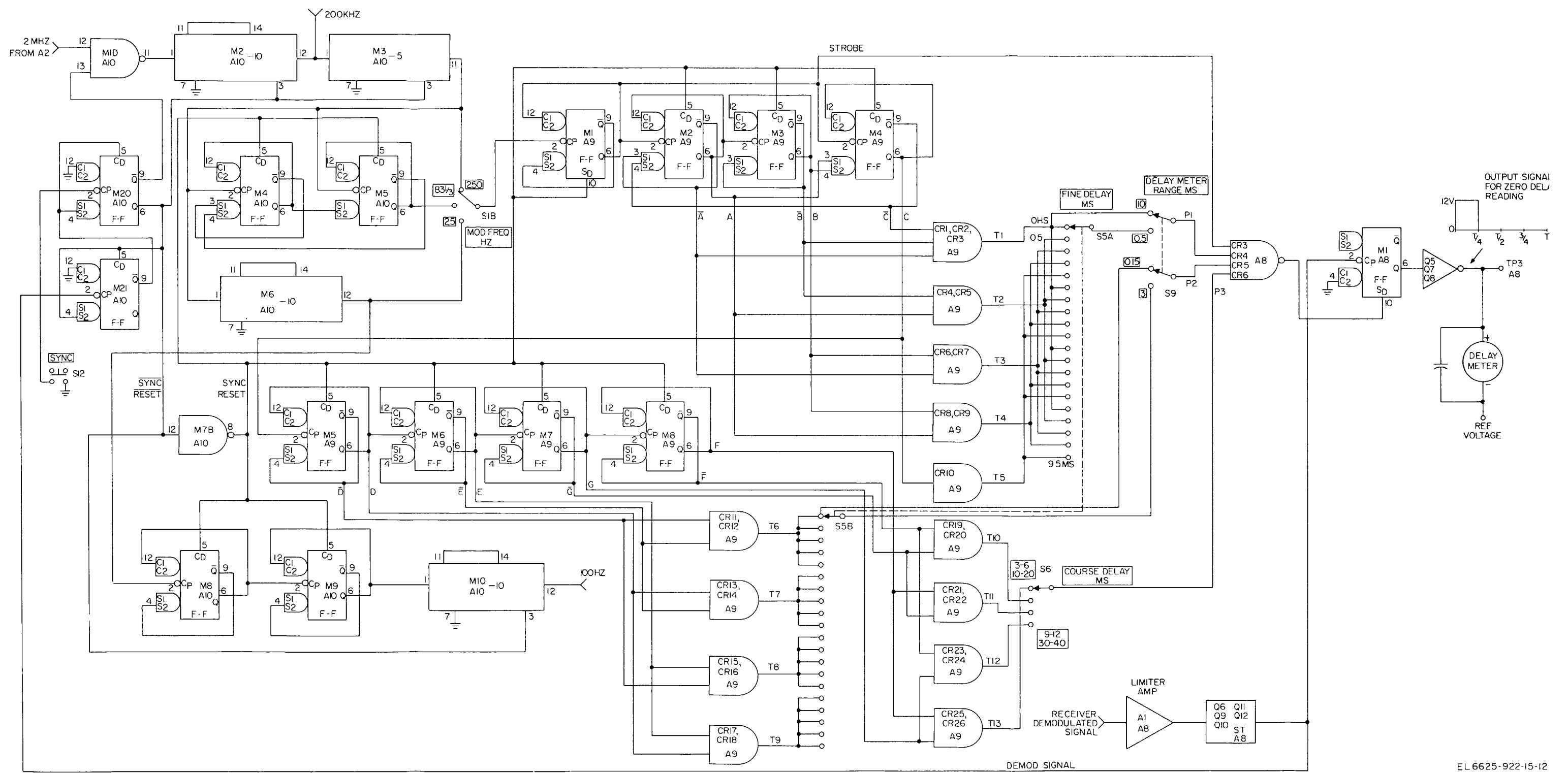

Figure 5-4. Delay and frequency generation logic.

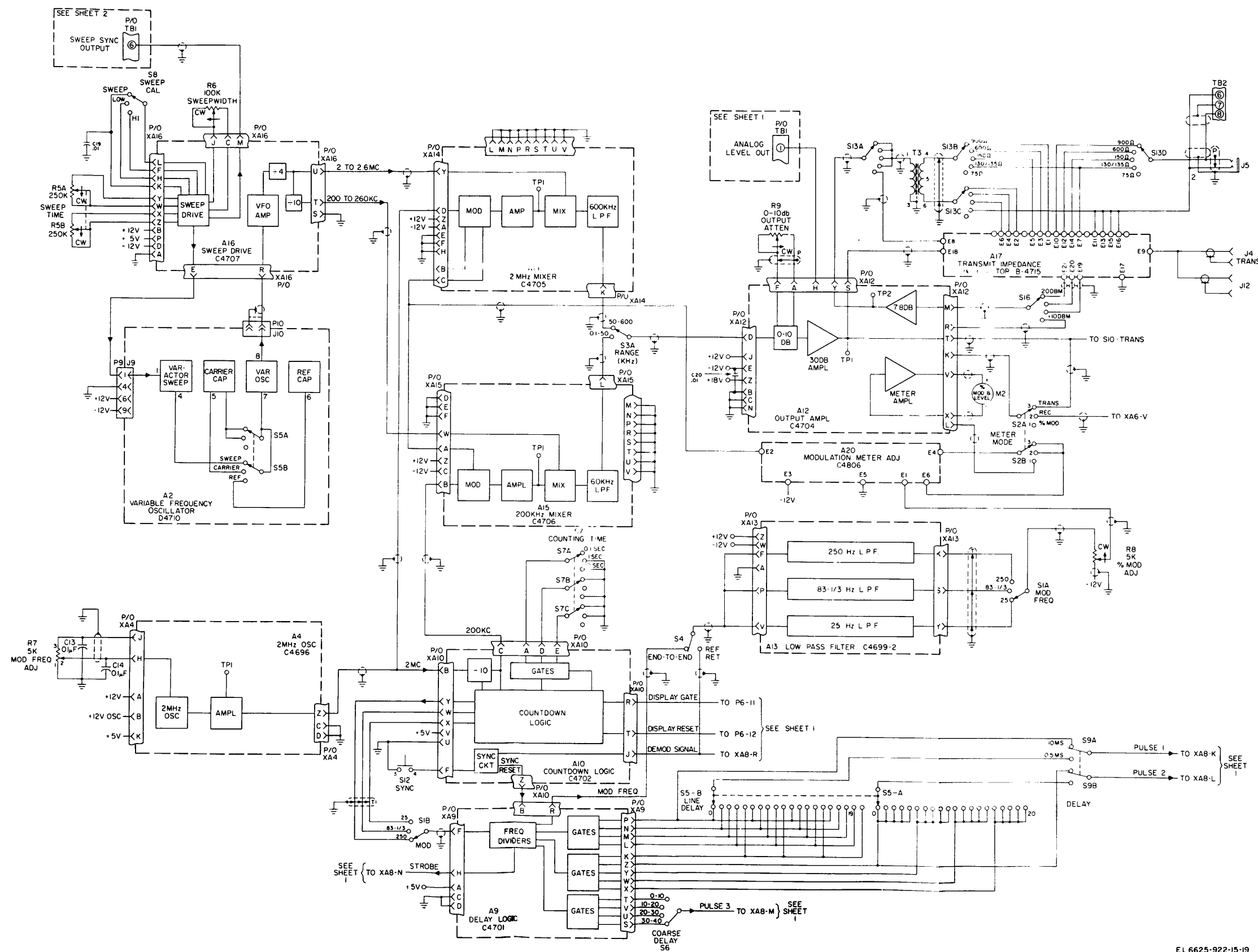
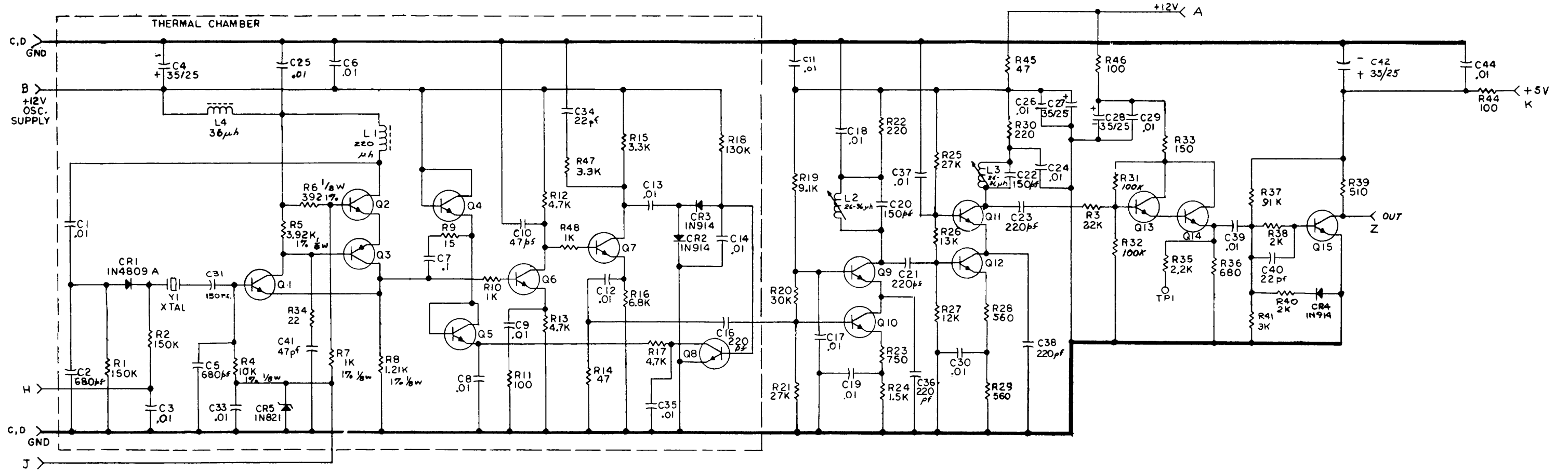

Figure 9-2. Complete schematic diagram (receive).

Figure 9-2.



**NOTES**

- 1 UNLESS OTHERWISE NOTED ALL RESISTORS ARE IN OHMS, 1/4W, ± 5%
- 2 UNLESS OTHERWISE NOTED ALL CAPACITANCES ARE IN MICROFARADS.
- 3 ALL TRANSISTORS ARE 2N3904 EXCEPT Q3 WHICH IS 2N3906.

Figure 9-3. 2-MHz oscillator (A4), C-4696, schematic diagram.

Figure 9-3.

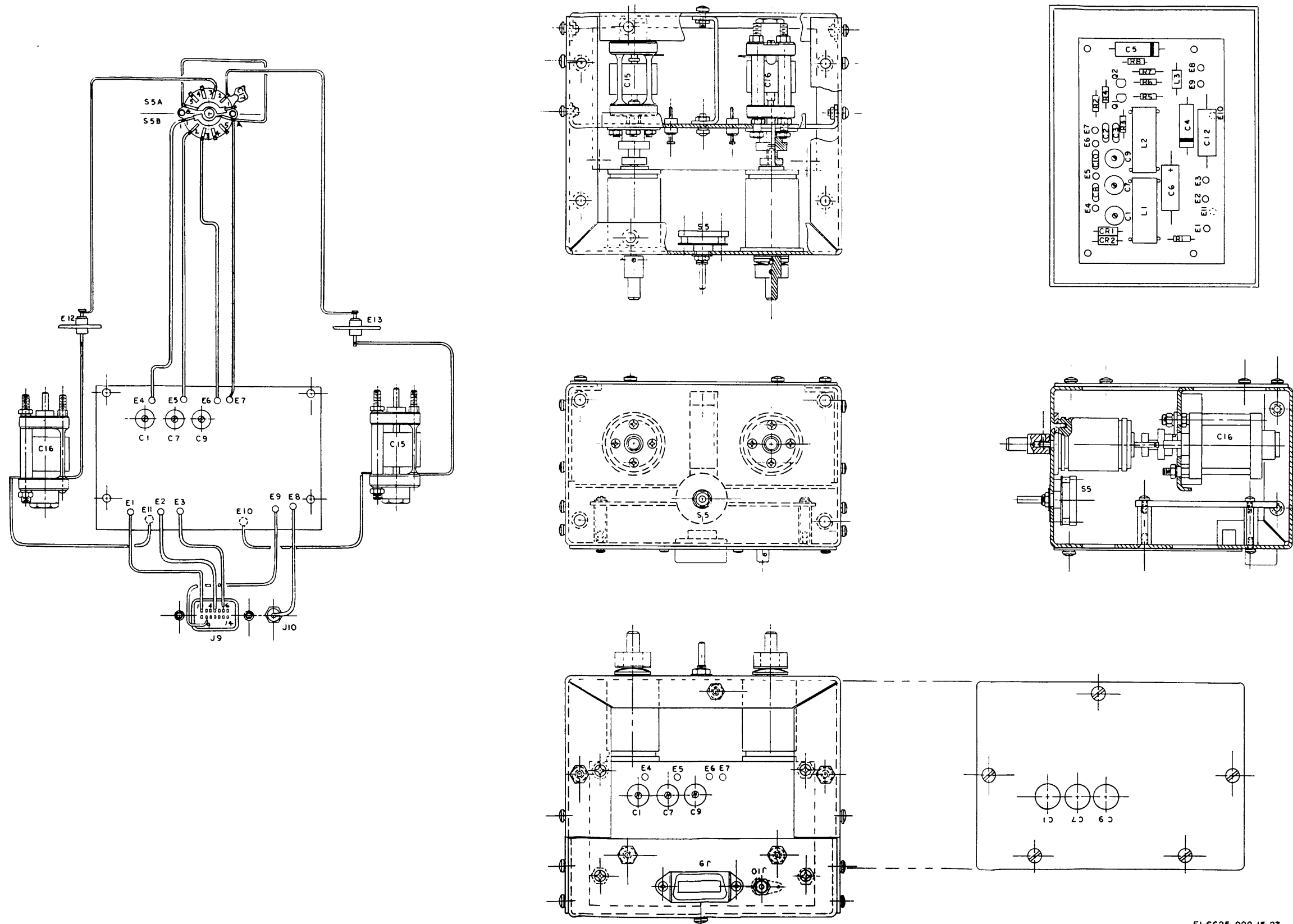
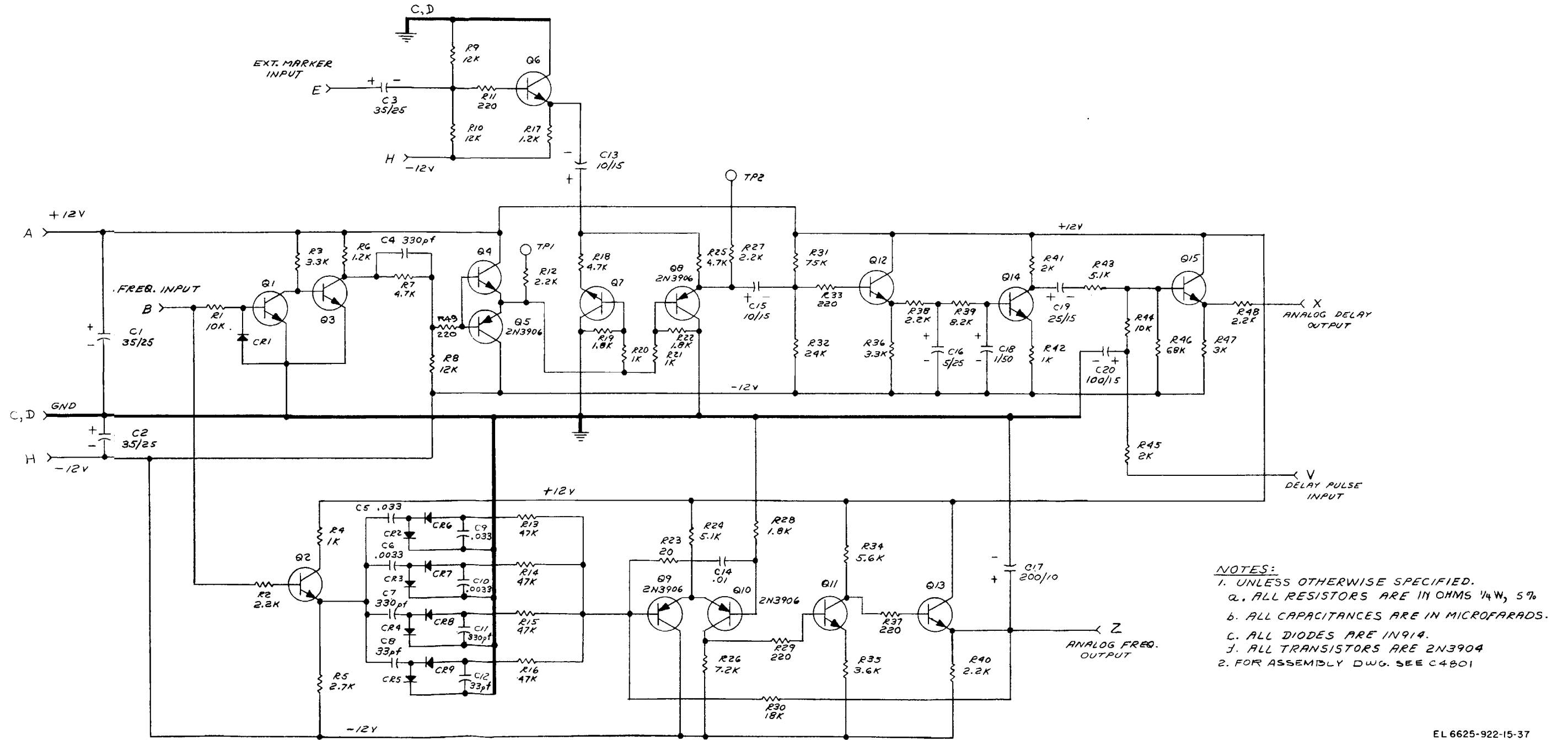

Figure 9-6. Variable-frequency oscillator (A2), D-4710, location of components.

Figure 9-6.

EL 6625-922-15-23



EL 6625-922-15-37

Figure 9-20. Analog output (AS), C-4801, schematic diagram.

Figure 9-20.

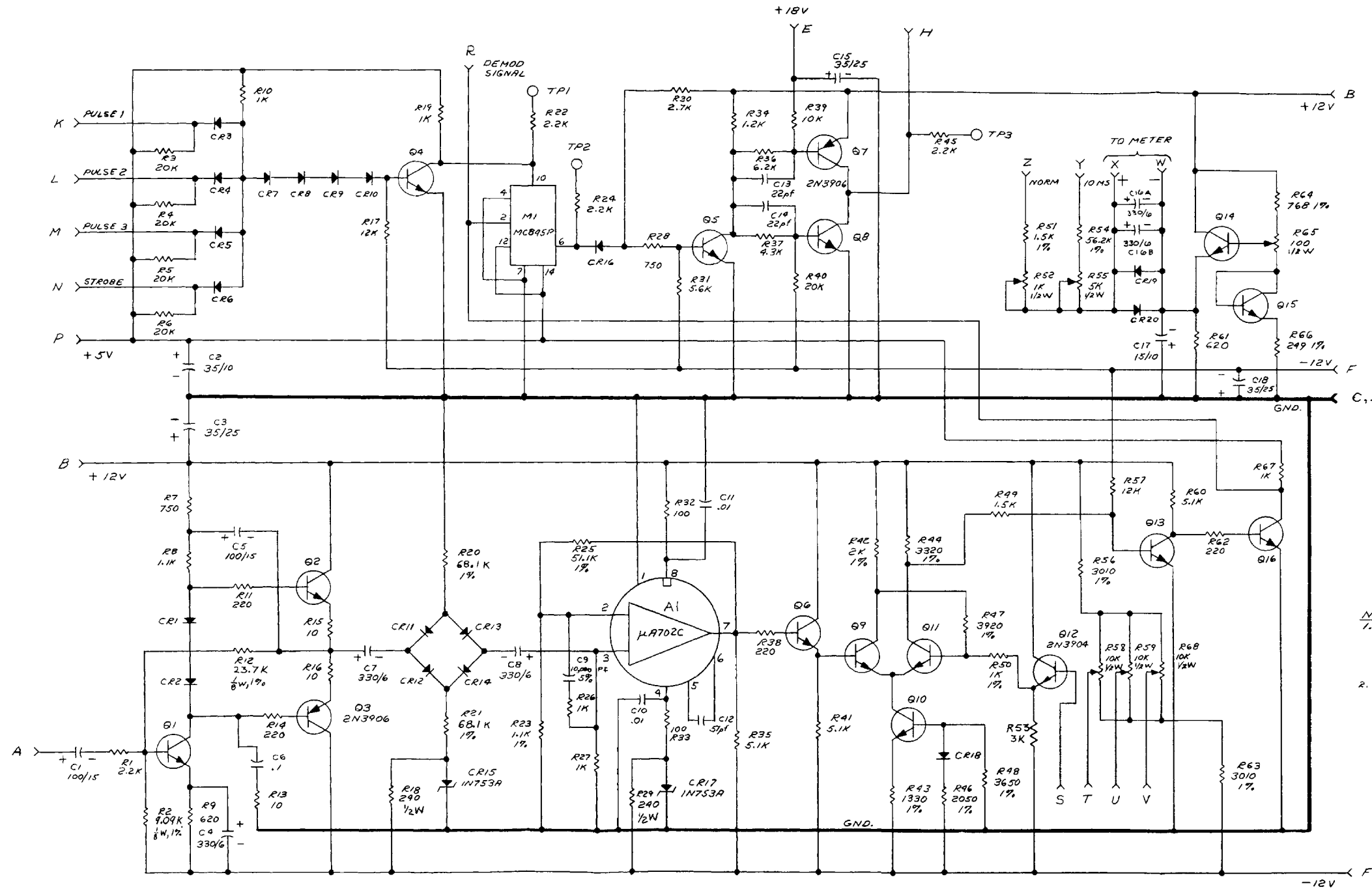

NOTES:  
 1. UNLESS OTHERWISE SPECIFIED:  
 A. ALL RESISTORS ARE IN OHMS 1/4W, 5%  
 B. ALL CAPACITANCES ARE IN MICROFARADS.  
 C. ALL DIODES ARE IN 914.  
 D. ALL TRANSISTORS ARE 2N3904.  
 2. FOR ASSEMBLY DRAWING SEE C4700

EL 6625-922-15-39

PUB NO 7011-6625-223-25  
 IC NO 7-22

Figure 9-22. Delay output (A8), C-4700, schematic diagram.

Figure 9-22.



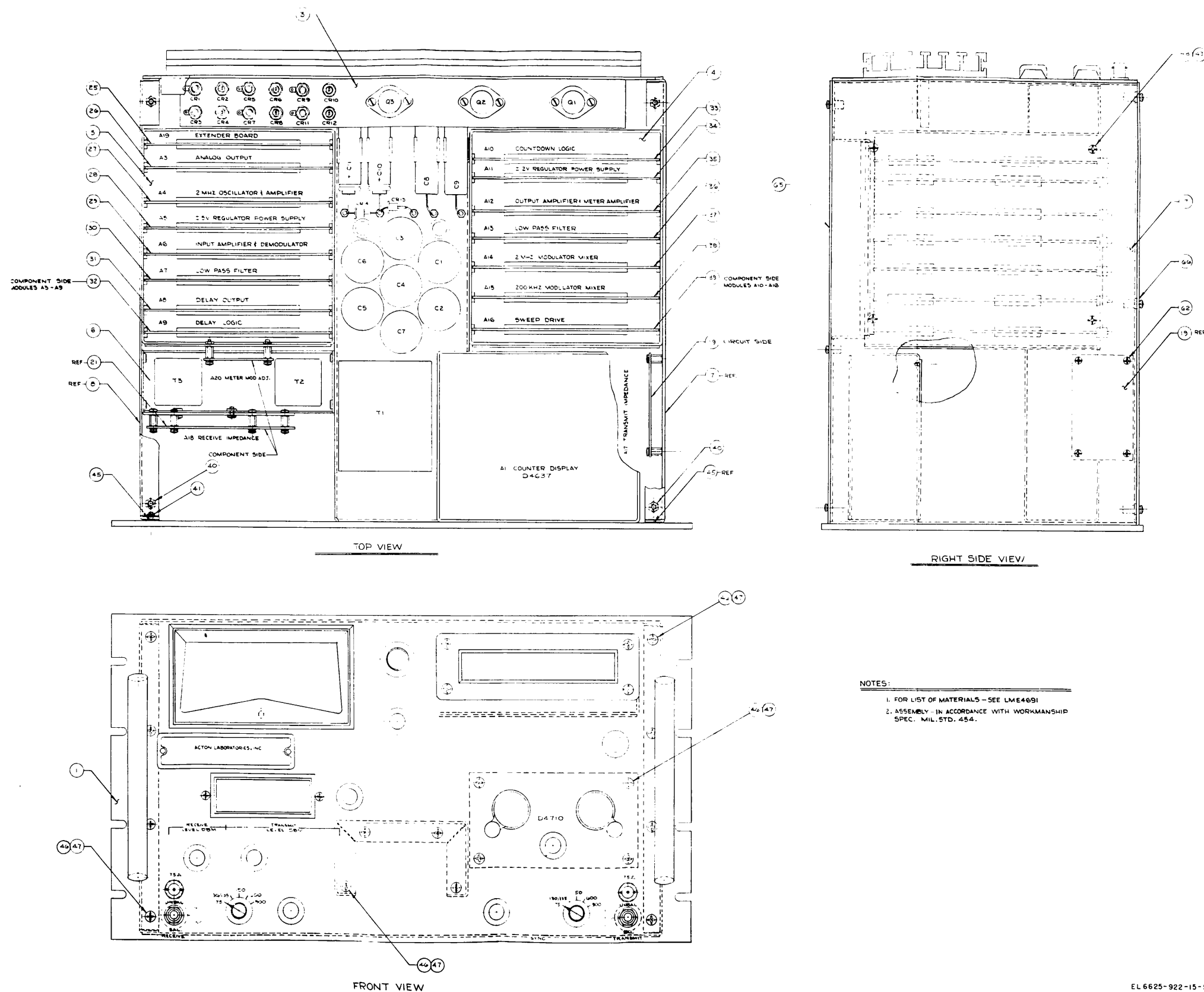

Figure 9-6(1). Assembly drawing (part 1 of 4).

Figure 9-36(1).

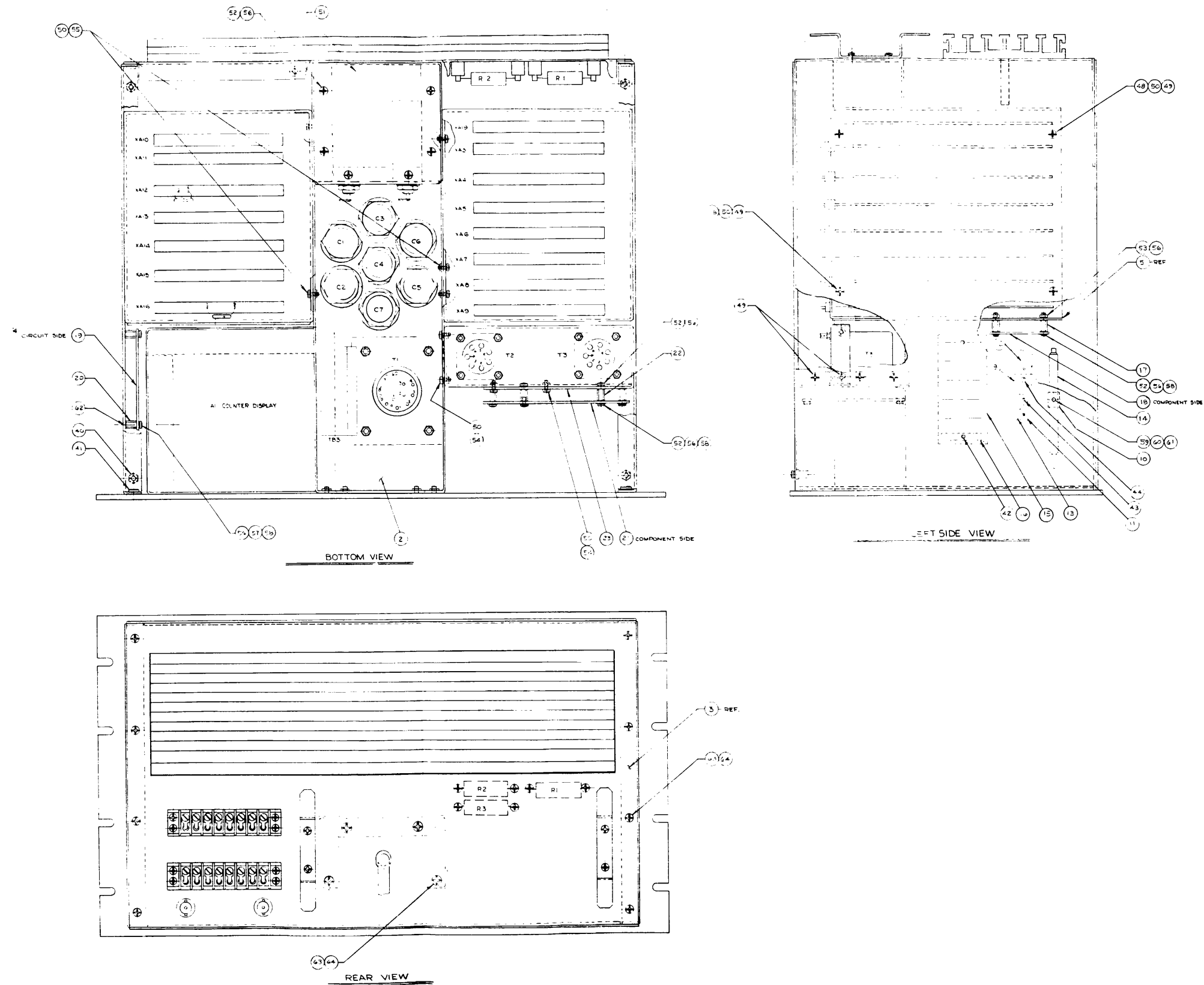



Figure 9-36(4). Assembly drawing (part 4 of 4).

RECOMMENDED CHANGES TO EQUIPMENT TECHNICAL PUBLICATIONS

 <p style="text-align: center;"><i>THEN...JOT DOWN THE DOPE ABOUT IT ON THIS FORM. CAREFULLY TEAR IT OUT, FOLD IT AND DROP IT IN THE MAIL.</i></p>		SOMETHING WRONG WITH PUBLICATION	
		FROM: (PRINT YOUR UNIT'S COMPLETE ADDRESS)	
		DATE SENT	
PUBLICATION NUMBER		PUBLICATION DATE	PUBLICATION TITLE
IN THIS SPACE, TELL WHAT IS WRONG AND WHAT SHOULD BE DONE ABOUT IT.			
BE EXACT PIN-POINT WHERE IT IS			
PAGE NO.	PARA-GRAPH	FIGURE NO.	TABLE NO.
PRINTED NAME, GRADE OR TITLE AND TELEPHONE NUMBER		SIGN HERE	

## The Metric System and Equivalents

### *Linear Measure*

1 centimeter = 10 millimeters = .39 inch  
 1 decimeter = 10 centimeters = 3.94 inches  
 1 meter = 10 decimeters = 39.37 inches  
 1 dekameter = 10 meters = 32.8 feet  
 1 hectometer = 10 dekameters = 328.08 feet  
 1 kilometer = 10 hectometers = 3,280.8 feet

### *Weights*

1 centigram = 10 milligrams = .15 grain  
 1 decigram = 10 centigrams = 1.54 grains  
 1 gram = 10 decigrams = .035 ounce  
 1 decagram = 10 grams = .35 ounce  
 1 hectogram = 10 decagrams = 3.52 ounces  
 1 kilogram = 10 hectograms = 2.2 pounds  
 1 quintal = 100 kilograms = 220.46 pounds  
 1 metric ton = 10 quintals = 1.1 short tons

### *Liquid Measure*

1 centiliter = 10 milliliters = .34 fl. ounce  
 1 deciliter = 10 centiliters = 3.38 fl. ounces  
 1 liter = 10 deciliters = 33.81 fl. ounces  
 1 dekaliter = 10 liters = 2.64 gallons  
 1 hectoliter = 10 dekaliters = 26.42 gallons  
 1 kiloliter = 10 hectoliters = 264.18 gallons

### *Square Measure*

1 sq. centimeter = 100 sq. millimeters = .155 sq. inch  
 1 sq. decimeter = 100 sq. centimeters = 15.5 sq. inches  
 1 sq. meter (centare) = 100 sq. decimeters = 10.76 sq. feet  
 1 sq. dekameter (are) = 100 sq. meters = 1,076.4 sq. feet  
 1 sq. hectometer (hectare) = 100 sq. dekameters = 2.47 acres  
 1 sq. kilometer = 100 sq. hectometers = .386 sq. mile

### *Cubic Measure*

1 cu. centimeter = 1000 cu. millimeters = .06 cu. inch  
 1 cu. decimeter = 1000 cu. centimeters = 61.02 cu. inches  
 1 cu. meter = 1000 cu. decimeters = 35.31 cu. feet

## Approximate Conversion Factors

<i>To change</i>	<i>To</i>	<i>Multiply by</i>	<i>To change</i>	<i>To</i>	<i>Multiply by</i>
inches	centimeters	2.540	ounce-inches	Newton-meters	.007062
feet	meters	.305	centimeters	inches	.394
yards	meters	.914	meters	feet	3.280
miles	kilometers	1.609	meters	yards	1.094
square inches	square centimeters	6.451	kilometers	miles	.621
square feet	square meters	.093	square centimeters	square inches	.155
square yards	square meters	.836	square meters	square feet	10.764
square miles	square kilometers	2.590	square meters	square yards	1.196
acres	square hectometers	.405	square kilometers	square miles	.386
cubic feet	cubic meters	.028	square hectometers	acres	2.471
cubic yards	cubic meters	.765	cubic meters	cubic feet	35.315
fluid ounces	milliliters	29.573	cubic meters	cubic yards	1.308
pints	liters	.473	milliliters	fluid ounces	.034
quarts	liters	.946	liters	pints	2.113
gallons	liters	3.785	liters	quarts	1.057
ounces	grams	28.349	liters	gallons	.264
pounds	kilograms	.454	grams	ounces	.035
short tons	metric tons	.907	kilograms	pounds	2.205
pound-feet	Newton-meters	1.356	metric tons	short tons	1.102
pound-inches	Newton-meters	.11296			

### Temperature (Exact)

°F	Fahrenheit temperature	5/9 (after subtracting 32)	Celsius temperature	°C
----	------------------------	----------------------------	---------------------	----

**PIN: 013605-000**